



westfalia
AUTOMOTIVE



Towbars

Wiring Kits

Cycle Carriers

Roof Racks

Power Springs

2015 Catalogue

Towbars at a glance

RX

- **Maximum user comfort**
- **Invisible once retracted**

The manually retractable system is the latest innovation from Westfalia-Automotive. The towball neck is simply unlocked using the handle.



A40H/V

- **Top quality**
- **Simple to use**
- **Millions sold**

This detachable automatic system – our best-seller – offers optimum convenience and is quite invisible once the towball neck has been removed.



A50H

- **Horizontal system**
- **Quick and reliable**
- **Automatic locking**

To use the towing hitch, the towball neck is inserted horizontally into the receiving lug. It is locked automatically – securely and without rattling!



F 10/20

- **Affordable**
- **Very durable**
- **Ball towbar welded or screwed in place**

The fixed system - simple but will last for years.



ELECTRICAL KITS

- **OEM quality**
- **Reduced installation effort / time-saving mounting**
- **Over 500 different vehicle types in the programme**

A differentiated range offering the right wiring kit for every application.



**SEE REVERSE
FOR KEY**

Towbars at a glance

RX

Thanks to its compact design and special swivel sequence, this towbar is even suitable for vehicles with limited installation space. A convenient socket on the towball neck makes it easy to establish the electrical connections between the vehicle and the trailer/cycle carrier.



A40H/V

It uses three balls that hold the towball neck securely in the receiving lug, without any play or wear. This ensures total safety, yet easy operation and the highest level of comfort.



A50H

To use the towing hitch, the towball neck is inserted horizontally into the receiving lug. It is locked automatically. The towball neck is secured against theft by means of a lock.



F 10/20

The fixed model is our most affordable towbar. This Westfalia-Automotive towbar is distinguished by its fast and precise assembly.



ELECTRICAL KITS

Westfalia-Automotive wiring kits are perfectly matched to the vehicle architecture. The product range extends from wiring kits with relay technology to high-tech CAN bus kits, which are actively connected to the vehicle data bus. With the research and development work at the "Electronics Competence Centre", Westfalia-Automotive is a consistent innovator and the leading supplier of wiring kits in Europe.



About us

A brilliant invention – the towbar

As the inventor of the ball towbar, which has been patented worldwide, Westfalia-Automotive has held a natural claim to leadership in this field since 1932. This stroke of genius is typical of the strategy on which our success has been founded for over 80 years:

- constant innovation
- top quality
- maximum safety
- consistent orientation towards the customer

As a full-line distributor Westfalia-Automotive manufactures more than 1,700 different types of towbar – specifically engineered for each make and model. The product portfolio is rounded off by wiring kits, cycle carriers and accessories. Customers include all major car manufacturers as well as the leading wholesalers on the international aftermarket.

Products build trust

Our products have long enjoyed global recognition and lasting trust among drivers, garages and the automotive industry. They are characterised by the top quality inherent in German standards.

Every user benefits here – consumers from no-compromise safety on the road, garages from easy fitting and use, and industry from the close cooperation and customised products that result. Allowing us to offer all partners what they want – be it better quality of life or improved profitability.

Tested through and through – top marks from users

At our test centre all key resources for product development are concentrated into 3,500 square metres. At the in-house labs testing is based on automotive industry standards. Just-in-time delivery is ensured by the attached logistics centre with its 24-hour service.

There's a good reason why we have been voted Best Brand for towbars by the readers of the magazine "auto motor und sport" seven times running. Such outstanding quality is no coincidence, but thanks to our highly skilled, dedicated employees, continuous research and systematic process orientation.

International presence

International expansion in Europe and overseas has been stepped up to develop the company's position as a traditional player on global markets. Besides the company first founded in the Westphalian town of Rheda-Wiedenbrück and its international sales offices, the corporate group also includes the subsidiaries SIARR (France), Monoflex (Sweden), Westfalia-Automotive Asia-Pacific (New Zealand) and Westfalia-Automotive Australia. Sales offices in all major European markets.



Power springs

At last something stopping you going
“weak at the knees” – Simple and effective

Heavily loaded vehicles perform significantly better under extreme conditions, including emergency manoeuvres at high speeds, when fitted with power springs.

This fact prompted Westfalia-Automotive to develop a range of intelligent power springs. They support the vehicle's original suspension system with additional spring force whenever needed.

Extensive on-road testing shows how vehicles become more manageable even when loaded with an additional 300 kilograms of weight. In extreme situations, this can make all the difference: having an accident or continuing happily on your way.

Power springs are an ideal complement to a towbar from Westfalia-Automotive, creating tremendous synergy when installed together at the garage.

Each spring has been developed for a specific vehicle model. Retrofitting is no problem and can be performed at any garage.



This product
Range you
find on page

304

Improved safety with heavy loads

Better handling and comfort

Vehicles prevented from going “weak at the knees”

Low costs

TÜV-tested (by German Technical Inspection Authority)

WITHOUT POWER SPRINGS

Heavy loads can be too much for the standard suspension system of a vehicle – “bringing it to its knees” so to speak at the rear. The result: longer braking distances, risk of skidding and even possibly fishtailing in curves with crosswinds or during overtaking. This is caused by rough or uneven roads and potholes. All reasons to reinforce your vehicle's original suspension system when driving with heavy loads.

Slalom and obstacle avoidance test with 300 kg load in boot.

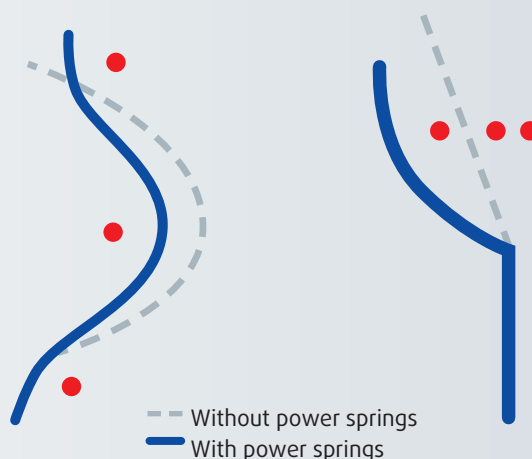

WITH POWER SPRINGS

Power springs from Westfalia-Automotive are designed to be simple and effective. Their extra boost of power is what's needed to keep your vehicle “off its knees”. They provide extra on-road stability and offer better grip for the front tyres to keep braking distances short. You can tow heavy loads more easily while minimising the risk of trailers or caravans fishtailing.

Roof racks

Specially designed for use with commercial vehicles.

Roof racks from Westfalia-Automotive impress with the stability and reliability they offer during the daily routine of the commercial vehicle sector – whether used by roofers, fitters or carpenters.

It goes without saying that they need a simple, vehicle-specific system for fixing loads to the roof. Once the roof rack has been fitted, they have an additional loading area with numerous options. Handling, shipment and storage are facilitated by the modular concept of the roof racks.

These racks are designed for heavy-duty, professional usage. They are individually adapted to each vehicle so as to cater for all wishes of the user. OE quality, real value for money and a wide range of products make roof racks from Westfalia-Automotive true all-rounders.



This product Range you find on page **308**

- Roller and deflector included
- Dimensions according to needs
- Corrosion protection thanks to powder coating
- Improved aerodynamics for optimised consumption
- Use of materials complying with REACH regulations
- Compact warehousing and simple transport due to modular design



Simple installation

Installation time

Installed by 1 person:
45 minutes, plus 10 minutes per intermediate module

Installed by 2 persons:
30 minutes, plus 5 minutes per intermediate module

RX – the retractable towbar



The name “RX System” stands for innovative ideas developed from original equipment for the aftermarket, offering the quality people expect from Westfalia-Automotive. Thanks to its compact design and special swivel sequence, the new retractable system is even suitable for vehicles with limited installation space. In designing the bumper cut-out, Westfalia-Automotive has followed the exact specifications of the vehicle manufacturer.



A convenient socket on the towball neck makes it easy to establish the electrical connections between the vehicle and the trailer / cycle carrier. When the towbar is not in use, it can be swivelled completely out of sight behind the vehicle bumper.

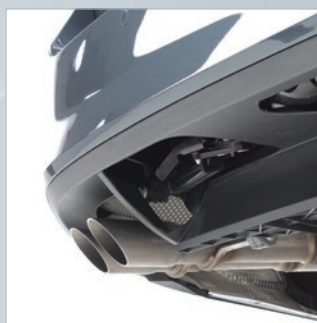

The towbar is unlocked using an easy-access handle positioned behind the bumper. The towball neck is then brought by hand into the final position, with a warning tone indicating the status of the locking mechanism.

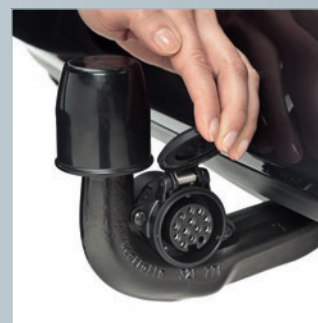

The RX System is distributed as a package with the 13-pin, vehicle-specific wiring kit included. This optimises logistics while providing cost advantages.

KITS – Everything from a single source for a great price

Do you know your kits? A kit is a combination of a towbar and a vehicle-specific wiring kit. Westfalia-Automotive is the only manufacturer to offer over 650 of such kits.

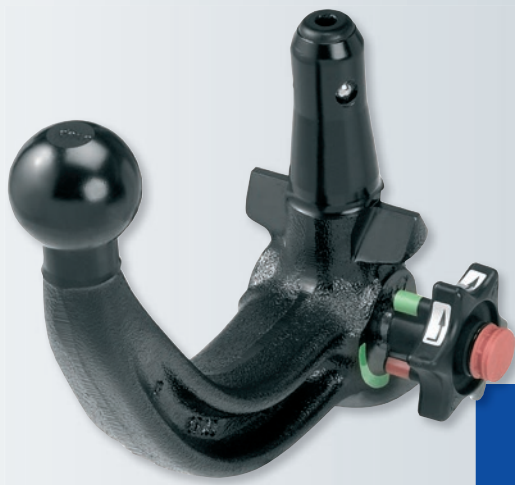

Vehicle-specific wiring kit

- Use of original parts
- Easy assembly
- Extremely reliable
- Complete product portfolio
- Full functionality through connection to onboard electrical system

PLUS

Towbar

- Retractable, detachable or fixed systems
- Reliable
- Original manufacturer quality
- Perfect fit
- User-friendly
- Millions sold
- EC-approved



Similar to illustrations

Kits are shown in our catalogue as follows:

KIT = towbar
+ vehicle-specific wiring kit



Top marks seven times running

Westfalia-Automotive "Best Brand" seven times running! When choosing their "Best Brand", readers of the magazine "auto motor und sport" voted Westfalia-Automotive the winner in the "Towbar" category.

Cycle Carrier BC 60 – one for all (everything)!

Compact and
carefully planned.

The Westfalia-Automotive Cycle Carrier BC 60 impresses right down the line. It stands for a high standard of quality and TÜV/GS-approved safety. It was developed according to the requirements of the automotive industry.



Use of the BC 60 is fully oriented towards the needs of the customer. It is mounted in mere seconds by simply placing it onto the towball, and then fastened with minimum effort. Since the BC 60 is suitable for bicycles with a wheel base of up to 1300 mm and can carry loads up to 60 kg, it is ideal for heavy e-bicycles and Pedelecs. These trendy "Best-Ager" bicycles are very easy to position and fasten – especially when compared to roof racks. And not least, the BC 60 impresses with its "expansion" capabilities due to diverse practical accessories.



After it is used, it can be folded up to save space (58 x 69 x 22 cm) and can be stored in the matching bag in your boot, garage or home.



Double cycle carrier on the towbar

Assembled within seconds with little effort and securely fastened

Tilting for quick access to the boot – even with bicycles!

Folds away to an ultra compact size: 58 x 69 x 22 cm – takes up very little space

Ideal for bicycles with an extremely long wheel base (1300 mm)

60 kg payload: suitable also for heavy electric bicycles

Dear customer,

You now have in your hands the new 2015 Westfalia-Automotive catalogue covering towbars, electrical kits, bicycle racks and spare parts. We have made every effort to incorporate the suggestions and modifications that you have provided us with to further enhance this catalogue. This catalogue provides a wealth of important information and is designed to help you develop and promote your towbar fitting business.

Please note the following:

Fold-out flap on front cover

The legend that corresponds to the columns in this catalogue can be found on the fold-out flap attached to the inside of the front cover of this catalogue. If necessary, you can tear it off and use it as an insert.

KIT = Towbar + 13-pin electrical kit

Our KIT program has been further enhanced with the introduction of additional references. You will now find a KIT for nearly all of our towbar range which is supplied complete with a vehicle specific wiring kit. You can identify these KITs by the last figures of the part number: ... 900013.

Installation times

The specified installation times should only be used as an indication of the time required to carry out an installation. The length of time required to complete this will depend on a number of factors, the condition of the vehicle and/or the skills and experience of the individual carrying out the work. In certain circumstances, the specification of a vehicle may vary significantly, such as when an automatic CD changer has to be removed in order to install the electrical equipment, then the required assembly time may increase considerably. Where possible, always try and ascertain the full specification of the vehicle.

Vehicles with parking sensors:

When mounting permanently attached towbars, the towball may in some instances activate the vehicles rear parking sensors. This problem can be overcome by fitting a detachable towbar where the neck can be removed from the vehicle when not required for towing. Some vehicles do come with cut off switches for the rear parking sensors but you should check with the customer to confirm that this is an acceptable solution.

The following is valid before assembling a towbar and an electrical kit:

Always observe the instructions of the vehicle manufacturer in the operating manual of the vehicle.

Towbars and energy-saving vehicles

Some energy-saving vehicles have not been homologated for towing and therefore have no towing capacity. Always check the VIN plate or the vehicle handbook to verify the towing capacity of the vehicle.

Please visit our website westfalia-automotive.com to find our current product finder, further information and frequently asked questions about our products.

Edition: 02/2015, errors and omissions excepted

Content

Introduction..... 1

Content..... 2

Towbars and electrical kits

A

Alfa Romeo..... 6

Audi 7

B

BMW..... 29

C

Cadillac..... 43

Chevrolet..... 44

Chrysler..... 47

Citroën..... 49

D

Dacia 61

Daihatsu 65

Dodge..... 66

F

Fiat 67

Ford..... 77

H

Honda..... 90

Hummer..... 92

Hyundai 93

I

Isuzu..... 98

Iveco-Magirus..... 99

J

Jeep..... 100

K

Kia 103

L

Lancia..... 109

Land Rover..... 111

Lexus..... 113

M

Mazda..... 114

Mercedes-Benz 119

Mini..... 136

Mitsubishi 137

N

Nissan 139

O

Opel..... 145

P

Peugeot..... 157

Porsche 169

R

Renault..... 170

S

Saab	181
Seat	182
Škoda	188
Smart	196
Ssang Yong	197
Subaru	198
Suzuki	201

T

Toyota	204
--------------	-----

V

Volkswagen	214
Volvo	249

Towing brackets, couplings and special towbars

Mercedes Sprinter / VW-LT	256
Universal towing brackets	258
Towballs and couplings	260
Swap system	262
Special towbars / Couplings for US vehicles....	263

Towbars

Accessories / Spare parts

Accessories for towbars	266
Steps	267
Side caps for towing brackets	268
Spare parts for towbars	269
Spare parts for Monoflex towbars	271
Plug covers for detachable towbars	273

Electrical kits

Accessories / Spare parts

Universal electrical kits	282
Extension kits	283
Control units 12V	284
Relays 12V	288
Adapters and plugs	290
Sockets and seals	291
Accessories for sockets	293
Accessories for electrical kits	295

Cycle carrier BC 60

Cycle carrier and accessories	298
Spare parts	300

Power springs

Product overview power springs	304
--------------------------------------	-----

Roof racks

Product overview roof racks	308
-----------------------------------	-----

Towbars and electrical kits

Key for towbars

	Vehicle
	Year of manufacture
KIT	Towbar + vehicle-specific wiring kit
	Towbar system
	Part No. towbar
	Phase-out model
	Visible cut-out
	Invisible cut-out
	Installation time
	Assembly weight
	D value kN
	Vertical load
	Towed load

A20		A40V		A40H		A50	
detachable nut system		detachable automatic system vertical		detachable automatic system horizontal		detachable small automatic	

RX		MFII		AHII	
retractable		detachable manual system horizontal		detachable automatic system vertical	





















F10		F20		F30		F40	
fixed welded design		fixed screwed design		towing bracket for ball plate (2 screws)		towing bracket for ball plate (4 screws)	





Key for wiring kits

	Phase-out model
	Additional information for wiring kits
	S Wiring kit vehicle-specific No. ...1.7 = 7 pins
	-- Wiring kit universal No. ...1.3 = 13 pins
	C2 Indicator monitoring C2 indicator light
	A Indicator monitoring acoustic
	CAN Indicator monitoring CAN
	FRE Indicator monitoring blink frequency
	C Coding/activation necessary
	C1 Possible without coding -> C2 via buzzer
	-- Coding/activation not necessary
	E Parking aid shut-off
	E1 Parking aid shut-off (universal without preliminary set-up)
	E2 Parking aid shut-off (button on dashboard)
	-- No parking aid shut-off
	D Permanent plus included
	D1 Permanent plus optional (extension kit 300027300113)
	-- No Permanent plus
	L Charging cable included
	L1 Charging cable optional (extension kit 300028300113)
	-- No charging cable
	V Power connection front
	H Power connection rear
	Installation time
	R Right hand drive
R/L/B	L Left hand drive
	B Both











		KIT																								R/L/B
--	--	------------	--	--	--	--	--	--	--	--	--	--	--	--	--	--	--	--	--	--	--	--	--	--	--	--------------











Alfa Romeo

Alfa 156 Saloon & Sportwagon inc. facelift 07/03-	11/97-		306 220 600 001	→		>150	26.5	8.7	90	1600		306 189 300 113	→		S	FRE	--	E	D1	L1	V	120	L
Alfa 156 Saloon & Sportwagon exc. GTA - 250 HP	11/97-07/03		306 219 600 001	→		>150	25.6	8.7	90	1600		306 189 300 113	→		S	FRE	--	E	D1	L1	V	120	L
Alfa 159 Saloon exc. GTA - 250 HP	09/06-		306 355 600 001			120	24.0	9.9	100	1800		306 220 300 113			S	FRE	--	E	D	L1	H	90	B
			306 356 600 001			120	25.0	9.9	100	1800						S	FRE	--	E	D	L1	H	90
		KIT		306 356 900 113			120	27.0	9.9	100	1800		included in the KIT			S	FRE	--	E	D	L1	H	90
Alfa 159 Sportwagon	03/06-		306 355 600 001			120	24.0	9.9	100	1800		306 220 300 113			S	FRE	--	E	D	L1	H	90	B
			306 356 600 001			120	25.0	9.9	100	1800						S	FRE	--	E	D	L1	H	90
		KIT		306 356 900 113			120	27.0	9.9	100	1800		included in the KIT			S	FRE	--	E	D	L1	H	90
Alfa Giulietta	04/10-		306 372 600 001			90	25.0	8.3	90	1500		306 371 300 113			S	FRE	--	E	D1	L1	V	105	B
Alfa Mito	09/08-		306 375 600 001			90	19.0	6.7	75	1100		306 606 300 113			S	FRE	--	E	D1	L1	V	105	B
			306 374 600 001			90	19.0	6.7	75	1100						S	FRE	--	E	D1	L1	V	105



Audi A1	08/10-		317 085 600 001		40	14.5	7.2	86	1200	305 329 300 107	with preliminary setup	S	CAN	C	E	--	--	H		B
										305 329 300 113	with preliminary setup	S	CAN	C	E	D	L1	H		B
										305 330 300 001	extension kit for vehicles without black support for fuse box on the passenger side	S				D1		V	60	B
										305 330 300 107	without preliminary setup	S	CAN	C	E	--	--	V		L
										305 330 300 113	without preliminary setup	S	CAN	C	E	D	L	V		L
										321 600 300 153	without preliminary setup	S	CAN	C	E	D	L1	V	105	R
Audi A1 Please order separately Spoiler and cover for bumper cutout at Audi dealer's.	08/10-		317 086 600 001		40	14.5	7.2	86	1200	305 329 300 107	with preliminary setup	S	CAN	C	E	--	--	H		B
										305 329 300 113	with preliminary setup	S	CAN	C	E	D	L1	H		B
										305 330 300 001	extension kit for vehicles without black support for fuse box on the passenger side	S				D1		V	60	B
										305 330 300 107	without preliminary setup	S	CAN	C	E	--	--	V		L
										305 330 300 113	without preliminary setup	S	CAN	C	E	D	L	V		L
										321 600 300 153	without preliminary setup	S	CAN	C	E	D	L1	V	105	R











Audi

Audi A1 Sportback	02/12-		317 085 600 001		40	14.5	7.2	86	1200	305 329 300 107	with preliminary setup	S	CAN	C	E	--	--	H		B	
										305 329 300 113	with preliminary setup	S	CAN	C	E	D	L1	H		B	
										305 330 300 001	extension kit for vehicles without black support for fuse box on the passenger side	S				D1		V	60	B	
										305 330 300 107	without preliminary setup	S	CAN	C	E	--	--	V		L	
										305 330 300 113	without preliminary setup	S	CAN	C	E	D	L	V		L	
										321 600 300 153	without preliminary setup	S	CAN	C	E	D	L1	V	105	R	
Audi A1 Sportback For optimal fit, order spoiler and cover at Audi dealers.	02/12-		317 086 600 001		40	14.5	7.2	86	1200	305 329 300 107	with preliminary setup	S	CAN	C	E	--	--	H		B	
										305 329 300 113	with preliminary setup	S	CAN	C	E	D	L1	H		B	
										305 330 300 001	extension kit for vehicles without black support for fuse box on the passenger side	S				D1		V	60	B	
										305 330 300 107	without preliminary setup	S	CAN	C	E	--	--	V		L	
										305 330 300 113	without preliminary setup	S	CAN	C	E	D	L	V		L	
										321 600 300 153	without preliminary setup	S	CAN	C	E	D	L1	V	105	R	
Audi A3 exc. Quattro + S3 Please order additionally seal for frame to prevent exhaust leaking into the vehicle, order no. 900002504014.	09/96-05/03		305 222 600 001		90	17.5	8.9	75	1650	305 160 300 173	additional kit for checkcontrol (Please order additionally)	S	--	--	E1	--	--	V	45	L	
										305 223 300 107	305 223 300 113	S	FRE	--	E	--	--	V	60	L	
												S	FRE	--	E	D1	L1	V	60	L	
		KIT		305 391 900 113		120	19.5	8.9	75	1650	305 160 300 173	additional kit for checkcontrol (Please order additionally)	S	--	--	E1	--	--	V	45	L
											KIT		305 392 900 113		120	18.8	8.9	75	1650	included in the KIT	S



Audi A3 Quattro + S3	09/96-05/03			305 277 600 001			120	17.0	8.9	75	1650		305 160 300 173		additional kit for checkcontrol (Please order additionally)	S	--	--	E1	--	--	V	45	L
													305 223 300 107			S	FRE	--	E	--	--	V	60	L
													305 223 300 113			S	FRE	--	E	D1	L1	V	60	L
	KIT			305 393 900 113			120	19.0	8.9	75	1650		305 160 300 173		additional kit for checkcontrol (Please order additionally)	S	--	--	E1	--	--	V	45	L
												included in the KIT			S	FRE	--	E	D1	L1	V	60	L	
Audi A3 Convertible models S3 04/08-: Please check if the vehicle is allowed for towing trailers by the car manufacturer.	04/08-			321 865 600 001			60	17.0	9.4	100	1800		305 256 300 107			S	CAN	C	E	--	--	V	120	B
													305 256 300 113			S	CAN	C	E	D	--	V	120	B
KIT			305 389 900 113			60	19.0	9.4	100	1700		included in the KIT			S	CAN	C	E	D	--	V	120	B	
Audi A3 Convertible inc. S-Line models S3 04/08-: Please check if the vehicle is allowed for towing trailers by the car manufacturer. For optimal fit, order spoiler and cover at Audi dealer.	04/08-			321 885 600 001			60	17.0	9.4	100	1800		305 256 300 113			S	CAN	C	E	D	--	V	120	B
		KIT			305 390 900 113			60	19.0	9.4	100	1700		included in the KIT			S	CAN	C	E	D	--	V	120















Audi

Audi A3 Convertible Please order spoiler inc. cover for bumper cutout at Audi-dealers.	03/14-		317 132 600 001		60	19.0	10.3	80	2000	305 403 300 107	-06/14 with preliminary setup	S	CAN	C	E	--	--	H	45	B
										305 403 300 113	-06/14 with preliminary setup	S	CAN	C	E	--	--	H	45	B
										305 406 300 107	-06/14 without preliminary setup	S	CAN	C	E	--	--	V	150	B
										305 406 300 113	-06/14 without preliminary setup	S	CAN	C	E	D	L1	V	150	B
										305 407 300 107	06/14- with preliminary setup	S	CAN	C	E	--	--	H		B
										305 407 300 113	06/14- with preliminary setup	S	CAN	C	E	D	L	H		B
										305 408 300 107	06/14- without preliminary setup	S	CAN	C	E	--	--	V		B
										305 408 300 113	06/14- without preliminary setup	S	CAN	C	E	D	L	V		B







Audi A3 Convertible	03/14-		317 131 600 001		60	19.0	10.3	80	2000	305 403 300 107	-06/14 with preliminary setup	S	CAN	C	E	--	--	H	45	B	
										305 403 300 113	-06/14 with preliminary setup	S	CAN	C	E	--	--	H	45	B	
										305 406 300 107	-06/14 without preliminary setup	S	CAN	C	E	--	--	V	150	B	
										305 406 300 113	-06/14 without preliminary setup	S	CAN	C	E	D	L1	V	150	B	
										305 407 300 107	06/14- with preliminary setup	S	CAN	C	E	--	--	H		B	
										305 407 300 113	06/14- with preliminary setup	S	CAN	C	E	D	L	H		B	
										305 408 300 107	06/14- without preliminary setup	S	CAN	C	E	--	--	V		B	
										305 408 300 113	06/14- without preliminary setup	S	CAN	C	E	D	L	V		B	
Audi A3 Convertible Please order spoiler inc. cover for bumper cutout at Audi-dealers.	03/14-06/14	KIT		317 132 900 113		60	21.0	10.3	80	2000	included in the KIT	-06/14 without preliminary setup	S	CAN	C	E	D	L1	V	150	B
Audi A3 Convertible	03/14-06/14	KIT		317 131 900 113		60	21.0	10.3	85	2000	included in the KIT	-06/14 without preliminary setup	S	CAN	C	E	D	L1	V	150	B
Audi A3 Convertible Please order spoiler inc. cover for bumper cutout at Audi-dealers.	06/14-	KIT		305 409 900 113		60	21.0	10.3	85	2000	included in the KIT	06/14- without preliminary setup	S	CAN	C	E	D	L	V		B
Audi A3 Convertible	06/14-	KIT		305 408 900 113		60	19.0	10.3	85	2000	included in the KIT	06/14- without preliminary setup	S	CAN	C	E	D	L	V		B













Audi

Audi A3 Saloon	09/13-		317 131 600 001		60	19.0	10.3	80	2000	305 403 300 107	-06/14 with preliminary setup	S	CAN	C	E	--	--	H	45	B
										305 403 300 113	-06/14 with preliminary setup	S	CAN	C	E	--	--	H	45	B
										305 406 300 107	-06/14 without preliminary setup	S	CAN	C	E	--	--	V	150	B
										305 406 300 113	-06/14 without preliminary setup	S	CAN	C	E	D	L1	V	150	B
										305 407 300 107	06/14- with preliminary setup	S	CAN	C	E	--	--	H		B
										305 407 300 113	06/14- with preliminary setup	S	CAN	C	E	D	L	H		B
										305 408 300 107	06/14- without preliminary setup	S	CAN	C	E	--	--	V		B
										305 408 300 113	06/14- without preliminary setup	S	CAN	C	E	D	L	V		B











Audi A3 Saloon Please order spoiler inc. cover for bumper cutout at Audi-dealers.	09/13-			317 132 600 001		60	19.0	10.3	80	2000		305 403 300 107	-06/14 with preliminary setup	S	CAN	C	E	--	--	H	45	B
												305 403 300 113	-06/14 with preliminary setup	S	CAN	C	E	--	--	H	45	B
												305 406 300 107	-06/14 without preliminary setup	S	CAN	C	E	--	--	V	150	B
												305 406 300 113	-06/14 without preliminary setup	S	CAN	C	E	D	L1	V	150	B
												305 407 300 107	06/14- with preliminary setup	S	CAN	C	E	--	--	H		B
												305 407 300 113	06/14- with preliminary setup	S	CAN	C	E	D	L	H		B
												305 408 300 107	06/14- without preliminary setup	S	CAN	C	E	--	--	V		B
												305 408 300 113	06/14- without preliminary setup	S	CAN	C	E	D	L	V		B
Audi A3 Saloon Please order spoiler inc. cover for bumper cutout at Audi-dealers.	09/13-06/14	KIT		317 132 900 113		60	21.0	10.3	80	2000		included in the KIT	-06/14 without preliminary setup	S	CAN	C	E	D	L1	V	150	B
Audi A3 Saloon	09/13-06/14	KIT		317 131 900 113		60	21.0	10.3	85	2000		included in the KIT	-06/14 without preliminary setup	S	CAN	C	E	D	L1	V	150	B
Audi A3 Saloon Please order separately spoiler at Audi dealer.	06/14-	KIT		305 409 900 113		60	21.0	10.3	85	2000		included in the KIT	06/14- without preliminary setup	S	CAN	C	E	D	L	V		B
Audi A3 Saloon	06/14-	KIT		305 408 900 113		60	19.0	10.3	85	2000		included in the KIT	06/14- without preliminary setup	S	CAN	C	E	D	L	V		B
Audi A3 Sportback inc. Quattro, V6 3,2 l (250 HP), Facelift 06/08- models S3 04/08-: Please check if the vehicle is allowed for towing trailers by the car manufacturer.	09/04-			305 299 600 001		120	16.5	9.7	100	1800		305 256 300 107		S	CAN	C	E	--	--	V	120	B
												305 256 300 113		S	CAN	C	E	D	--	V	120	B
												KIT		305 299 900 113		120	18.5	9.7	100	1800		included in the KIT









Audi

Audi A3 Sportback inc. Quattro, S-Line, V6 3,2l (250 HP), Facelift 06/08- models S3 04/08-: Please check if the vehicle is allowed for towing trailers by the car manufacturer. For optimal fit, order spoiler and cover at Audi dealers.	09/04-		305 300 600 001		120	17.5	9.7	100	1800	305 256 300 107		S	CAN	C	E	--	--	V	120	B	
												305 256 300 113	S	CAN	C	E	D	--	V	120	B
			KIT			305 300 900 113		120	18.5	9.7		100	1800	included in the KIT	S	CAN	C	E	D	--	V
Audi A3 Sportback	02/13-		317 131 600 001		60	19.0	10.3	80	2000	305 403 300 107	-06/14 with preliminary setup	S	CAN	C	E	--	--	H	45	B	
										305 403 300 113	-06/14 with preliminary setup	S	CAN	C	E	--	--	H	45	B	
										305 406 300 107	-06/14 without preliminary setup	S	CAN	C	E	--	--	V	150	B	
										305 406 300 113	-06/14 without preliminary setup	S	CAN	C	E	D	L1	V	150	B	
										305 407 300 107	06/14- with preliminary setup	S	CAN	C	E	--	--	H		B	
										305 407 300 113	06/14- with preliminary setup	S	CAN	C	E	D	L	H		B	
										305 408 300 107	06/14- without preliminary setup	S	CAN	C	E	--	--	V		B	
										305 408 300 113	06/14- without preliminary setup	S	CAN	C	E	D	L	V		B	

















Audi A3 Sportback Please order spoiler inc. cover for bumper cutout at Audi-dealers.	02/13-			317 132 600 001		60	19.0	10.3	80	2000		305 403 300 107	-06/14 with preliminary setup	S	CAN	C	E	--	--	H	45	B
												305 403 300 113	-06/14 with preliminary setup	S	CAN	C	E	--	--	H	45	B
												305 406 300 107	-06/14 without preliminary setup	S	CAN	C	E	--	--	V	150	B
												305 406 300 113	-06/14 without preliminary setup	S	CAN	C	E	D	L1	V	150	B
												305 407 300 107	06/14- with preliminary setup	S	CAN	C	E	--	--	H		B
												305 407 300 113	06/14- with preliminary setup	S	CAN	C	E	D	L	H		B
												305 408 300 107	06/14- without preliminary setup	S	CAN	C	E	--	--	V		B
305 408 300 113	06/14- without preliminary setup	S	CAN	C	E	D	L	V		B												
Audi A3 Sportback	02/13-06/14	KIT		317 131 900 113		60	21.0	10.3	85	2000		included in the KIT	-06/14 without preliminary setup	S	CAN	C	E	D	L1	V	150	B
Audi A3 Sportback Please order spoiler inc. cover for bumper cutout at Audi-dealers.	02/13-06/14	KIT		317 132 900 113		60	21.0	10.3	80	2000		included in the KIT	-06/14 without preliminary setup	S	CAN	C	E	D	L1	V	150	B
Audi A3 Sportback Please order spoiler inc. cover for bumper cutout at Audi-dealers.	06/14-	KIT		305 409 900 113		60	21.0	10.3	85	2000		included in the KIT	06/14- without preliminary setup	S	CAN	C	E	D	L	V		B
Audi A3 Sportback	06/14-	KIT		305 408 900 113		60	19.0	10.3	85	2000		included in the KIT	06/14- without preliminary setup	S	CAN	C	E	D	L	V		B
Audi A3, 3 doors front wheel drive inc. Quattro, S3 04/06-, V6 3,2 l (250 HP) models S3 04/08-: Please check if the vehicle is allowed for towing trailers by the car manufacturer.	05/03-	KIT		305 389 900 113		60	19.0	9.4	100	1700		included in the KIT		S	CAN	C	E	D	--	V	120	B
				305 390 900 113																		

























Audi

Audi A3, 3 doors front wheel drive inc. Quattro, inc. S3 04/06-, inc. V6 3,2 l, 250 HP models S3 04/08-: Please check if the vehicle is allowed for towing trailers by the car manufacturer. Please order separately spoiler inc. cover at Audi dealers.	04/08-		321 865 600 001		60	17.0	9.4	100	1800	305 256 300 107			S	CAN	C	E	--	--	V	120	B
										305 256 300 113			S	CAN	C	E	D	--	V	120	B
Audi A3, 3 doors front wheel drive inc. Quattro, inc. S-Line and S3 04/06-, inc. V6 3,2 l, 250 HP models S3 04/08-: Please check if the vehicle is allowed for towing trailers by the car manufacturer. Please order separately spoiler inc. cover at Audi dealers.	04/08-04/12		321 885 600 001		60	17.0	9.4	100	1800	305 256 300 113			S	CAN	C	E	D	--	V	120	B
Audi A3, 3 doors Please order spoiler inc. cover for bumper cutout at Audi-dealers.	05/12-		317 132 600 001		60	19.0	10.3	80	2000	305 403 300 107	-06/14 with preliminary setup	S	CAN	C	E	--	--	H	45	B	
										305 403 300 113	-06/14 with preliminary setup	S	CAN	C	E	--	--	H	45	B	
										305 406 300 107	-06/14 without preliminary setup	S	CAN	C	E	--	--	V	150	B	
										305 406 300 113	-06/14 without preliminary setup	S	CAN	C	E	D	L1	V	150	B	
										305 407 300 107	06/14- with preliminary setup	S	CAN	C	E	--	--	H		B	
										305 407 300 113	06/14- with preliminary setup	S	CAN	C	E	D	L	H		B	
										305 408 300 107	06/14- without preliminary setup	S	CAN	C	E	--	--	V		B	
305 408 300 113	06/14- without preliminary setup	S	CAN	C	E	D	L	V		B											
Audi A3, 3 doors	05/12-06/14	KIT 	317 131 900 113		60	21.0	10.3	85	2000	included in the KIT			S	CAN	C	E	D	L1	V	150	B
Audi A3, 3 doors Please order spoiler inc. cover for bumper cutout at Audi-dealers.	05/12-06/14	KIT 	317 132 900 113		60	21.0	10.3	80	2000	included in the KIT			S	CAN	C	E	D	L1	V	150	B



























Audi A3, 3 doors	02/13-			317 131 600 001		60	19.0	10.3	80	2000		305 403 300 107	-06/14 with preliminary setup	S	CAN	C	E	--	--	H	45	B	
												305 403 300 113	-06/14 with preliminary setup	S	CAN	C	E	--	--	H	45	B	
												305 406 300 107	-06/14 without preliminary setup	S	CAN	C	E	--	--	V	150	B	
												305 406 300 113	-06/14 without preliminary setup	S	CAN	C	E	D	L1	V	150	B	
												305 407 300 107	06/14- with preliminary setup	S	CAN	C	E	--	--	H			B
												305 407 300 113	06/14- with preliminary setup	S	CAN	C	E	D	L	H			B
												305 408 300 107	06/14- without preliminary setup	S	CAN	C	E	--	--	V			B
												305 408 300 113	06/14- without preliminary setup	S	CAN	C	E	D	L	V			B
Audi A3, 3 doors Please order spoiler inc. cover for bumper cutout at Audi-dealers.	06/14-	KIT		305 409 900 113		60	21.0	10.3	85	2000		included in the KIT	06/14- without preliminary setup	S	CAN	C	E	D	L	V		B	
Audi A3, 3 doors	06/14-	KIT		305 408 900 113		60	19.0	10.3	85	2000		included in the KIT	06/14- without preliminary setup	S	CAN	C	E	D	L	V		B	
Audi A4 Allroad Quattro B8 inc. S-Line, Quattro Sport exc.RS For S4 please order extended socket holder, order no. 905323608001. Please order separately the moulded towball holder 8T0 012 109 C at Audi-dealers. Attention: Depending on the engine variation it may be necessary to change the cooling system of the vehicle.	06/09-	KIT		305 425 900 113		90	20.0	11.0	90	2000		included in the KIT		S	CAN	C	E	D	L1	H	60	B	

























Audi



















Audi A4 Allroad Quattro B8 inc. S4, S-Line, Quattro Sport exc.RS For S4 please order extended socket holder, order no. 905323608001. Please order separately the moulded towball holder 8T0 012 109 C at Audi-dealers. Attention: Depending on the engine variation it may be necessary to change the cooling system of the vehicle.	06/09-		305 445 600 001		90	18.0	11.1	80	2000	305 214 300 107		S	CAN	C	E	--	--	H	60	B	
											305 214 300 113		S	CAN	C	E	D	L1	H	60	B
Audi A4 Avant inc. Quattro + S4 exc. RS 4	01/96-11/01		305 179 600 001		150	18.0	10.1	75	1800	305 160 300 173	additional kit for checkcontrol (Please order additionally)	S	--	--	E1	--	--	V	45	L	
			305 220 600 001		120	19.0	10.1	75	1800	305 221 300 113		S	FRE	--	E	D1	L1	V	60	B	
		KIT		305 394 900 113		150	20.0	10.1	75	1800	305 160 300 173	additional kit for checkcontrol (Please order additionally)	S	--	--	E1	--	--	V	45	L
		KIT		305 395 900 113		120	21.0	10.1	75	1800	included in the KIT		S	FRE	--	E	D1	L1	V	60	B
Audi A4 Avant B6 Quattro and S-Line, exc. S4	11/01-11/04		305 205 600 001		120	18.5	10.3	85	2000	305 215 300 107		S	CAN	C	E	--	--	H	75	B	
			305 206 600 001		120	20.0	10.3	85	2000	305 215 300 113		S	CAN	C	E	D1	--	H	75	B	
		KIT		305 205 900 113		120	20.5	10.3	85	2000	included in the KIT										
		KIT		305 206 900 113		120	22.0	10.3	85	2000		S	CAN	C	E	D1	--	H	75	B	

Audi A4 Avant B7 inc. Quattro, S-line exc. RS4/S4	11/04-08			305 301 600 001		120	20.0	10.4	100	2000		305 208 300 147			S	CAN	C	E1	--	--	H	100	R	
				305 302 600 001		120	20.0	10.4	100	2000		305 208 300 153			S	CAN	C	E1	D1	L1	H	100	R	
		KIT		305 301 900 113		120	22.0	10.4	100	2000		included in the KIT			S	CAN	C	E	D1	L1	V	105	L	
				305 302 900 113		120	22.0	10.4	100	2000						S	CAN	C	E	D1	L1	V	105	L
Audi A4 Avant B7 inc. Quattro, S-line exc. RS4/S4 for right-hand-drive vehicles	11/04-08	KIT		305 301 900 153		120	22.0	10.4	100	2000		included in the KIT			S	CAN	C	E1	D1	L1	H	100	R	
				305 302 900 153		120	22.0	10.4	100	2000						S	CAN	C	E1	D1	L1	H	100	R
Audi A4 Avant B8 inc. S4, S-Line, Quattro exc.RS Attention: Depending on the engine variation it may be necessary to change the cooling system of the vehicle.	04/08-	KIT		305 443 600 001		90	19.0	11.0	90	2000		305 214 300 107			S	CAN	C	E	--	--	H	60	B	
				305 324 900 113		90	21.0	11.0	90	2000		305 214 300 113			S	CAN	C	E	D	L1	H	60	B	
Audi A4 Avant B8 inc. S4, S-Line, Quattro Sport exc.RS For S4 please order extended socket holder, order no. 905323608001. Please order separately the moulded towball holder 8T0 012 109 C at Audi-dealers. Attention: Depending on the engine variation it may be necessary to change the cooling system of the vehicle.	04/08-	KIT		305 445 600 001		90	18.0	11.1	80	2000		305 214 300 107			S	CAN	C	E	--	--	H	60	B	
				305 425 900 113		90	20.0	11.0	90	2000		305 214 300 113			S	CAN	C	E	D	L1	H	60	B	
Audi A4 Convertible B6, exc. S4	05/02-05	KIT		305 205 600 001		120	18.5	10.3	85	2000		305 215 300 107			S	CAN	C	E	--	--	H	75	B	
				305 205 900 113		120	20.5	10.3	85	2000		305 215 300 113			S	CAN	C	E	D1	--	H	75	B	



























Audi





























Audi A4 Convertible B6 inc. S-Line, exc. S4	05/02-05			305 206 600 001		120	20.0	10.3	85	2000		305 215 300 107			S	CAN	C	E	--	--	H	75	B		
												305 215 300 113			S	CAN	C	E	D1	--	H	75	B		
		KIT		305 206 900 113		120	22.0	10.3	85	2000		included in the KIT			S	CAN	C	E	D1	--	H	75	B		
Audi A4 Convertible B7 inc. S-line exc. RS4/S4	10/05-			305 301 600 001		120	20.0	10.4	100	2000		305 208 300 147			S	CAN	C	E1	--	--	H	100	R		
												305 208 300 153			S	CAN	C	E1	D1	L1	H	100	R		
						305 302 600 001		120	20.0	10.4	100	2000		305 210 300 113			S	CAN	C	E	D1	L1	V	105	L
			KIT		305 301 900 113		120	22.0	10.4	100	2000		included in the KIT			S	CAN	C	E	D1	L1	V	105	L	
		KIT		305 302 900 113		120	22.0	10.4	100	2000					S	CAN	C	E	D1	L1	V	105	L		
Audi A4 Convertible B7 inc. S-line exc. RS4/S4 for right-hand-drive vehicles	10/05-	KIT		305 301 900 153		120	22.0	10.4	100	2000		included in the KIT			S	CAN	C	E1	D1	L1	H	100	R		
		KIT		305 302 900 153		120	22.0	10.4	100	2000					S	CAN	C	E1	D1	L1	H	100	R		
Audi A4 Saloon B5 inc. Quattro + S4	11/94-11/00			305 179 600 001		150	18.0	10.1	75	1800		300 078 300 113	03/99-	--	FRE	--	--	D1	L1	V			B		
												305 160 300 173	additional kit for checkcontrol (Please order additionally)	S	--	--	E1	--	--	V	45	L			
					305 220 600 001		120	19.0	10.1	75	1800		305 177 300 107	-02/99	S	FRE	--	E	--	--	V	45	L		
Audi A4 Saloon B6 Quattro and S-Line, exc. S4	11/00-11/04			305 205 600 001		120	18.5	10.3	85	2000		305 215 300 107			S	CAN	C	E	--	--	H	75	B		
												305 215 300 113			S	CAN	C	E	D1	--	H	75	B		
			KIT		305 205 900 113		120	20.5	10.3	85	2000		included in the KIT			S	CAN	C	E	D1	--	H	75	B	
			KIT		305 206 900 113		120	22.0	10.3	85	2000					S	CAN	C	E	D1	--	H	75	B	

Audi A4 Saloon B7 inc. Quattro, S-line exc. RS4/S4	11/04-09/07			305 301 600 001		120	20.0	10.4	100	2000	305 210 300 113				S	CAN	C	E	D1	L1	V	105	L	
				305 302 600 001		120	20.0	10.4	100	2000														
		KIT		305 301 900 113		120	22.0	10.4	100	2000														included in the KIT
		KIT		305 302 900 113		120	22.0	10.4	100	2000														
Audi A4 Saloon B7 inc. Quattro, S-line exc. RS4/S4 for right-hand-drive vehicles	11/04-09/07	KIT		305 301 900 153		120	22.0	10.4	100	2000	included in the KIT				S	CAN	C	E1	D1	L1	H	100	R	
		KIT		305 302 900 153		120	22.0	10.4	100	2000														
Audi A4 Saloon B8 inc. S4, S-Line, Quattro exc.RS Attention: Depending on the engine variation it may be necessary to change the cooling system of the vehicle.	09/07-			305 443 600 001		90	19.0	11.0	90	2000	305 214 300 107 305 214 300 113				S	CAN	C	E	--	--	H	60	B	
		KIT		305 324 900 113		90	21.0	11.0	90	2000														included in the KIT
Audi A4 Saloon B8 inc. S4, S-Line, Quattro Sport exc.RS For S4 please order extended socket holder, order no. 905323608001. Please order separately the moulded towball holder 8T0 012 109 C at Audi-dealers. Attention: Depending on the engine variation it may be necessary to change the cooling system of the vehicle.	09/07-			305 445 600 001		90	18.0	11.1	80	2000	305 214 300 107 305 214 300 113				S	CAN	C	E	--	--	H	60	B	
		KIT		305 425 900 113		90	20.0	11.0	90	2000														included in the KIT
Audi A5 Convertible B8 inc. S5, S-Line, Quattro exc.RS Attention: Depending on the engine variation it may be necessary to change the cooling system of the vehicle.	09-			305 443 600 001		90	19.0	11.0	90	2000	305 214 300 107 305 214 300 113				S	CAN	C	E	--	--	H	60	B	
		KIT		305 324 900 113		90	21.0	11.0	90	2000														included in the KIT



























Audi A5 Sportback B8 inc. S5, S-Line, Quattro Sport exc.RS For S5 please order extended socket holder, order no. 905323608001. Please order separately the moulded towball holder 8T0 012 109 C at Audi-dealers. Attention: Depending on the engine variation it may be necessary to change the cooling system of the vehicle.	09/09-			305 445 600 001		90	18.0	11.1	80	2000		305 214 300 107			S	CAN	C	E	--	--	H	60	B	
													305 214 300 113			S	CAN	C	E	D	L1	H	60	B
		KIT		305 425 900 113		90	20.0	11.0	90	2000		included in the KIT			S	CAN	C	E	D	L1	H	60	B	
Audi A6 Allroad Quattro Aluminium bumper carrier can only be obtained from Audi, Audi- order-no.: 4Z7 807 313A	05/00-05			305 225 600 001		120	25.2	11.8	95	2300		305 191 300 107			S	FRE	--	E	--	--	V	105	B	
													305 191 300 113			S	FRE	--	E	D	L1	V	105	B
Audi A6 Allroad Please order spoiler at Audi dealers.	05/06-06/12			305 309 600 001		90	31.0	12.0	90	2200		305 268 300 113			S	CAN	C	E	D	L1	H	45	B	
		KIT		305 309 900 113		90	33.0	12.0	90	2200		included in the KIT			S	CAN	C	E	D	L1	H	45	B	
Audi A6 Allroad	06/12-			305 407 600 001		90	20.0	12.6	100	2500		305 385 300 113	-10/14		S	CAN	C	E	D	L1	H	45	B	
													305 386 300 113	10/14-	S	CAN	C	E	D	L	H		B	
Audi A6 Allroad	06/12-10/14	KIT		305 407 900 113		90	22.0	12.6	100	2500		included in the KIT	-10/14	S	CAN	C	E	D	L1	H	45	B		
Audi A6 Avant front wheel drive, without height control	97-03/05			305 247 600 001		120	21.8	11.0	85	2100		305 191 300 107			S	FRE	--	E	--	--	V	105	B	
					305 243 600 001		120	22.8	11.0	85	2100		305 191 300 113			S	FRE	--	E	D	L1	V	105	B
		KIT		305 247 900 113		120	23.8	11.0	85	2100		included in the KIT			S	FRE	--	E	D	L1	V	105	B	
		KIT		305 243 900 113		120	25.0	11.0	85	2100					S	FRE	--	E	D	L1	V	105	B	



























Audi









Audi A6 Avant front wheel drive, with height control	97-03/05			305 248 600 001	→ 	120	20.6	11.0	85	2100	305 191 300 107			S	FRE	--	E	--	--	V	105	B
				305 244 600 001	→ 	120	22.2	11.0	85	2100				305 191 300 113	S	FRE	--	E	D	L1	V	105
Audi A6 Avant Quattro, without height control, exc. RS6	97-03/05			305 249 600 001		120	21.7	11.0	85	2100	305 191 300 107			S	FRE	--	E	--	--	V	105	B
				305 245 600 001		120	23.0	11.0	85	2100	305 191 300 113			S	FRE	--	E	D	L1	V	105	B
Audi A6 Avant Quattro, with height control, exc. RS6	97-03/05			305 250 600 001	→ 	120	21.0	11.0	85	2100	305 191 300 107			S	FRE	--	E	--	--	V	105	B
				305 246 600 001		120	22.5	11.0	85	2100	305 191 300 113			S	FRE	--	E	D	L1	V	105	B
Audi A6 Avant with steel springs inc. S6 and Quattro, exc. RS6 To guarantee an optimal fit of the bumper it is necessary to mount a bumper reinforcement. Please order from Westfalia no. 905269619001 in combination with Audi no. 4F0 807 381. Please order separately cover for bumper cutout from Audi dealers.	03/05-			305 274 600 001		120	19.0	12.0	90	2200	305 268 300 113			S	CAN	C	E	D	L1	H	45	B
				305 269 600 001		120	21.5	12.0	90	2200												
			KIT		305 274 900 113		120	21.0	12.0	90	2200	included in the KIT	S	CAN	C	E	D	L1	H	45	B	
Audi A6 Avant with steel springs inc. S6 and Quattro, exc. RS6	03/05-	KIT		305 269 900 113		120	22.5	12.0	90	2200	included in the KIT			S	CAN	C	E	D	L1	H	45	B
Audi A6 Avant with height control inc. Quattro, S6, S-line, exc. RS6 For optimal fit, order bumper reinforcement Westfalia no. 905269619001 in combination with Audi no. 4F0 807 381.	03/05-			305 291 600 001		120	24.5	12.0	90	2200	305 268 300 113			S	CAN	C	E	D	L1	H	45	B
Audi A6 Avant with steel springs S-line To guarantee an optimal fit of the bumper it is necessary to mount a bumper reinforcement. Please order from Westfalia no. 905269619001 in combination with Audi no. 4F0 807 381.	03/05-			305 398 600 001		120	23.0	12.0	90	2200	305 268 300 113			S	CAN	C	E	D	L1	H	45	B
			KIT		305 398 900 113		120	25.0	12.0	90	2200											

Audi A6 Avant exc. RS6	09/11-			305 428 600 001		90	20.0	12.6	100	2500		305 385 300 113	-10/14	S	CAN	C	E	D	L1	H	45	B
				305 429 600 001		90	21.0	12.6	100	2500		305 386 300 113	10/14-	S	CAN	C	E	D	L	H		
Audi A6 Avant exc. RS6	09/11-10/14	KIT		305 428 900 113		90	22.0	12.6	100	2500		included in the KIT	-10/14	S	CAN	C	E	D	L1	H	45	B
				305 429 900 113		90	23.0	12.6	100	2500												
Audi A6 Avant exc. RS6	10/14-	KIT		305 438 900 113			22.0	12.6	100	2500		included in the KIT	10/14-	S	CAN	C	E	D	L	H		B
				305 439 900 113			23.0	12.6	100	2500												
Audi A6 Saloon front wheel drive, without height control	97-04/04			305 247 600 001		120	21.8	11.0	85	2100		305 191 300 107		S	FRE	--	E	--	--	V	105	B
				305 243 600 001		120	22.8	11.0	85	2100		305 191 300 113		S	FRE	--	E	D	L1	V	105	B
Audi A6 Saloon front wheel drive, with height control	97-04/04			305 248 600 001	→ 	120	20.6	11.0	85	2100		305 191 300 107		S	FRE	--	E	--	--	V	105	B
				305 244 600 001	→ 	120	22.2	11.0	85	2100		305 191 300 113		S	FRE	--	E	D	L1	V	105	B
Audi A6 Saloon Quattro, with height control, exc. RS6	97-04/04			305 249 600 001		120	21.7	11.0	85	2100		305 191 300 107		S	FRE	--	E	--	--	V	105	B
				305 245 600 001		120	23.0	11.0	85	2100		305 191 300 113		S	FRE	--	E	D	L1	V	105	B
Audi A6 Saloon Quattro, with height control, exc. RS6	97-04/04			305 250 600 001	→ 	120	21.0	11.0	85	2100		305 191 300 107		S	FRE	--	E	--	--	V	105	B
				305 246 600 001		120	22.5	11.0	85	2100		305 191 300 113		S	FRE	--	E	D	L1	V	105	B















Audi































Audi A6 Saloon with steel springs inc. S6 and Quattro, exc. RS6	04/04-			305 274 600 001		120	19.0	12.0	90	2200	305 268 300 113				S	CAN	C	E	D	L1	H	45	B
				305 269 600 001		120	21.5	12.0	90	2200													
	KIT			305 274 900 113		120	21.0	12.0	90	2200	included in the KIT				S	CAN	C	E	D	L1	H	45	B
		KIT		305 269 900 113		120	22.5	12.0	90	2200													
Audi A6 Saloon with height control inc. Quattro, S6, S-Line, exc. RS6	04/04-			305 291 600 001		120	24.5	12.0	90	2200	305 268 300 113				S	CAN	C	E	D	L1	H	45	B
Audi A6 Saloon with steel springs S-line	04/04-			305 398 600 001		120	23.0	12.0	90	2200	305 268 300 113				S	CAN	C	E	D	L1	H	45	B
		KIT		305 398 900 113		120	25.0	12.0	90	2200	included in the KIT				S	CAN	C	E	D	L1	H	45	B
Audi A6 Saloon	03/11-			305 428 600 001		90	20.0	12.6	100	2500	305 385 300 113	-10/14			S	CAN	C	E	D	L1	H	45	B
				305 429 600 001		90	21.0	12.6	100	2500	305 386 300 113	10/14-			S	CAN	C	E	D	L	H		
Audi A6 Saloon	03/11-10/14	KIT		305 428 900 113		90	22.0	12.6	100	2500	included in the KIT	-10/14			S	CAN	C	E	D	L1	H	45	B
		KIT		305 429 900 113		90	23.0	12.6	100	2500													
Audi A6 Saloon	10/14-	KIT		305 438 900 113			22.0	12.6	100	2500	included in the KIT	10/14-			S	CAN	C	E	D	L	H		B
		KIT		305 439 900 113			23.0	12.6	100	2500													

Audi A7	10/10-			305 428 600 001		90	20.0	12.6	100	2500		305 385 300 113	-10/14	S	CAN	C	E	D	L1	H	45	B	
				305 429 600 001		90	21.0	12.6	100	2500		305 386 300 113	10/14-	S	CAN	C	E	D	L	H			B
Audi A7	10/10-10/14	KIT		305 428 900 113		90	22.0	12.6	100	2500		included in the KIT	-10/14	S	CAN	C	E	D	L1	H	45	B	
		KIT		305 429 900 113		90	23.0	12.6	100	2500													
Audi A7	10/14-	KIT		305 438 900 113			22.0	12.6	100	2500		included in the KIT	10/14-	S	CAN	C	E	D	L	H		B	
		KIT		305 439 900 113			23.0	12.6	100	2500													
Audi A8 inc. S8 + Quattro	11/02-03/10			305 276 600 001		<150	28.4	12.5	95	2430		305 227 300 113		S	CAN	C	E	D	--	H	60	B	
		KIT		305 276 900 113		<150	30.4	12.5	95	2430		included in the KIT		S	CAN	C	E	D	--	H	60	B	
Audi A8	03/10-			305 384 600 001		60	26.0	12.6	100	2200		305 384 300 113	-10/13	S	CAN	C	E	D	L1	H	60	B	
												305 391 300 113	11/13-	S	CAN	C	E	D	L				L
Audi Q3	09/11-			305 421 600 001		90	19.0	12.6	100	2500		305 410 300 107		S	CAN	C	E				V	120	B
				305 423 600 001		90	21.0	12.6	100	2500		305 410 300 113		S	CAN	C	E	D	L1	V	120	B	
		KIT		305 421 900 113		90	21.0	12.6	100	2500		included in the KIT		S	CAN	C	E	D	L1	V	120	B	
		KIT		305 423 900 113		90		12.6	100	2500													













BMW 1 Series Convertible E88 135i is not homologated for towing.	08-			303 323 600 001			60	20.0	8.0	90	1400		303 460 300 107			S	CAN	--	E2	--	--	H	60	B	
														303 460 300 113			S	CAN	--	E2	D	L1	H	60	B
BMW 1 Series Coupé E82 135i is not homologated for towing.	11/07-			303 323 600 001			60	20.0	8.0	90	1400		303 460 300 107			S	CAN	--	E2	--	--	H	60	B	
			KIT		303 323 900 113			60	22.0	8.0	90	1400		included in the KIT			S	CAN	--	E2	D	L1	H	60	B
BMW 1 Series, 3/5 doors Hatchback F20/F21 Please order separately thermal-insulation plate for socket holder,no. 7 277 733 at BMW dealers. 135i is not permitted to tow by manufacturer.	09/11-			303 317 600 001				20.0	8.8	75	1500		303 352 300 107	03/14-											
													303 352 300 113	03/14-											
													303 460 300 107	-03/14	S	CAN	--	E2	--	--	H	60	B		
													303 460 300 113	-03/14	S	CAN	--	E2	D	L1	H	60	B		
BMW 1 Series, 3/5 doors Hatchback F20/F21 135i is not permitted to tow by manufacturer.	09/11-			303 320 600 001				17.5	8.8	75	1500		303 352 300 107	03/14-											
													303 352 300 113	03/14-											
													303 460 300 107	-03/14	S	CAN	--	E2	--	--	H	60	B		
													303 460 300 113	-03/14	S	CAN	--	E2	D	L1	H	60	B		
BMW 1 Series, 3/5 doors Hatchback F20/F21 Please order separately thermal-insulation plate for socket holder,no. 7 277 733 at BMW dealers. 135i is not permitted to tow by manufacturer.	09/11-03/14	KIT		303 317 900 113				22.0	8.8	75	1500		included in the KIT												
																	S	CAN	--	E2	D	L1	H	60	B
BMW 1 Series, 3/5 doors Hatchback F20/F21 135i is not permitted to tow by manufacturer.	09/11-03/14	KIT		303 320 900 113				19.5	8.8	75	1500		included in the KIT												
																	S	CAN	--	E2	D	L1	H	60	B
BMW 1 Series, 3/5 doors Hatchback F20/F21 135i is not permitted to tow by manufacturer.	03/14-	KIT		303 318 900 113				22.0	8.8	75	1500		included in the KIT												













BMW

BMW 3 Series Compact E46 (E46/5) steel construction exc. M3, exc. vehicles with sport equipment Please order separately cover for bumper cutout at BMW dealer' s, BMW no.: model -12/03: 5112 8244 380, model 12/03 -: 5112 7112 481.	06/01-05		303 231 600 001	→ 	17.0	9.9	75	1980		303 140 300 107			S	FRE	--	E	--	--	V	105	L											
										303 140 300 113			S	FRE	--	E	D	L1	V	105	L											
BMW 3 Series Coupé E36 (E36/2) exc. M3 (Please order from BMW Motorsport, Munich)	92-		303 148 600 001	→ 	150	16.4	9.3	75	1800	300 072 300 107			--	FRE	--	--	--	--	V		B											
										300 072 300 113			--	FRE	--	--	D1	L1	V		B											
										300 078 300 113			--	FRE	--	--	D1	L1	V		B											
BMW 3 Series Coupé E46 (E46/2) exc. M3	04/99-08/06		303 153 600 001		150	15.6	9.9	75	1940	303 140 300 107			S	FRE	--	E	--	--	V	105	L											
										303 140 300 113			S	FRE	--	E	D	L1	V	105	L											
		KIT			150	17.6	9.9	75	1940	included in the KIT			S	FRE	--	E	D	L1	V	105	L											
BMW 3 Series Coupé E46 (E46/2) steel construction exc. M3 Please order separately cover for bumper cutout at BMW dealer's, BMW no.: model -12/03: 5112 8244 380, model 12/03 -: 5112 7112 481.	04/99-08/06		303 230 600 001		150	17.0	9.9	75	1940	303 140 300 107			S	FRE	--	E	--	--	V	105	L											
										303 140 300 113			S	FRE	--	E	D	L1	V	105	L											
		KIT			150	19.0	9.9	75	1940	included in the KIT			S	FRE	--	E	D	L1	V	105	L											
BMW 3 Series Coupé E92 angular position of the towball receptor tube is not in centre inc. models 335i and 335td and/or vehicles with turbocharger please order extra carriers for exhaust, order no. 303266600015	09/06-		303 266 600 001			27.0	10.0	75	1800	303 460 300 107			S	CAN	--	E2	--	--	H	60	B											
										303 460 300 113			S	CAN	--	E2	D	L1	H	60	B											
BMW 3 Series Coupé E92 angular position of the towball exc. models 335i and 335td and/ or vehicles with turbocharger	09/06-		303 267 600 001	→		25.5	10.0	75	1800	303 460 300 107			S	CAN	--	E2	--	--	H	60	B											
										303 460 300 113			S	CAN	--	E2	D	L1	H	60	B											
BMW 3 Series Gran Turismo F34 exc. M3, fits M Sport BMW recommend fitting a heat shield for the detachable mechanism on petrol engines only - Order mounting bracket 303352613001 and heat shield separately from BMW dealers.	06/13-		303 366 600 001			60	19.0	10.2	75	1800	303 352 300 107		04/14-																			
											303 352 300 113												04/14-									
											303 460 300 107													S	CAN	--	E2	--	--	H	60	B
											303 460 300 113													-03/14	S	CAN	--	E2	D	L1	H	60









BMW 3 Series Saloon E36 (E36/4) exc. M3 (available form BMW-Motorsport, Munich)	01/91-98			303 148 600 001			150	16.4	9.3	75	1800		300 072 300 113				--	FRE	--	--	D1	L1	V		B												
																										300 078 300 113	--	FRE	--	--	D1	L1	V	B			
BMW 3 Series Saloon E46 exc. M3	04/98-03/05			303 153 600 001			150	15.6	9.9	75	1940		303 140 300 107				S	FRE	--	E	--	--	V	105	L												
																										303 140 300 113	S	FRE	--	E	D	L1	V	105	L		
																										KIT		303 153 900 113			150	17.6	9.9	75	1940		included in the KIT
BMW 3 Series Saloon E46 (E46/2) steel construction exc. M3 Please order separately cover for bumper cutout at BMW dealer's, BMW no.: model -09/01: 5112 8238 819, model 09/01 -: 5112 7045 526	04/98-03/05			303 230 600 001			150	17.0	9.9	75	1940		303 140 300 107				S	FRE	--	E	--	--	V	105	L												
																										303 140 300 113	S	FRE	--	E	D	L1	V	105	L		
																										KIT		303 230 900 113			150	19.0	9.9	75	1940		included in the KIT
BMW 3 Series Saloon E90 exc. M3, fits M Sport angular position of the towball, receptor tube is not in centre With vehicles year of construction 03/05 the fixed towbar attachment bolts on the vehicle must be changed at a BMW garage. For models 335i and 335td and/or vehicles with turbocharger please order extra carriers for exhaust, order no. 303240600015	03/05-			303 330 600 001			75	25.5	10.0	75	1800		303 460 300 107				S	CAN	--	E2	--	--	H	60	B												
																										303 460 300 113	S	CAN	--	E2	D	L1	H	60	B		
																										KIT		303 330 900 113			75	29.0	10.0	75	1800		included in the KIT
BMW 3 Series Saloon E90 exc. M3, fits M Sport angular position of the towball exc. 335i and 335td and/or vehicles with turbocharger With vehicles year of construction 03/05 the fixed towbar attachment bolts on the vehicle must be changed at a BMW garage.	03/05-			303 331 600 001			75	27.0	10.0	75	1800		303 460 300 107				S	CAN	--	E2	--	--	H	60	B												
																										303 460 300 113	S	CAN	--	E2	D	L1	H	60	B		
																										KIT		303 331 900 113			75	29.0	10.0	75	1800		included in the KIT
BMW 3 Series Saloon F30 exc. M3, fits M Sport	02/12-			303 351 600 001			60		10.0	75	1800		303 352 300 107		03/14-																						
																										303 352 300 113		03/14-									
																										303 460 300 107		-03/14	S	CAN	--	E2	--	--	H	60	B
																										303 460 300 113		-03/14	S	CAN	--	E2	D	L1	H	60	B













BMW



























BMW 3 Series Saloon F30 exc. M3, fits M Sport BMW recommend fitting a heat shield for the detachable mechanism on petrol engines only - Order mounting bracket 303352613001 and heat shield separately from BMW dealers.	02/12-			303 352 600 001			60	21.5	10.0	75	1800		303 352 300 107 303 352 300 113 303 460 300 107 303 460 300 113	03/14- 03/14- -03/14 -03/14	S S	CAN CAN	-- --	E2 E2	-- D	-- L1	H H	60 60	B B
BMW 3 Series Saloon F30 exc. M3, fits M Sport	02/12-03/14	KIT		303 351 900 113			60		10.0	75	1800		included in the KIT	-03/14	S	CAN	--	E2	D	L1	H	60	B
BMW 3 Series Saloon F30 exc. M3, fits M Sport BMW recommend fitting a heat shield for the detachable mechanism on petrol engines only - Order mounting bracket 303352613001 and heat shield separately from BMW dealers.	02/12-03/14	KIT		303 352 900 113			60	23.5	10.0	75	1800		included in the KIT	-03/14	S	CAN	--	E2	D	L1	H	60	B
BMW 3 Series Saloon F30 exc. M3, fits M Sport	03/14-	KIT		303 361 900 113				23.0	10.0	75	1800		included in the KIT	03/14-									
BMW 3 Series Saloon F30 exc. M3, fits M Sport BMW recommend fitting a heat shield for the detachable mechanism on petrol engines only - Order mounting bracket 303352613001 and heat shield separately from BMW dealers.	03/14-	KIT		303 362 900 113				23.5	10.0	75	1800		included in the KIT	03/14-									
BMW 3 Series Touring E36 (E36/3) exc. M3 (Please order from BMW Motorsport, Munich)	95-99			303 148 600 001			150	16.4	9.3	75	1800		300 072 300 113 300 078 300 113		--	FRE	--	--	D1	L1	V		B
BMW 3 Series Touring E46 (E46/3)	99-09/05			303 164 600 001			150	15.7	9.9	75	1940		303 140 300 107 303 140 300 113		S	FRE	--	E	--	--	V	105	L
		KIT		303 164 900 113			150	17.7	9.9	75	1940		included in the KIT		S	FRE	--	E	D	L1	V	105	L

BMW 3 Series Touring E46 (E46/3) steel construction Please order separately cover for bumper cutout at BMW dealer' s, BMW no. 5112 8227 569.	99-09/05			303 232 600 001		150	17.0	9.9	75	1940		303 140 300 107			S	FRE	--	E	--	--	V	105	L
		KIT		303 232 900 113		150	19.0	9.9	75	1940		included in the KIT			S	FRE	--	E	D	L1	V	105	L
BMW 3 Series Touring E91 inc. M Sport, exc. M3 angular position of the towball, receptor tube is not in centre For models 335i and 335td and/or vehicles with turbocharger please order extra carriers for exhaust, order no. 303240600015	09/05-			303 330 600 001		75	25.5	10.0	75	1800		303 460 300 107			S	CAN	--	E2	--	--	H	60	B
		KIT		303 330 900 113		75	29.0	10.0	75	1800		included in the KIT			S	CAN	--	E2	D	L1	H	60	B
BMW 3 Series Touring E91 exc. M Sport, exc. M3 angular position of the towball exc. 335i and 335td and/or vehicles with turbocharger	09/05-			303 331 600 001		75	27.0	10.0	75	1800		303 460 300 107			S	CAN	--	E2	--	--	H	60	B
		KIT		303 331 900 113		75	29.0	10.0	75	1800		included in the KIT			S	CAN	--	E2	D	L1	H	60	B
BMW 3 Series Touring F31 exc. M3, fits M Sport	09/12-			303 351 600 001		60		10.0	75	1800		303 352 300 107	03/14-										
												303 352 300 113	03/14-										
												303 460 300 107	-03/14	S	CAN	--	E2	--	--	H	60	B	
												303 460 300 113	-03/14	S	CAN	--	E2	D	L1	H	60	B	
BMW 3 Series Touring F31 exc. M3, fits M Sport BMW recommend fitting a heat shield for the detachable mechanism on petrol engines only - Order mounting bracket 303352613001 and heat shield separately from BMW dealers.	09/12-			303 352 600 001		60	21.5	10.0	75	1800		303 352 300 107	03/14-										
												303 352 300 113	03/14-										
												303 460 300 107	-03/14	S	CAN	--	E2	--	--	H	60	B	
												303 460 300 113	-03/14	S	CAN	--	E2	D	L1	H	60	B	
BMW 3 Series Touring F31 exc. M3, fits M Sport	09/12-03/14	KIT		303 351 900 113		60		10.0	75	1800		included in the KIT	-03/14		S	CAN	--	E2	D	L1	H	60	B
BMW 3 Series Touring F31 exc. M3, fits M Sport BMW recommend fitting a heat shield for the detachable mechanism on petrol engines only - Order mounting bracket 303352613001 and heat shield separately from BMW dealers.	09/12-03/14	KIT		303 352 900 113		60	23.5	10.0	75	1800		included in the KIT	-03/14		S	CAN	--	E2	D	L1	H	60	B

















BMW

























BMW 3 Series Touring F31 exc. M3, fits M Sport	03/14-	KIT		303 361 900 113				23.0	10.0	75	1800		included in the KIT	03/14-																
BMW 3 Series Touring F31 exc. M3, fits M Sport BMW recommend fitting a heat shield for the detachable mechanism on petrol engines only - Order mounting bracket 303352613001 and heat shield separately from BMW dealers.	03/14-	KIT		303 362 900 113				23.5	10.0	75	1800		included in the KIT	03/14-																
BMW 4 Series Convertible F33 fits M Sport	03/14-			303 351 600 001			60		10.0	75	1800		303 352 300 107 303 352 300 113																	
		KIT		303 361 900 113				23.0	10.0	75	1800		included in the KIT																	
BMW 4 Series Convertible F33 fits M Sport BMW recommend fitting a heat shield for the detachable mechanism on petrol engines only - Order mounting bracket 303352613001 and heat shield separately from BMW dealers.	03/14-			303 352 600 001			60	21.5	10.0	75	1800		303 352 300 107 303 352 300 113																	
		KIT		303 362 900 113				23.5	10.0	75	1800		included in the KIT																	
BMW 4 Series Coupé F32 fits M Sport	10/13-			303 351 600 001			60		10.0	75	1800		303 352 300 107 303 352 300 113 303 460 300 107 303 460 300 113	03/14- 03/14- -03/14 -03/14	S S	CAN CAN	-- --	E2 E2	-- D	-- L1	H H	60 60	B B							
				303 352 600 001			60	21.5	10.0	75	1800		303 352 300 107 303 352 300 113 303 460 300 107 303 460 300 113	03/14- 03/14- -03/14 -03/14	S S	CAN CAN	-- --	E2 E2	-- D	-- L1	H H	60 60	B B							
BMW 4 Series Coupé F32 fits M Sport	10/13-03/14	KIT		303 351 900 113			60		10.0	75	1800		included in the KIT	-03/14	S	CAN	--	E2	D	L1	H	60	B							

BMW 4 Series Coupé F32 fits M Sport BMW recommend fitting a heat shield for the detachable mechanism on petrol engines only - Order mounting bracket 303352613001 and heat shield separately from BMW dealers.	10/13-03/14	KIT		303 352 900 113		60	23.5	10.0	75	1800		included in the KIT	-03/14	S	CAN	--	E2	D	L1	H	60	B
BMW 4 Series Coupé F32 fits M Sport	03/14-	KIT		303 361 900 113			23.0	10.0	75	1800		included in the KIT	03/14-									
BMW 4 Series Coupé F32 fits M Sport BMW recommend fitting a heat shield for the detachable mechanism on petrol engines only - Order mounting bracket 303352613001 and heat shield separately from BMW dealers.	03/14-	KIT		303 362 900 113			23.5	10.0	75	1800		included in the KIT	03/14-									
BMW 4 Series Gran Coupé F36 fits M Sport	06/14-			303 351 600 001		60		10.0	75	1800		303 352 300 107 303 352 300 113										
		KIT		303 361 900 113			23.0	10.0	75	1800		included in the KIT										
BMW 4 Series Gran Coupé F36 fits M Sport BMW recommend fitting a heat shield for the detachable mechanism on petrol engines only - Order mounting bracket 303352613001 and heat shield separately from BMW dealers.	06/14-			303 352 600 001		60	21.5	10.0	75	1800		303 352 300 107 303 352 300 113										
		KIT		303 362 900 113			23.5	10.0	75	1800		included in the KIT										
BMW 5 Series Gran Turismo F07 Please order additionally lower part of the bumper at BMW dealer.	09/09-07/13			303 336 600 001		90	17.0	11.9	100	2100		303 460 300 107 303 460 300 113		S	CAN	--	E2	--	--	H	60	B
														S	CAN	--	E2	D	L1	H	60	B
BMW 5 Series Gran Turismo F07 facelift Please order additionally lower part of the bumper at BMW dealer.	07/13-			303 370 600 001		90	17.0	11.9	100	2100		303 352 300 107 303 352 300 113	03/14- 03/14-									
		KIT		303 370 900 113		90	19.0	11.9	100	2100		included in the KIT	03/14-									

















BMW 5 Series Touring E39/2 inc. vehicles with BMW-sport- equipment	03/97-06/04			303 151 600 001		>150	15.2	11.4	90	2200		303 123 300 113			S	FRE	--	E	D1	L1	V	90	B	
		KIT		303 151 900 113		>150	17.2	11.4	90	2200		included in the KIT			S	FRE	--	E	D1	L1	V	90	B	
BMW 5 Series Touring E39/2 steel construction inc. vehicles with BMW sport equipment Please order separately cover for bumper cutout at BMW dealer's, BMW no. 5112 8221 586.	03/97-06/04			303 229 600 001		>150	17.5	11.4	90	2200		303 123 300 113			S	FRE	--	E	D1	L1	V	90	B	
		KIT		303 229 900 113		>150	19.5	11.4	90	2200		included in the KIT			S	FRE	--	E	D1	L1	V	90	B	
BMW 5 Series Touring E61 exc. M5, inc. vehicles with sport equipment	07/04-09/10			303 212 600 001		150	16.5	11.4	90	2200		303 460 300 107	-07/13		S	CAN	--	E2	--	--	H	60	B	
		KIT		303 212 900 113		150	18.5	11.4	90	2200		included in the KIT		-07/13	S	CAN	--	E2	D	L1	H	60	B	
BMW 5 Series Touring E61 exc. M5, only for vehicles with sport equipment Please order separately cover for bumper cutout 5112 7126 377 at BMW dealer's.	07/04-09/10			303 235 600 001			20.0	11.4	90	2200		303 460 300 107	-07/13		S	CAN	--	E2	--	--	H	60	B	
		KIT		303 235 900 113			22.0	11.4	90	2200		included in the KIT		-07/13	S	CAN	--	E2	D	L1	H	60	B	
BMW 5 Series Touring E61 exc. M5, exc. vehicles with sport equipment	07/04-09/10			303 294 600 001		100	20.0	11.4	90	2200		303 460 300 107	-07/13		S	CAN	--	E2	--	--	H	60	B	
		KIT		303 294 900 113		100	22.0	11.4	90	2200		included in the KIT		-07/13	S	CAN	--	E2	D	L1	H	60	B	
BMW 5 Series Touring F11	09/10-			303 397 600 001		45		11.8	100	2200		303 352 300 107	07/13-											
				303 398 600 001		45		11.8	100	2200		303 352 300 113	07/13-											
												303 460 300 107	-07/13		S	CAN	--	E2	--	--	H	60	B	
														S	CAN	--	E2	D	L1	H	60	B		
BMW 5 Series Touring F11	09/10-07/13	KIT		303 337 900 113			25.0	11.8	100	2200														
		KIT		303 338 900 113		45		11.8	100	2200		included in the KIT		-07/13	S	CAN	--	E2	D	L1	H	60	B	









BMW





























BMW 5 Series Touring F11	07/13-	KIT		303 370 900 113		90	19.0	11.9	100	2100		included in the KIT	07/13-												
BMW 6 Series is not permitted to tow by manufacturer.																									
BMW M5, E60/E61 from 2004- Towbar is only available at the BMW dealer's.																									
BMW X1 exc. BMW factory fit bike rack	10/09-			303 313 600 001	→	90	17.0	10.3	80	2000		303 352 300 107	04/14-												
				303 393 600 001		90	17.0	10.3	80	2000		303 352 300 113	04/14-												
				303 314 600 001	→	90	18.0	10.3	80	2000		303 460 300 107	-03/14	S	CAN	--	E2	--	--	H	60			B	
				303 394 600 001		90	18.0	10.3	80	2000		303 460 300 113	-03/14	S	CAN	--	E2	D	L1	H	60			B	
BMW X1 exc. BMW factory fit bike rack	10/09-03/14	KIT		303 313 900 113		90	19.0	10.3	80	2000		included in the KIT	-03/14	S	CAN	--	E2	D	L1	H	60			B	
		KIT		303 314 900 113		90	20.0	10.3	80	2000															
BMW X1 exc. BMW factory fit bike rack	04/14-	KIT		303 393 900 113			19.0	10.3	80	2000		included in the KIT	04/14-												
		KIT		303 394 900 113			20.0	10.3	80	2000															
BMW X3 Depending upon equipment partial cutout + cover is necessary. Please order separately with the BMW dealer.	01/04-11/10			303 304 600 001			21.0	12.6	100	2200		303 189 300 113		S	FRE	--	E	D	L1	V	120			B	
		KIT		303 304 900 113			23.0	12.6	100	2200		included in the KIT		S	FRE	--	E	D	L1	V	120			B	



























BMW X3	01/04-11/10			303 327 600 001		16.0	10.9	85	2000		303 189 300 113			S	FRE	--	E	D	L1	V	120	B	
		KIT		303 327 900 113		18.0	10.9	85	2000		included in the KIT			S	FRE	--	E	D	L1	V	120	B	
BMW X3 F25 exc. M-Sport	11/10-			303 339 600 001		60	20.0	12.0	100	2400	303 352 300 107	10/14-											
				303 340 600 001	→ 	60	21.0	12.0	100	2400	303 460 300 107	10/14-	-09/14	S	CAN	--	E2	--	--	H	60	B	
				303 404 600 001		60	21.0	12.6	100	2400	303 460 300 113	-09/14	-09/14	S	CAN	--	E2	D	L1	H	60	B	
BMW X3 F25 exc. M-Sport	11/10-09/14	KIT		303 339 900 113		60	22.0	12.0	100	2400													
		KIT		303 340 900 113		60	23.0	12.0	100	2400	included in the KIT	-09/14		S	CAN	--	E2	D	L1	H	60	B	
BMW X3 F25 exc. M-Sport	10/14-	KIT		303 404 900 113		23.0	12.6	100	2400	included in the KIT	10/14-												
BMW X4 F26	06/14-			303 404 600 001		60	21.0	12.6	100	2400	303 352 300 107												
		KIT		303 404 900 113		23.0	12.6	100	2400	included in the KIT													
BMW X5 E53 No towbar can be mounted on vehicles with US-specification.	06/00-12/06			303 207 600 001		34.0	15.5	150	3500		303 137 300 113	for prepared vehicles		S	FRE	--	E	D	--	H	30	B	
		KIT		303 207 900 113		36.0	15.5	150	3500	included in the KIT		for prepared vehicles		S	FRE	--	E	D	--	H	30	B	
BMW X5 E70 fits X5 M Sport	01/07-			303 368 600 001		26.5	16.0	150	3500		303 368 300 113	12/13-		S	CAN	--	E	D	L1	H	45	B	
											303 451 300 107	-11/13		S	CAN	--	E	--	--	H	45	B	
												303 451 300 113	-11/13		S	CAN	--	E	D	L1	H	45	B

BMW











BMW X5 E70 inc. X5 M-Sport	01/07-11/13	KIT		303 273 900 113		60	31.0	15.5	150	3500		included in the KIT	-11/13	S	CAN	--	E	D	L1	H	45	B
BMW X5 F15	11/13-			303 273 600 001	→ 	60	29.0	15.5	150	3500		303 368 300 113	12/13-	S	CAN	--	E	D	L1	H	45	B
				303 368 600 001			26.5	16.0	150	3500				S	CAN	--	E	D	L1	H	45	B
		KIT		303 368 900 113			90	28.5	16.0	150	3500		included in the KIT	12/13-	S	CAN	--	E	D	L1	H	45
BMW X6 inc. X6M Hybrid models are not permitted to tow by manufacturer. Please order separately cover for bumper cutout at BMW dealers.	05/08-	KIT		303 290 900 113				16.0	140	3500		included in the KIT		S	CAN	--	E	D	L1	H	45	B
BMW X6 inc. X6M Hybrid models are not permitted to tow by manufacturer. Please order separately cover for bumper cutout at BMW dealers.	05/08-12/14			303 290 600 001				16.0	140	3500		303 451 300 107		S	CAN	--	E	--	--	H	45	B
												303 451 300 113		S	CAN	--	E	D	L1	H	45	B
BMW X6 F16	12/14-			303 368 600 001			26.5	16.0	150	3500		303 368 300 113		S	CAN	--	E	D	L1	H	45	B
BMW X6	12/14-	KIT		303 368 900 113		90	28.5	16.0	150	3500		included in the KIT		S	CAN	--	E	D	L1	H	45	B

















Cadillac BLS Station Wagon	12/07-		342 164 600 001	→		90	15.0	9.3	65	1600		300 210 300 107			--	A	--	--	--	--	V		B
			342 165 600 001	→		90	15.0	9.3	65	1600		300 210 300 113			--	A	--	E1	D1	L1	V	90	B
Cadillac CTS exc. Estate / Sport Wagon	08-12/13		342 177 600 001	→		60	27.0	10.2	75	1800		300 210 300 107			--	A	--	--	--	--	V		B
													300 210 300 113			--	A	--	E1	D1	L1	V	90
Cadillac SRX	04-10		342 140 600 001			90	28.0	13.7	100	2500		300 210 300 107			--	A	--	--	--	--	V		B
													300 210 300 113			--	A	--	E1	D1	L1	V	90
Cadillac SRX	10-		342 178 600 001	→		90		11.1	80	2000		300 210 300 107			--	A	--	--	--	--	V		B
													300 210 300 113			--	A	--	E1	D1	L1	V	90

Chevrolet Captiva (S3X)	05/13-	KIT		342 216 900 113		90	21.0	12.3	150	2500	included in the KIT	05/13-	S	A	--	--	D	L1	90	B	
		KIT		342 217 900 113		90	22.5	12.3	150	2500											
Chevrolet Cruze 4 doors Saloon	05/09-			314 373 600 001		60	23.0	9.6	75	1800	314 386 300 107		S	CAN	--	E	--	--	V	90	B
				314 372 600 001		60	23.0	9.6	75	1800	314 386 300 113		S	CAN	--	E	D	L1	V	90	B
		KIT		314 373 900 113		60	25.0	9.6	75	1800	included in the KIT		S	CAN	--	E	D	L1	V	90	B
		KIT		314 372 900 113		60	25.0	9.6	75	1800											
Chevrolet Cruze 5 doors Hatchback	07/11-			314 418 600 001		60	22.0	7.5	75	1200	314 386 300 107		S	CAN	--	E	--	--	V	90	B
				314 416 600 001		60	22.5	7.5	75	1200	314 386 300 113		S	CAN	--	E	D	L1	V	90	B
		KIT		314 418 900 113		60	24.0	7.5	75	1200	included in the KIT		S	CAN	--	E	D	L1	V	90	B
		KIT		314 416 900 113		60	24.5	7.5	75	1200											
Chevrolet Cruze Estate/Station Wagon	06/12-			314 469 600 001		60		9.6	75	1200	314 386 300 107		S	CAN	--	E	--	--	V	90	B
				314 470 600 001		60		9.6	75	1200	314 386 300 113		S	CAN	--	E	D	L1	V	90	B
		KIT		314 469 900 113		60		9.6	75	1200	included in the KIT		S	CAN	--	E	D	L1	V	90	B
		KIT		314 470 900 113		60		9.6	75	1200											































Chrysler 300 C Estate	04-11/11			342 152 600 001		60	21.0	11.0	80	2000		300 210 300 107			--	A	--	--	--	--	V		B
				342 189 600 001		60	21.0	11.0	80	2000		300 210 300 113			--	A	--	E1	D1	L1	V	90	
Chrysler 300 C Saloon	04-11/11			342 152 600 001		60	21.0	11.0	80	2000		300 210 300 107			--	A	--	--	--	--	V		B
				342 189 600 001		60	21.0	11.0	80	2000		300 210 300 113			--	A	--	E1	D1	L1	V	90	
Chrysler 300 C Saloon	11/11-			306 390 600 001	→ 	90	18.0	11.8	80	2000		300 078 300 113			--	FRE	--	--	D1	L1	V		B
				306 391 600 001		90	18.0	11.8	80	2000					--	FRE	--	--	D1	L1	V		B
		KIT KIT		306 390 900 113	→ 	90	20.0	11.8	80	2000		included in the KIT			--	FRE	--	--	D1	L1	V		B
				306 391 900 113		90	20.0	11.8	80	2000					--	FRE	--	--	D1	L1	V		B
Chrysler Grand Voyager exc. mod.05 7 seats Stow 'n Go	04/01-12/07			342 091 600 001		90	21.0	10.0	80	1700		300 065 300 005		for vehicles with earth switched rear fog lights please order separately 2x	--	--	--	E1	--	--	H	15	B
				342 092 600 001	→ 	90	22.5	10.0	80	1700		300 210 300 107			--	A	--	--	--	--	V		B
												300 210 300 113			--	A	--	E1	D1	L1	V	90	
Chrysler Grand Voyager RT	01/08-			342 124 600 001		120	31.0	10.0	85	1700		300 065 300 005		for vehicles with earth switched rear fog lights please order separately 2x	--	--	--	E1	--	--	H	15	B
				342 125 600 001		120	31.0	10.4	85	1700		300 210 300 107			--	A	--	--	--	--	V		B
												300 210 300 113			--	A	--	E1	D1	L1	V	90	
Chrysler PT Cruiser inc. Convertible	00-			342 154 600 001		120	24.0	7.4	80	1200		300 210 300 113			--	A	--	E1	D1	L1	V	90	B
Chrysler Sebring (JR) exc. convertible	01-12/06			342 155 600 001		150	17.0	8.4	80	1500		300 210 300 113			--	A	--	E1	D1	L1	V	90	B

















Chrysler

Chrysler Sebring (JS) exc. convertible	01/07-		342 128 600 001		150	23.0	8.8	85	1500	300 210 300 113					--	A	--	E1	D1	L1	V	90	B		
			342 129 600 001			150	23.0	8.8	85															1500	
Chrysler Voyager exc. mod.05 7 seats Stow 'n Go	04/01-		342 091 600 001		90	21.0	10.0	80	1700	300 065 300 005					--	--	--	E1	--	--	H	15	B		
			342 092 600 001			90	22.5	10.0	80															1700	300 210 300 107
																								300 210 300 113	
Chrysler Voyager Stow 'n Go	02/05-		342 156 600 001		120	31.0	10.2	85	1700	300 065 300 005					--	--	--	E1	--	--	H	15	B		
			342 157 600 001			120	31.0	10.2	85															1700	300 210 300 107
																								300 210 300 113	
Chrysler Ypsilon nur UK	07/11		306 385 600 001		60	19.0	6.1	70	1000	306 383 300 113					S	FRE	--		D1	--	V	105			

























Citröen Berlingo van, minibus Multispace	11/96-04/08			304 054 600 001		90	14.8	7.8	70	1350		304 054 300 113			S	FRE	--	E1	D1	--	V	75	L
		KIT		304 054 900 113		90	16.8	7.8	70	1350		included in the KIT			S	FRE	--	E1	D1	--	V	75	L
Citröen Berlingo First	04/08-			304 054 600 001		90	14.8	7.8	70	1350		304 054 300 113			S	FRE	--	E1	D1	--	V	75	L
Citröen Berlingo First	04/08-11/11	KIT		304 054 900 113		90	16.8	7.8	70	1350		included in the KIT			S	FRE	--	E1	D1	--	V	75	L
Citröen Berlingo L1 short overhang, vehicle length = 4380 mm fits Multispace, inc. Berlingo E- Car	04/08-			304 091 600 001		90	15.0	8.7	64	1600		304 400 300 107	-11/11 OPR 12776	S	CAN	C1	E	--	--	H	105	B	
				304 092 600 001		90	19.0	8.7	64	1600		304 400 300 113		S	CAN	C1	E	D	L1	H	105	B	
												304 402 300 107	11/11- OPR 12775	S	CAN	C1	E	--	--	V	105	B	
												304 402 300 113	11/11- OPR 12775	S	CAN	C1	E	D	L1	V	105	B	
Citröen Berlingo L1 short overhang, vehicle length = 4380 mm fits Multispace, inc. Berlingo E- Car	04/08-11/11	KIT		304 091 900 113		90	17.0	8.7	64	1600		included in the KIT			S	CAN	C1	E	D	L1	H	105	B
		KIT		304 092 900 113		90	21.0	8.7	64	1600													
Citröen Berlingo L2 long overhang, vehicle length = 4628 mm	04/08-			304 129 600 001		90	16.3	8.7	64	1600		304 400 300 107	-11/11 OPR 12776	S	CAN	C1	E	--	--	H	105	B	
				304 131 600 001		90	19.0	8.7	64	1600		304 400 300 113		S	CAN	C1	E	D	L1	H	105	B	
												304 402 300 107	11/11- OPR 12775	S	CAN	C1	E	--	--	V	105	B	
												304 402 300 113	11/11- OPR 12775	S	CAN	C1	E	D	L1	V	105	B	
Citröen Berlingo L2 long overhang, vehicle length = 4628 mm	04/08-11/11	KIT		304 129 900 113		90	18.3	8.7	64	1600		included in the KIT			S	CAN	C1	E	D	L1	H	105	B
		KIT		304 131 900 113		90	21.0	8.7	64	1600													



















Citroën









Citroën C Crosser	09/07-			340 094 600 001		90	27.0	10.9	100	2000		340 075 300 113			S	FRE	--	E	D	L	H	75	B
		KIT		340 094 900 113		90	29.0	10.9	100	2000		included in the KIT			S	FRE	--	E	D	L	H	75	B
Citroën C2	03-			304 110 600 001			18.0	4.0	25	565		300 072 300 107	-09/05	--	FRE	--	--	--	--	V			B
				304 111 600 001				19.0	4.0	25	565		304 402 300 107	09/05-	S	CAN	C1	E	--	--	V	105	B
				304 111 600 001				19.0	4.0	25	565		304 402 300 113	09/05-	S	CAN	C1	E	D	L1	V	105	B
				304 111 600 001				19.0	4.0	25	565		300 072 300 113	-09/05	--	FRE	--	--	D1	L1	V		
Citroën C3	05/02-11/09			304 074 600 001		120	16.0	6.6	50	1100		300 072 300 107	-09/05	--	FRE	--	--	--	--	V			B
				304 074 600 001		120	16.0	6.6	50	1100		300 072 300 113	-09/05	--	FRE	--	--	D1	L1	V			B
				304 109 600 001				23.0	6.5	48	1176		304 402 300 107	09/05-	S	CAN	C1	E	--	--	V	105	B
				304 109 600 001				23.0	6.5	48	1176		304 402 300 113	09/05-	S	CAN	C1	E	D	L1	V	105	B
Citroën C3 exc. vehicles with park distance control	01/10-			304 136 600 001		60	15.1	6.9	54	1225		304 402 300 107	09/05-	S	CAN	C1	E	--	--	V	105	B	
		KIT		304 136 900 113		60	17.0	6.9	54	1225		included in the KIT			S	CAN	C1	E	D	L1	V	105	B
Citroën C3	01/10-			304 137 600 001		60	16.4	6.9	54	1225		304 402 300 107	09/05-	S	CAN	C1	E	--	--	V	105	B	
		KIT		304 137 900 113		60	18.4	6.9	54	1225		included in the KIT			S	CAN	C1	E	D	L1	V	105	B
Citroën C3 Picasso	03/09-			304 127 600 001		60	15.2	7.3	61	1200		304 402 300 107			S	CAN	C1	E	--	--	V	105	B
				304 139 600 001		60	15.2	7.3	61	1200		304 402 300 113			S	CAN	C1	E	D	L1	V	105	B
		KIT		304 127 900 113		60	17.2	7.3	61	1200		included in the KIT			S	CAN	C1	E	D	L1	V	105	B
		KIT		304 139 900 113		60	17.2	7.3	61	1200		included in the KIT			S	CAN	C1	E	D	L1	V	105	B

Citröen C3 Pluriel	03/03-		304 076 600 001			120	16.0	5.2	60	800		300 072 300 107	-09/05	--	FRE	--	--	--	--	V		B							
Citröen C3 X-TR 3 / 5 doors	05/02-		304 074 600 001			120	16.0	6.6	50	1100		300 072 300 107	-09/05	--	FRE	--	--	--	--	V		B							
Citröen C4 Aircross	03/12-		340 092 600 001			90	22.0	8.5	70	1400		340 093 300 113																	
		KIT		340 092 900 113			90	24.0	8.5	70	1400		included in the KIT																
KIT		340 093 900 113			90	26.0	8.5	70	1400																				
Citröen C4 Cactus	09/14-		304 159 600 001			17.0	5.2	55	780		315 185 300 107			S	CAN	C	E					B							
Citröen C4 Coupé fits hatchback, VTR, VTR Plus and VTS	11/04-10/10		315 108 600 001			60	19.0	9.1	80	1700		300 210 300 107	-01/07	--	A	--	--	--	--	V		B							
			315 109 600 001			60	21.0	9.1	80	1700		300 210 300 113	-01/07	--	A	--	E1	D1	L1	V	90	B							
Citröen C4 Grand Picasso	11/06-01/11	KIT				60	24.0	9.7	75	1700		included in the KIT																	
		KIT				60	24.7	9.7	80	1700			-01/11 OPR < 12531	S	CAN	C1	E	D	L1	H	105	B							







Citroën



















Citroën C5 Saloon	05/08-			304 145 600 001		120	24.5	10.4	80	1900		304 400 300 107			S	CAN	C1	E	--	--	H	105	B		
												304 400 300 113			S	CAN	C1	E	D	L1	H	105	B		
		KIT		304 145 900 113		120	26.5	10.4	80	1900		included in the KIT			S	CAN	C1	E	D	L1	H	105	B		
Citroën C5 Saloon	05/08-			304 146 600 001		120	22.0	10.4	80	1900		304 400 300 107			S	CAN	C1	E	--	--	H	105	B		
												304 400 300 113			S	CAN	C1	E	D	L1	H	105	B		
		KIT		304 146 900 113		120	24.0	10.4	80	1900		included in the KIT			S	CAN	C1	E	D	L1	H	105	B		
Citroën C8	09/02-			315 098 600 001		75	19.8	10.8	100	1900		304 400 300 107		10/05-	S	CAN	C1	E	--	--	H	105	B		
												304 400 300 113			S	CAN	C1	E	D	L1	H	105	B		
						315 097 600 001		75	22.0	10.8	100	1900		315 097 300 107	→	-09/05	S	FRE	--	E	--	--	H	45	B
													315 097 300 113	→	-09/05	S	FRE	--	E	D1	L1	H	45	B	
Citroën C8	10/05-	KIT		315 098 900 113		75	21.8	10.8	100	1900															
		KIT		315 097 900 113		75	24.0	10.8	100	1900		included in the KIT			S	CAN	C1	E	D	L1	H	105	B		
Citroën DS3 exc. vehicles with park distance control	01/10-			304 136 600 001		60	15.1	6.9	54	1225		304 402 300 107			S	CAN	C1	E	--	--	V	105	B		
												304 402 300 113			S	CAN	C1	E	D	L1	V	105	B		
		KIT		304 136 900 113		60	17.0	6.9	54	1225		included in the KIT			S	CAN	C1	E	D	L1	V	105	B		
Citroën DS3	01/10-			304 137 600 001		60	16.4	6.9	54	1225		304 402 300 107			S	CAN	C1	E	--	--	V	105	B		
												304 402 300 113			S	CAN	C1	E	D	L1	V	105	B		
		KIT		304 137 900 113		60	18.4	6.9	54	1225		included in the KIT			S	CAN	C1	E	D	L1	V	105	B		

Citroën DS3 Convertible exc. vehicles with park distance control	03/13-			304 136 600 001		60	15.1	6.9	54	1225		304 402 300 107			S	CAN	C1	E	--	--	V	105	B
												304 402 300 113			S	CAN	C1	E	D	L1	V	105	B
		KIT		304 136 900 113		60	17.0	6.9	54	1225		included in the KIT			S	CAN	C1	E	D	L1	V	105	B
Citroën DS3 Convertible	03/13			304 137 600 001		60	16.4	6.9	54	1225		304 402 300 107			S	CAN	C1	E	--	--	V	105	B
												304 402 300 113			S	CAN	C1	E	D	L1	V	105	B
Citroën DS3 Convertible	03/13-	KIT		304 137 900 113		60	18.4	6.9	54	1225		included in the KIT			S	CAN	C1	E	D	L1	V	105	B
Citroën DS4	04/11-			304 147 600 001		60	17.4	9.2	75	1550		304 144 300 113			S	CAN	C	E	D	L	V	90	B
				304 148 600 001		60	19.0	9.2	75	1550						S	CAN	C	E	D	L	V	90
		KIT		304 147 900 113		60	19.4	9.2	75	1550		included in the KIT			S	CAN	C	E	D	L	V	90	B
		KIT		304 148 900 113		60	21.0	9.2	75	1550						S	CAN	C	E	D	L	V	90
Citroën DS5	02/12-			304 149 600 001		120	29.0	8.5	75	1500		304 144 300 113			S	CAN	C	E	D	L	V	90	B
Citroën Evasion / Synergie	09/94-08/02			315 072 600 001		60	16.4	10.9	100	2000		300 060 300 107			--	C2	--	E1	--	--	H	45	B
												300 060 300 113			--	C2	--	E1	D1	L1	H	45	B





<p>Citroën Jumper / Relay Van For vehicles with long superstructure L4/XL please order separately a set distance tubes to strengthen the framework, no. 906270650003. Some vehicles 03/08- do not have chassis bores. In this case it is necessary to bore them subsequent. For the mounting time will last 120 min. longer.</p>	02/11-	KIT		306 272 900 113		60	34.0	16.9	150	3000				included in the KIT	02/11- from chassis no. 1948841	S	FRE	--	E	D1	L1	V	105	B
<p>Citroën Jumper / Relay Van inc. towball For vehicles with long superstructure L4/XL please order separately a set distance tubes to strengthen the framework, no. 906270650003. Some vehicles 03/08- do not have chassis bores. In this case it is necessary to bore them subsequent. For the mounting time will last 120 min. longer.</p>	06/06-			306 357 600 001		60	21.0	15.8	150	3000		306 271 300 107	02/11- from chassis no. 1948841	S	FRE	--	E	--	--	V	105	B		
												306 271 300 113	02/11- from chassis no. 1948841	S	FRE	--	E	D1	L1	V	105	B		
												306 510 300 107	-02/11 chassis no. 1948840	S	FRE	--	E	--	--	V	105	B		
												306 510 300 113	-02/11 chassis no. 1948840	S	FRE	--	E	D1	L1	V	105	B		
<p>Citroën Jumper / Relay Van inc. towball 329059600001 For vehicles with long superstructure L4/XL please order separately a set distance tubes to strengthen the framework, no. 906270650003. Some vehicles 03/08- do not have chassis bores. In this case it is necessary to bore them subsequent. For the mounting time will last 120 min. longer.</p>	06/06-			306 330 600 001		60	32.0	16.9	150	3000		306 271 300 107	02/11- from chassis no. 1948841	S	FRE	--	E	--	--	V	105	B		
												306 271 300 113	02/11- from chassis no. 1948841	S	FRE	--	E	D1	L1	V	105	B		
												306 510 300 107	-02/11 chassis no. 1948840	S	FRE	--	E	--	--	V	105	B		
												306 510 300 113	-02/11 chassis no. 1948840	S	FRE	--	E	D1	L1	V	105	B		
<p>Citroën Jumper / Relay Van inc. towball 329059600001 For vehicles with long superstructure L4/XL please order separately a set distance tubes to strengthen the framework, no. 906270650003. Some vehicles 03/08- do not have chassis bores. In this case it is necessary to bore them subsequent. For the mounting time will last 120 min. longer.</p>	06/06-02/11	KIT		306 330 900 113		60	34.0	16.9	150	3000			included in the KIT	-02/11 chassis no. 1948840	S	FRE	--	E	D1	L1	V	105	B	





















Citroën

Citroën Jumper / Relay Van inc. towball 329059600001 For vehicles with long superstructure L4/XL please order separately a set distance tubes to strengthen the framework, no. 906270650003. Some vehicles 03/08- do not have chassis bores. In this case it is necessary to bore them subsequent. For the mounting time will last 120 min. longer.	02/11-	KIT		306 357 900 113		60	34.0	16.9	150	3000		included in the KIT	02/11- from chassis no. 1948841	S	FRE	--	E	D1	L1	V	105	B
Citroën Jumper / Relay Chassis Cab inc. 4 WD exc. vehicles with gas bottle instead of the spare wheel 4 WD: bolt kit (order no. 906216650002) must be ordered separately. inc. vehicles until 10/95: body reinforcement kit: 306142650002 must be ordered separately. Towball for vehicles with standard chassis: 329089600001. Towball for vehicles with 16" wheels and reinforced springs: 329062600001. When mounting swap system to vehicles with standard chassis we recommend towball: 329059600001	03/94-06/06			306 216 600 001		60	32.7	13.3	150	2500		300 052 300 107	03/02-	--	FRE	--	E1	--	--	V		B
												300 052 300 113	03/02-	--	FRE	--	E1	D1	--	V		B
												300 060 300 113	-03/02	--	C2	--	E1	D1	L1	H	45	B
Citroën Jumper / Relay Chassis Cab inc. towball 329059600001. For vehicles with long superstructure L4/XL please order separately a set distance tubes to strengthen the framework, no. 906270650003.	06/06-			306 318 600 001		60	30.5	15.9	150	3000		306 531 300 107		S	FRE	--	E1	--	--	V	90	L
												306 531 300 113		S	FRE	--	E1	D	--	V	90	L
Citroën Jumper / Relay Chassis Cab inc. towball For vehicles with long superstructure L4/XL please order separately a set distance tubes to strengthen the framework, no. 906270650003.	06/06-	KIT		306 318 900 113		60	32.5	15.9	150	3000		included in the KIT		S	FRE	--	E1	D	--	V	90	L
												306 357 600 001		60	21.0	15.8	150	3000		306 531 300 107		S
												306 531 300 113		S	FRE	--	E1	D	--	V	90	L

















Citroën Jumper / Relay Chassis Cab combined universal HGV towbar for towballs and coupling bolt inc. towball 329059600001. For vehicles with long superstructure L4/XL please order separately a set distance tubes to strengthen the framework, order no. 906270650003. Please order separately coupling bolt 342090600001.	06/06-		306 359 600 001			90	40.0	12.5	150	2000		306 531 300 107			S	FRE	--	E1	--	--	V	90	L						
												306 531 300 113			S	FRE	--	E1	D	--	V	90	L						
Citroën Jumper / Relay Motor homes no towbar offered	06/06-											306 531 300 183			S	FRE	--	E1	D	L1	V	105	B						
Citroën Jumpy / Dispatch	09/94-01/07		315 072 600 001	→ 		60	16.4	10.9	100	2000		300 060 300 107	-07/97	--	C2	--	E1	--	--	H	45	B							
												300 060 300 113	-07/97	--	C2	--	E1	D1	L1	H	45	B							
												306 155 300 113	08/97-	S	C2	--	E1	D	--	H	45	L							
Citroën Jumpy / Dispatch	01/07-		306 331 600 001			75	22.5	12.2	122	2200		304 400 300 107			S	CAN	C1	E	--	--	H	105	B						
			306 333 600 001												75	22.5	12.2	122	2200	304 400 300 113	S	CAN	C1	E	D	L1	H	105	B
		KIT		306 331 900 113		75	22.5	12.2	122	2200	included in the KIT			S	CAN	C1	E	D	L1	H	105	B							
		KIT		306 333 900 113		75	24.5	12.2	122	2200																			
Citroën Nemo exc. vehicles with gas drive	02/08-		306 349 600 001			150	16.5	7.5	75	1300		306 580 300 107			S	FRE	--	E	--	--	V	120	B						
			306 351 600 001												150	17.0	7.5	75	1300	306 580 300 113	S	FRE	--	E	D1	L1	V	120	B
			306 350 600 001												150	17.0	7.5	75	1300										
		KIT		306 349 900 113		150	18.5	7.5	75	1300	included in the KIT			S	FRE	--	E	D1	L1	V	120	B							
		KIT		306 350 900 113		150	19.0	7.5	75	1300																			















Citroën

Citroën Xsara Picasso inc. facelift from 04/2004	09/99-		304 069 600 001			90	16.0	7.5	90	1300		304 064 300 107			S	FRE	--	--	--	--	H	45	B
																			S	FRE	--	--	D1
Citroën Xsara Picasso	09/99-03/04		304 068 600 001	→		120	17.5	7.5	90	1300		304 064 300 107			S	FRE	--	--	--	--	H	45	B
																			S	FRE	--	--	D1
Citroën Xsara Picasso	04/04-		304 079 600 001			120	18.0	7.5	90	1300		304 064 300 107			S	FRE	--	--	--	--	H	45	B
																			S	FRE	--	--	D1

















Dacia Dokker X67	11/12-		316 333 600 001			60	19.5	7.3	75	1200		316 333 300 107			S	A	--	--	--	--	V	75	B
			316 334 600 001			60	19.5	7.3	75	1200		316 333 300 113			S	A	--	--	D1	L1	V	75	B
	KIT		316 333 900 113			60	21.5	7.3	75	1200		included in the KIT			S	A	--	--	D1	L1	V	75	B
			316 334 900 113			60	21.5	7.3	75	1200						S	A	--	--	D1	L1	V	75
Dacia Dokker Express	11/12-		316 333 600 001			60	19.5	7.3	75	1200		300 210 300 107			--	A	--	--	--	--	V		B
			316 334 600 001			60	19.5	7.3	75	1200		316 334 300 113			S	A	--	--	D1	--		60	B
Dacia Duster I+II, SUV 4x2, 4x4	03/10-		316 365 600 001			60	16.5	8.6	75	1600		316 315 300 113			S	FRE	--	E1	D1	L1	H	45	L
			316 366 600 001			60	18.5	8.6	75	1600						S	FRE	--	E1	D1	L1	H	45
	KIT		316 314 900 113			120	17.0	8.3	75	1500		included in the KIT			S	FRE	--	E1	D1	L1	H	45	L
			316 315 900 113			120	21.0	8.3	75	1500						S	FRE	--	E1	D1	L1	H	45
Dacia Duster I, SUV 4x2 + 4x4 exc. Duster II	03/10-		316 314 600 001			120	15.0	8.3	75	1500		316 315 300 113			S	FRE	--	E1	D1	L1	H	45	L
			316 315 600 001			120	19.0	8.3	75	1500						S	FRE	--	E1	D1	L1	H	45
Dacia Lodgy, J 92 5 seats	06/12-		316 321 600 001			45	19.0	8.1	75	1400		316 321 300 113			S	A	--	--	D1	--	V	90	B
		KIT		316 321 900 113			45	21.0	8.1	75	1400		included in the KIT			S	A	--	--	D1	--	V	90







Dacia

Dacia Lodgy, J 92 5/7 seats	06/12-		316 324 600 001			45	19.5	8.1	75	1400		316 321 300 113			S	A	--	--	D1	--	V	90	B	
		KIT		316 324 900 113			45	21.5	8.1	75	1400		included in the KIT			S	A	--	--	D1	--	V	90	B
Dacia Lodgy, J 92 7 seats	06/12-		316 345 600 001			45	19.0	8.1	75	1400		316 321 300 113			S	A	--	--	D1	--	V	90	B	
		KIT		316 345 900 113			45	21.0	8.1	75	1400		included in the KIT			S	A	--	--	D1	--	V	90	B
Dacia Logan Estate exc. vehicles with gas drive	01/07-06/13		316 259 600 001			60	22.6	7.7	75	1300		300 072 300 107	-12/07		--	FRE	--	--	--	--	V		B	
			316 307 600 001			60	23.0	7.7	75	1300		300 072 300 113	-12/07		--	FRE	--	--	D1	L1	V		B	
			316 307 600 001			60	23.0	7.7	75	1300		316 259 300 113	01/08-		S	C2	--	E1	D1	L1	V	45	L	
Dacia Logan Estate exc. vehicles with gas drive	01/08-06/13	KIT		316 259 900 113			60	24.6	7.7	75	1300		included in the KIT	01/08-	S	C2	--	E1	D1	L1	V	45	L	
Dacia Logan Saloon Phase I + II	05-		316 285 600 001			120	21.0	6.4	75	1100		300 072 300 107			--	FRE	--	--	--	--	V		B	
			316 285 600 001			120	21.0	6.4	75	1100		300 072 300 113			--	FRE	--	--	D1	L1	V		B	
Dacia Logan MCV/ Estate	07/13-		316 341 600 001			90	15.0	6.8	75	1150		316 338 300 107			S	A	--	--	--	--		60	B	
			316 342 600 001			90	18.0	6.8	75	1150		316 338 300 113			S	A	--	--	D1	L1		60	B	
		KIT		316 341 900 113			90	16.0	6.8	75	1150					S	A	--	--	D1	L1		60	B
		KIT		316 342 900 113			90	19.0	6.8	75	1150		included in the KIT			S	A	--	--	D1	L1		60	B
Dacia Logan Pick-up	03/09-		316 307 600 001			60	23.0	7.7	75	1300		300 052 300 107			--	FRE	--	E1	--	--	V		B	
			316 307 600 001			60	23.0	7.7	75	1300		300 052 300 113			--	FRE	--	E1	D1	--	V		B	

















Dacia Logan Symbol Saloon L52	01/13-		316 343 600 001		90	14.0	6.5	75	1100	316 340 300 113			S	A	--	--	D1	L1			60	B	
			316 344 600 001		90	16.0	6.5	75	1100														
	KIT		316 343 900 113		90	15.0	6.5	75	1100	included in the KIT			S	A	--	--	D1	L1			60	B	
			316 344 900 113		90	17.0	6.5	75	1100														
Dacia Logan Van Express exc. vehicles with gas drive	03/09-		316 259 600 001		60	22.6	7.7	75	1300	316 259 300 113			S	C2	--	E1	D1	L1	V		45	L	
			316 307 600 001		60	23.0	7.7	75	1300														
	KIT		316 259 900 113		60	24.6	7.7	75	1300	included in the KIT			S	C2	--	E1	D1	L1	V		45	L	
Dacia Sandero inc. Stepway, exc. GPL	06/08-01/13		316 286 600 001		60	15.5	7.3	75	1355	316 442 300 107			S	FRE	--	E1	--	--	H		45	L	
			316 287 600 001		60	16.5	7.3	75	1355	316 442 300 113			S	FRE	--	E1	D1	L1	H		45	L	
		KIT		316 286 900 113		60	17.5	7.3	75	1355	included in the KIT			S	FRE	--	E1	D1	L1	H		45	L
			316 287 900 113		60	18.5	7.3	75	1355														

























Dacia







Dacia Sandero B52	01/13-		316 343 600 001		90	14.0	6.5	75	1100	316 340 300 107	S								
			316 344 600 001		90	16.0	6.5	75	1100	316 340 300 113	S	A	--	--	D1	L1	60	B	
	KIT		316 343 900 113		90	15.0	6.5	75	1100	included in the KIT	S	A	--	--	D1	L1	60	B	
			316 344 900 113		90	17.0	6.5	75	1100										
Dacia Sandero Stepway	01/13-		316 343 600 001		90	14.0	6.5	75	1100	316 340 300 113	S	A	--	--	D1	L1	60	B	
			316 344 600 001		90	16.0	6.5	75	1100										
	KIT		316 343 900 113		90	15.0	6.5	75	1100	included in the KIT	S	A	--	--	D1	L1	60	B	
			316 344 900 113		90	17.0	6.5	75	1100										

Daihatsu Charade	05/11-			335 350 600 001			60	17.0	6.8	75	1200		335 383 300 107			S	FRE	--	--	--	--	V	120	B
				335 383 600 001			75	18.7	6.8	50	1200		335 383 300 113			S	FRE	--	--	D1	L1	V	120	B
		KIT		335 383 900 113			75	20.7	6.8	50	1200		included in the KIT			S	FRE	--	--	D1	L1	V	120	B
Daihatsu Terios	06/06-			342 107 600 001			90	35.0	7.6	55	1350		300 072 300 107			--	FRE	--	--	--	--	V		B
													300 072 300 113			--	FRE	--	--	D1	L1	V		B









Dodge









Dodge Avenger	01/07-		342 128 600 001		150	23.0	8.8	85	1500	300 210 300 107	--	A	--	--	--	--	V	B
				342 129 600 001		150	23.0	8.8	85	1500	300 210 300 113	--	A	--	E1	D1	L1	V
Dodge Caliber	06-		342 158 600 001		60	18.0	8.3	75	1400	300 210 300 107	--	A	--	--	--	--	V	B
				342 159 600 001		60	18.0	8.3	75	1400	300 210 300 113	--	A	--	E1	D1	L1	V
Dodge Journey, JC 49	08-		342 135 600 001		75	13.3	9.6	80	1600	300 210 300 107	--	A	--	--	--	--	V	B
				342 136 600 001		75	15.8	9.6	80	1600	300 210 300 113	--	A	--	E1	D1	L1	V
Dodge Magnum	01/07-		342 152 600 001		60	21.0	11.0	80	2000	300 210 300 107	--	A	--	--	--	--	V	B
				342 189 600 001		60	21.0	11.0	80	2000	300 210 300 113	--	A	--	E1	D1	L1	V
Dodge Nitro exc. vehicles with 20" spare wheel	07-		342 142 600 001		45	35.0	15.3	140	3500	300 210 300 107	--	A	--	--	--	--	V	B
											300 210 300 113	--	A	--	E1	D1	L1	V
Dodge Nitro fits SXT with 20" spare wheel but not SRT	03/08-		342 131 600 001		90	30.0	15.3	140	3500	300 210 300 107	--	A	--	--	--	--	V	B
											300 210 300 113	--	A	--	E1	D1	L1	V

Fiat 500 inc. Convertible exc. Abarth - 135 HP	07/07-			306 311 600 001		90	14.0	5.1	60	800		306 560 300 113			S	FRE	--	E	D1	--	V	120	L	
Fiat 500 L inc. Trekking and Living	10/12-			306 401 600 001		60	18.0	7.5	90	1200		306 397 300 107			S	FRE	--	E	--	--	V	120		
				306 400 600 001		60	21.0	7.5	90	1200		306 397 300 113			S	FRE	--	E	D1	L1	V	120		
		KIT		306 401 900 113		60	20.0	7.5	90	1200		included in the KIT			S	FRE	--	E	D1	L1	V	120		
		KIT		306 400 900 113		60	23.0	7.5	90	1200						S	FRE	--	E	D1	L1	V	120	
Fiat 500 X inc. Cross	02/15-			342 196 600 001		90	20.0	8.7	100	1500		306 441 300 113												
				342 197 600 001		90	21.0	8.7	100	1500														
		KIT		306 196 900 113		90	22.0	8.7	100	1500		included in the KIT												
		KIT		306 197 900 113		90	23.0	8.7	100	1500														
Fiat Bravo	04/07-			306 366 600 001		60	18.0	7.9	60	1350		306 550 300 113			S	FRE	--	E	D1	L1	V	105	L	
				306 286 600 001		60	21.0	7.9	60	1350														
		KIT		306 286 900 113		60	23.0	7.9	60	1350		included in the KIT			S	FRE	--	E	D1	L1	V	105	L	
Fiat Croma	06/05-			306 265 600 001	→ 	120	24.0	9.5	100	1700		306 265 300 107	→		S	FRE	--	E	--	--	V	90	B	
												306 265 300 113	→		S	FRE	--	E	D1	L1	V	90	B	













Fiat Doblo Cargo WorkUP Pick up	08/11-			306 393 600 001			90	31.0	9.3	100	1500		306 392 300 113			S	FRE	--	E1	D1	--	V	90	B
Fiat Ducato Van inc. 4 WD exc. vehicles with gas bottle instead of the spare wheel 4 WD: bolt kit (order no. 906216650002) must be ordered separately. inc. vehicles until 10/95: body reinforcement kit: 306142650002 must be ordered separately. Towball for vehicles with standard chassis: 329089600001. Towball for vehicles with 16" wheels and reinforced springs: 329062600001. When mounting swap system to vehicles with standard chassis we recommend towball: 329059600001	04/94-06/06			306 216 600 001			60	32.7	13.3	150	2500		306 142 300 113	→	-03/02	S	C2	--	E1	D1	L1	H	45	L
													306 216 300 113		03/02-	S	FRE	--	E	D1	L1	V	75	B
Fiat Ducato Van inc. towball	08/99-06/06			306 329 600 001				29.0	12.5	130	2000		306 142 300 113	→	-03/02	S	C2	--	E1	D1	L1	H	45	L
													306 216 300 113		03/02-	S	FRE	--	E	D1	L1	V	75	B
Fiat Ducato Van For vehicles with long superstructure L4/XL please order separately a set distance tubes to strengthen the framework, no. 906270650003. Some vehicles 03/08- do not have chassis bores. In this case it is necessary to bore them subsequent. For the mounting time will last 120 min. longer.	06/06-			306 271 600 001			60	32.0	16.9	150	3000		306 271 300 107		02/11- from chassis no. 1948841	S	FRE	--	E	--	--	V	105	B
													306 271 300 113		02/11- from chassis no. 1948841	S	FRE	--	E	D1	L1	V	105	B
													306 510 300 107		-02/11 chassis no. 1948840	S	FRE	--	E	--	--	V	105	B
													306 510 300 113		-02/11 chassis no. 1948840	S	FRE	--	E	D1	L1	V	105	B
Fiat Ducato Van For vehicles with long superstructure L4/XL please order separately a set distance tubes to strengthen the framework, no. 906270650003. Some vehicles 03/08- do not have chassis bores. In this case it is necessary to bore them subsequent. For the mounting time will last 120 min. longer.	06/06-02/11	KIT		306 271 900 113			60	34.0	16.9	150	3000				-02/11 chassis no. 1948840	S	FRE	--	E	D1	L1	V	105	B
													included in the KIT											

















Fiat

Fiat Ducato Van For vehicles with long superstructure L4/XL please order separately a set distance tubes to strengthen the framework, no. 906270650003. Some vehicles 03/08- do not have chassis bores. In this case it is necessary to bore them subsequent. For the mounting time will last 120 min. longer.	02/11-	KIT		306 272 900 113		60	34.0	16.9	150	3000				included in the KIT		02/11- from chassis no. 1948841	S	FRE	--	E	D1	L1	V	105	B
Fiat Ducato Van inc. towball For vehicles with long superstructure L4/XL please order separately a set distance tubes to strengthen the framework, no. 906270650003. Some vehicles 03/08- do not have chassis bores. In this case it is necessary to bore them subsequent. For the mounting time will last 120 min. longer.	06/06-			306 357 600 001		60	21.0	15.8	150	3000		306 271 300 107	02/11- from chassis no. 1948841	S	FRE	--	E	--	--	V	105	B			
												306 271 300 113	02/11- from chassis no. 1948841	S	FRE	--	E	D1	L1	V	105	B			
												306 510 300 107	-02/11 chassis no. 1948840	S	FRE	--	E	--	--	V	105	B			
												306 510 300 113	-02/11 chassis no. 1948840	S	FRE	--	E	D1	L1	V	105	B			
Fiat Ducato Van inc. towball 329059600001 For vehicles with long superstructure L4/XL please order separately a set distance tubes to strengthen the framework, no. 906270650003. Some vehicles 03/08- do not have chassis bores. In this case it is necessary to bore them subsequent. For the mounting time will last 120 min. longer.	06/06-			306 330 600 001		60	32.0	16.9	150	3000		306 271 300 107	02/11- from chassis no. 1948841	S	FRE	--	E	--	--	V	105	B			
												306 271 300 113	02/11- from chassis no. 1948841	S	FRE	--	E	D1	L1	V	105	B			
												306 510 300 107	-02/11 chassis no. 1948840	S	FRE	--	E	--	--	V	105	B			
												306 510 300 113	-02/11 chassis no. 1948840	S	FRE	--	E	D1	L1	V	105	B			
Fiat Ducato Van inc. towball 329059600001 For vehicles with long superstructure L4/XL please order separately a set distance tubes to strengthen the framework, no. 906270650003. Some vehicles 03/08- do not have chassis bores. In this case it is necessary to bore them subsequent. For the mounting time will last 120 min. longer.	06/06-02/11	KIT		306 330 900 113		60	34.0	16.9	150	3000			included in the KIT		-02/11 chassis no. 1948840	S	FRE	--	E	D1	L1	V	105	B	





















Fiat Ducato Van inc. towball 329059600001 For vehicles with long superstructure L4/XL please order separately a set distance tubes to strengthen the framework, no. 906270650003. Some vehicles 03/08- do not have chassis bores. In this case it is necessary to bore them subsequent. For the mounting time will last 120 min. longer.	02/11-	KIT		306 357 900 113		60	34.0	16.9	150	3000		included in the KIT			S	FRE	--	E1	D	--	V	90	L	
Fiat Ducato Chassis Cab inc. 4 WD exc. vehicles with gas bottle instead of the spare wheel 4 WD: bolt kit (order no. 906216650002) must be ordered separately. Towball for vehicles with standard chassis: 329089600001 (not included). Towball for vehicles with 16" wheels and reinforced springs: 329062600001 (not included). When mounting swap system to vehicles with standard chassis we recommend towball 329059600001 (not included).	04/94-06/06			306 216 600 001		60	32.7	13.3	150	2500		300 052 300 107	03/02-	--	FRE	--	E1	--	--	V			B	
													300 052 300 113	03/02-	--	FRE	--	E1	D1	--	V			B
														300 060 300 113	03/02-	--	C2	--	E1	D1	L1	H	45	B
Fiat Ducato Chassis Cab inc. towball	08/99-06/06			306 329 600 001			29.0	12.5	130	2000		300 052 300 107	03/02-	--	FRE	--	E1	--	--	V			B	
													300 052 300 113	03/02-	--	FRE	--	E1	D1	--	V			B
														300 060 300 113	03/02-	--	C2	--	E1	D1	L1	H	45	B
Fiat Ducato Chassis Cab inc. towball 329059600001. For vehicles with long superstructure L4/XL please order separately a set distance tubes to strengthen the framework, no. 906270650003.	06/06-			306 318 600 001		60	30.5	15.9	150	3000		306 531 300 107		S	FRE	--	E1	--	--	V	90	L		
		KIT		306 318 900 113		60	32.5	15.9	150	3000		included in the KIT		S	FRE	--	E1	D	--	V	90	L		
Fiat Ducato Chassis Cab inc. towball For vehicles with long superstructure L4/XL please order separately a set distance tubes to strengthen the framework, no. 906270650003.	06/06-			306 357 600 001		60	21.0	15.8	150	3000		306 531 300 107		S	FRE	--	E1	--	--	V	90	L		
													306 531 300 113		S	FRE	--	E1	D	--	V	90	L	





























Fiat

Fiat Ducato Chassis Cab combined universal HGV towbar for towballs and coupling bolt inc. towball 329059600001. For vehicles with long superstructure L4/XL please order separately a set distance tubes to strengthen the framework, order no. 906270650003. Please order separately coupling bolt 342090600001. After mounting the towbar license plate must be dislocated.	06/06-		306 359 600 001			90	40.0	12.5	150	2000		306 531 300 107			S	FRE	--	E1	--	--	V	90	L	
			306 531 300 113			S	FRE	--	E1	D		--			V	90	L							
Fiat Fiorino Van / Qubo exc. vehicles with gas drive	02/08-		306 349 600 001			150	16.5	7.5	75	1300		306 580 300 107			S	FRE	--	E	--	--	V	120	B	
			306 351 600 001			306 580 300 113	S	FRE	--	E		D1			L1	V	120	B						
			306 350 600 001			306 580 300 113	S	FRE	--	E		D1			L1	V	120	B						
		KIT	306 349 900 113			150	18.5	7.5	75	1300	included in the KIT			S	FRE	--	E	D1	L1	V	120	B		
		KIT	306 350 900 113			150	19.0	7.5	75	1300														
Fiat Freemont exc. Freemont Cross	09/11-		342 135 600 001			75	13.3	9.6	80	1600		300 078 300 113			--	FRE	--	--	D1	L1	V		B	
			342 136 600 001			75	15.8	9.6	80	1600														
Fiat Grande Punto	10/05-10/09		306 375 600 001			90	19.0	6.7	75	1100		306 252 300 113			S	FRE	--	E	D1	L1	V	105	B	
			306 374 600 001			90	19.0	6.7	75	1100														
Fiat Idea	01/04-08		306 253 600 001			180	18.0	6.8	80	1200		306 240 300 113				S	FRE	--	E	D1	L1	H	45	B
			306 353 600 001			180	18.0	6.8	80	1200														

























Fiat Linea	06/07-		306 323 600 001	→		120	22.5	6.9	70	1200	300 078 300 113			--	FRE	--	--	D1	L1	V		B	
			306 570 300 113	→											S	FRE	--	E	D1	L1	V	120	B
Fiat Marea Weekend estate	09/96-		306 217 600 001	→		>150	28.2	9.3	70	1800	300 060 300 107	-11/99 chassis no. 2032671		--	C2	--	E1	--	--	H	45	B	
			306 060 300 113										-11/99 chassis no. 2032671		--	C2	--	E1	D1	L1	H	45	B
Fiat Multipla inc. vehicles with gas drive	11/98-		306 227 600 001	→		>150	22.7	8.4	90	1500	300 072 300 107	-08/04		--	FRE	--	--	--	--	V		B	
			300 072 300 113										-08/04		--	FRE	--	--	D1	L1	V		B
			306 227 300 107	→											S	FRE	--	E	--	--	V	90	L
			306 227 300 113	→											S	FRE	--	E	D1	L1	V	90	L
Fiat Panda type 169 front wheel drive inc. Panda Sporting inc. Panda Classic 2012- Vehicles with gas drive are not permitted to tow by manufacturer.	09/03-12		306 248 600 001			180	17.0	6.9	75	1300	306 249 300 107			S	FRE	--	E	--	--	V	90	B	
			306 249 600 001	→		180	19.0	6.9	75	1300	306 249 300 113				S	FRE	--	E	D1	--	V	90	B
		KIT		306 248 900 113			180	19.0	6.9	75	1300				S	FRE	--	E	D1	--	V	90	B
		KIT		306 249 900 113	→		180	21.0	6.9	75	1300		included in the KIT		S	FRE	--	E	D1	--	V	90	B
Fiat Panda front wheel drive exc. vehicles with gas drive (LPG/ CNG)	02/12-		306 385 600 001			60	19.0	6.1	70	1000	306 394 300 107			S	FRE	--	E	--	--	V	105	B	
			306 394 600 001			60	19.5	6.1	70	1000	306 394 300 113				S	FRE	--	E	D1	--	V	105	B
		KIT		306 385 900 113			60	21.0	6.1	70	1000				S	FRE	--	E	D1	--	V	105	B
		KIT		306 394 900 113			60	21.5	6.1	70	1000		included in the KIT		S	FRE	--	E	D1	--	V	105	B





















Fiat

Fiat Panda 4x4 Vehicles with gas drive are not permitted to tow by manufacturer.	09/04-12		306 255 600 001			90	13.1	6.9	75	1300	306 249 300 113				S	FRE	--	E	D1	--	V	90	B	
			306 254 600 001			90	15.0	6.9	75	1300														
Fiat Panda 4x4 exc. LPG/CNG inc. Panda Trekking	10/12-		306 388 600 001			60	18.0	5.8	60	900	306 394 300 107				S	FRE	--	E	--	--	V	105	B	
			306 389 600 001			60	19.5	5.8	60	900	306 394 300 113													
Fiat Panda Cross Vehicles with gas drive are not permitted to tow by manufacturer.	01/06-12		306 255 600 001			90	13.1	6.9	75	1300	306 254 300 113				S	FRE	--	E	D1	--	V	90	B	
			306 254 600 001			90	15.0	6.9	75	1300														
Fiat Panda Cross	10/14-		306 388 600 001			60	18.0	5.8	60	900	306 394 300 107				S	FRE	--	E	--	--	V	105	B	
			306 389 600 001			60	19.5	5.8	60	900	306 394 300 113													
Fiat Punto EVO	10/09-		306 375 600 001			90	19.0	6.7	75	1100	306 375 300 107				S	CAN	--	E	--	--	V	105	B	
			306 374 600 001			90	19.0	6.7	75	1100	306 375 300 113													
		KIT		306 375 900 113			90	21.0	6.7	75	1100	included in the KIT				S	CAN	--	E	D	--	V	105	B
			KIT			306 374 900 113		90	21.0	6.7	75													





























Fiat Qubo / Qubo Trekking exc. vehicles with gas drive	02/08-			306 349 600 001		150	16.5	7.5	75	1300	306 580 300 107			S	FRE	--	E	--	--	V	120	B	
				306 351 600 001		150	17.0	7.5	75	1300				306 580 300 113	S	FRE	--	E	D1	L1	V	120	B
				306 350 600 001		150	17.0	7.5	75	1300													
		KIT		306 349 900 113		150	18.5	7.5	75	1300	included in the KIT	S	FRE	--	E	D1	L1	V	120	B			
		KIT		306 350 900 113		150	19.0	7.5	75	1300													
Fiat Scudo inc. long wheelbase	09/94-01/07			315 072 600 001		60	16.4	10.9	100	2000	300 060 300 107	-07/97	--	C2	--	E1	--	--	H	45	B		
											300 060 300 113	-07/97	--	C2	--	E1	D1	L1	H	45	B		
											306 155 300 113	08/97-	S	C2	--	E1	D	--	H	45	L		
Fiat Scudo	01/07-			306 331 600 001		75	22.5	12.2	122	2200	304 400 300 107		S	CAN	C1	E	--	--	H	105	B		
				306 333 600 001		75	22.5	12.2	122	2200	304 400 300 113	S	CAN	C1	E	D	L1	H	105	B			
		KIT		306 331 900 113		75	22.5	12.2	122	2200	included in the KIT	S	CAN	C1	E	D	L1	H	105	B			
		KIT		306 333 900 113		75	24.5	12.2	122	2200													
Fiat Sedici	04/06-			306 276 600 001		120	24.0	7.1	70	1200	300 072 300 107		--	FRE	--	--	--	--	V		B		
				306 277 600 001		120	25.0	7.1	70	1200	306 520 300 113	S	FRE	--	E	D1	L1	H	45	B			
		KIT		306 276 900 113		120	26.0	7.1	70	1200	included in the KIT	S	FRE	--	E	D1	L1	H	45	B			
		KIT		306 277 900 113		120	27.0	7.1	70	1200													















Fiat

Fiat Stilo 3 doors Hatchback	10/01-			306 233 600 001	→ 	120	22.4	8.1	85	1500	300 078 300 113				--	FRE	--	--	D1	L1	V	B	
				306 231 600 001	→ 	120	18.0	8.1	85	1500													
Fiat Stilo 5 doors Hatchback	10/01-			306 233 600 001	→ 	120	22.4	8.1	85	1500	300 078 300 113				--	FRE	--	--	D1	L1	V	B	
				306 231 600 001	→ 	120	18.0	8.1	85	1500													
Fiat Stilo Multi Wagon	01/03-			306 242 600 001	→ 	120	21.5	8.1	85	1500	300 078 300 113				--	FRE	--	--	D1	L1	V	B	
				306 241 600 001	→ 	120	23.0	8.1	85	1500													
Fiat Strada inc. vehicles from 2012-	06/99-			306 319 600 001		>150	13.0	7.3	75	1300	306 204 300 113				S	FRE	--	E1	D1	L1	V	120	B
Fiat Ulysse	09/94-08/02			315 072 600 001	→ 	60	16.4	10.9	100	2000	300 060 300 107				--	C2	--	E1	--	--	H	45	B
											300 060 300 113												
Fiat Ulysse	09/02-			315 098 600 001		75	19.8	10.8	100	1900	304 400 300 107	10/05-			S	CAN	C1	E	--	--	H	105	B
				315 097 600 001		75	22.0	10.8	100	1900	304 400 300 113												
												315 097 300 107	→	-09/05	S	FRE	--	E	--	--	H	45	B
												315 097 300 113	→	-09/05	S	FRE	--	E	D1	L1	H	45	B
Fiat Ulysse	10/05-	KIT		315 098 900 113		75	21.8	10.8	100	1900	included in the KIT				S	CAN	C1	E	D	L1	H	105	B
				315 097 900 113		75	24.0	10.8	100	1900													















Ford B-Max	09/12-			307 397 600 001		60	18.5	6.8	50	900		307 397 300 107			S	A	--	E	--	--	H	60	B
				307 333 600 001		60	19.5	6.8	50	900		307 397 300 113			S	A	--	E	D1	L1	H	60	B
	KIT			307 397 900 113		60	20.5	6.8	50	900		included in the KIT			S	A	--	E	D1	L1	H	60	B
		KIT			307 333 900 113		60	21.5	6.8	50	900					S	A	--	E	D1	L1	H	60
Ford C-Max	09/10-			307 402 600 001		60	19.0	10.0	75	1800		307 442 300 107			S	CAN	C	E	--	--	H	45	B
				307 441 600 001		60	21.0	10.0	75	1800		307 442 300 113			S	CAN	C	E	D	L1	H	45	B
											307 442 300 183		06/12- For vehicles without REC and/or preparation please order additionally	S							V	30	B
	KIT			307 402 900 113		60	21.0	10.0	75	1800		included in the KIT			S	CAN	C	E	D	L1	H	45	B
KIT			307 441 900 113		60	23.0	10.0	75	1800		307 442 300 183		06/12- For vehicles without REC and/or preparation please order additionally	S							V	30	B
Ford Fiesta exc. ST / 150 HP Please check if there is a towing capacity in the car documents.	04/02-10/08			307 283 600 001		75	13.7	6.3	75	1050		300 072 300 107	-10/05	--	FRE	--	--	--	--	--	V		B
											300 072 300 113	-10/05	--	FRE	--	--	D1	L1	V			B	
											307 122 300 113	11/05-	S	FRE			D1				75	L	
Ford Fiesta exc. ST / 150 HP, Zetec S fits Zetec Please check if there is a towing capacity in the car documents.	04/02-10/08			307 286 600 001		75	17.5	6.3	75	1050		300 072 300 107	-10/05	--	FRE	--	--	--	--	V		B	
											300 072 300 113	-10/05	--	FRE	--	--	D1	L1	V			B	
											307 122 300 113	11/05-	S	FRE			D1			75	L		
Ford Fiesta exc. ST / 150 HP Please check if there is a towing capacity in the car documents.	11/05-10/08	KIT		307 283 900 113		75	15.7	6.3	75	1050		included in the KIT	11/05-	S	FRE			D1			75	L	



























Ford

Ford Fiesta exc. Titanium, Sport, Zetec S inc. Fiesta Van 2011-	10/08-			307 363 600 001		90	14.0	6.5	50	1100		307 121 300 107	-01/13	S	FRE	--	E	--	--	H	45	B	
				307 330 600 001		90	17.0	6.5	50	1100		307 121 300 113	-01/13	S	FRE	--	E	D1	L1	H	45	B	
												307 123 300 113	02/13-	S	FRE	--	--	D1	L1		60	B	
Ford Fiesta exc. Titanium, Sport, Zetec S inc. Fiesta Van 2011-	10/08-01/13	KIT		307 363 900 113		90	16.0	6.5	50	1100		included in the KIT	-01/13	S	FRE	--	E	D1	L1	H	45	B	
				307 330 900 113		90	19.0	6.5	50	1100													
Ford Fiesta exc. Titanium, Sport, Zetec S inc. Fiesta Van 2011-	02/13-	KIT		307 365 900 113		90	14.0	6.5	50	1100		included in the KIT	02/13-	S	FRE	--	--	D1	L1		60	B	
				307 341 900 113		90	19.0	6.5	50	1100													
Ford Fiesta Van exc. ST / 150 HP	07-			307 283 600 001		75	13.7	6.3	75	1050		307 122 300 113		S	FRE			D1		75	L		
				307 286 600 001	→		75	17.5	6.3	75	1050												
			KIT		307 283 900 113	→		75	15.7	6.3	75											1050	
Ford Focus C-Max Van	10/03-11/10			307 264 600 001		120	21.0	8.7	75	1590		307 264 300 107		S	FRE	--	E	--	--	H	45	B	
				343 038 600 001		90	21.5	8.7	75	1590		307 264 300 113		S	FRE	--	E	D1	--	H	45	B	
			KIT		307 438 900 113		120	23.0	8.7	75	1590		included in the KIT		S	FRE	--	E	D1	--	H	45	B
			KIT		307 407 900 113			22.5	8.7	75	1590												
Ford Focus Coupé-Convertible exc. MPS (260 HP) fits CC-3 and CC3D turbo models	04/07-			343 038 600 001		90	21.5	8.7	75	1590		300 072 300 107		--	FRE	--	--	--	--	V		B	
												300 072 300 113		--	FRE	--	--	D1	L1	V		B	





















Ford Focus Hatchback 3/5 doors inc. ST170 exc. special model Edition	10/98-10/04		307 234 600 001		90	14.4	7.3	85	1320	300 072 300 107	for vehicles without central plug connection	--	FRE	--	--	--	--	V	B	
										300 072 300 113	for vehicles without central plug connection	--	FRE	--	--	D1	L1	V	B	
										307 234 300 107	for vehicles with central plug connection	S	FRE	--	E	--	--	V	60	B
										307 234 300 113	for vehicles with central plug connection	S	FRE	--	E	D1	--	V	60	B
										307 235 300 155	additional kit for 307234300107/113 08/03-	S	--	--	E1	--	--	H	15	B
Ford Focus Hatchback exc. ST / 225 HP, exc. RS / 300 HP	10/04-01/08	KIT  KIT 	307 454 900 113		120	23.0	8.7	75	1590	included in the KIT		S	FRE	--	E	D1	--	H	60	L
			307 453 900 113			23.5	8.7	75	1590											
Ford Focus Hatchback exc. ST / 225 HP, exc. RS / 300 HP inc. vehicles 01/08-	10/04-03/11		307 264 600 001		120	21.0	8.7	75	1590	307 231 300 107	-01/08	S	FRE	--	E	--	--	V	60	L
										307 231 300 113		S	FRE	--	E	D1	--	H	60	L
										307 231 300 147	→ -01/08	S	FRE	--	E	--	--	H	60	R
										307 232 300 107	01/08-	S	FRE	--	E	--	--	H	45	B
										307 232 300 113		S	FRE	--	E	D1	L1	H	45	B
Ford Focus Hatchback exc. ST (225 HP), RS (300 HP) inc. vehicles 01/08-	10/04-03/11		343 038 600 001		90	21.5	8.7	75	1590	307 231 300 107	-01/08	S	FRE	--	E	--	--	V	60	L
										307 231 300 113		S	FRE	--	E	D1	--	H	60	L
										307 231 300 147	→ -01/08	S	FRE	--	E	--	--	H	60	R
										307 232 300 107	01/08-	S	FRE	--	E	--	--	H	45	B
										307 232 300 113		S	FRE	--	E	D1	L1	H	45	B
Ford Focus Hatchback exc. ST / 225 HP, exc. RS / 300 HP	01/08-03/11	KIT  KIT 	307 264 900 113		120	23.0	8.7	75	1590	included in the KIT		S	FRE	--	E	D1	L1	H	45	B
			307 436 900 113			23.5	8.7	75	1590											























Ford

Ford Focus Hatchback 06/12-: With vehicles with 1,0 GTDi motor it could be possible that an additional water pump is necessary. Please find details in TSB 35/2012. exc. EcoBoost S / Individual Styling Package inc. facelift 11/2014-	03/11-		307 459 600 001		60	21.0	10.0	75	1500	307 442 300 107 307 442 300 113 307 442 300 183	06/12- For vehicles without REC and/or preparation please order additionally	S	CAN	C	E	--	--	H	45	B	
			307 461 600 001		60	21.0	10.0	75	1500			S	CAN	C	E	D	L1	H	45	B	
		KIT		307 459 900 113		60	23.0	10.0	75	1500		included in the KIT	S	CAN	C	E	D	L1	H	45	B
		KIT		307 461 900 113		60	23.0	10.0	75	1500		307 442 300 183	S						V	30	B
Ford Focus Saloon	04/05-04/11		307 342 600 001		150	20.0	8.8	75	1590	307 200 300 107		S	FRE	--	E	--	--	H	45	B	
					307 343 600 001		150	20.0	8.8	75		1590	307 200 300 113		S	FRE	--	E	D1	L1	H
Ford Focus Saloon 06/12-: With vehicles with 1,0 GTDi motor it could be possible that an additional water pump is necessary. Please find details in TSB 35/2012. exc. EcoBoost S / Individual Styling Package inc. facelift 11/2014-	04/11-		307 462 600 001		90	21.0	10.0	75	1500	307 442 300 107 307 442 300 113 307 442 300 183	06/12- For vehicles without REC and/or preparation please order additionally	S	CAN	C	E	--	--	H	45	B	
					307 463 600 001	90	23.0	10.0	75	1500		S	CAN	C	E	D	L1	H	45	B	
													S						V	30	B
Ford Focus Estate For vehicles 04/02- a new inner part of the bumper must be ordered from Ford dealer, no. 1 110 935.	01/99-03/05		307 238 600 001		90	20.4	7.4	90	1300	300 072 300 113 307 234 300 107 307 234 300 113 307 235 300 155	for vehicles without central plug connection for vehicles with central plug connection for vehicles with central plug connection additional kit for 307234300107/113 08/03-	--	FRE	--	--	D1	L1	V		B	
										S		FRE	--	E	--	--	V	60	B		
												S	FRE	--	E	D1	--	V	60	B	
												S	--	--	E1	--	--	H	15	B	























Ford Focus Estate exc. ST / 225 HP inc. vehicles 01/08-	03/05-04/11			307 337 600 001			150	20.5	8.5	75	1500		307 240 300 107			S	FRE	--	E	--	--	H	45	L	
				307 338 600 001			150	26.0	8.5	75	1500		307 240 300 113			S	FRE	--	E	D1	--	H	45	L	
	KIT			307 337 900 113			150	22.5	8.5	75	1500		included in the KIT			S	FRE	--	E	D1	--	H	45	L	
		KIT			307 338 900 113			150	26.0	8.5	75	1500					S	FRE	--	E	D1	--	H	45	L
Ford Focus Estate exc. ST / 225 HP Please order separately: foam carrier for antenna for vehicles with keyless entry, order no. 907456630001. 06/12-: With vehicles with 1,0 GTDi motor it could be possible that an additional water pump is necessary. Please find details in TSB 35/2012 exc. EcoBoost S / Individual Styling Package inc. facelift 11/2014-	04/11-			307 456 600 001			90	23.0	10.0	75	1500		307 442 300 107		06/12- For vehicles without REC and/or preparation please order additionally	S	CAN	C	E	--	--	H	45	B	
				307 458 600 001			90	24.0	10.0	75	1500		307 442 300 113			S	CAN	C	E	D	L1	H	45	B	
				307 442 300 183									S									V	30	B	
		KIT			307 456 900 113			90	25.0	10.0	75	1500		included in the KIT		06/12- For vehicles without REC and/or preparation please order additionally	S	CAN	C	E	D	L1	H	45	B
	KIT				307 458 900 113			90	26.0	10.0	75	1500		307 442 300 183			S						V	30	B
Ford Fusion exc. vehicles with park distance control exc. Calero	04/02-			307 289 600 001			75	15.8	6.3	75	1050		300 072 300 107		11/05-	--	FRE	--	--	--	--	V		B	
				307 290 600 001				75	18.0	6.3	75	1050		300 072 300 113			--	FRE	--	--	D1	L1	V		B
				307 122 300 113				75						307 122 300 113			S	FRE			D1			75	L
Ford Fusion exc. vehicles with park distance control exc. Calero	11/05-	KIT		307 289 900 113			75	17.8	6.3	75	1050		included in the KIT		11/05-	S	FRE			D1			75	L	
Ford Galaxy thermal-insulation plate inc. Please order separately: bumper carrier (321330616001) exc. vehicles with park distance control!	06/95-05/00			321 329 600 001				120	17.0	12.2	85	2400		321 458 300 107		S	FRE	--	E1	--	--	H	60	B	
					321 458 300 113									321 458 300 113		S	FRE	--	E1	D1	L1	H	60	B	























Ford

Ford Galaxy thermal-insulation plate inc. inc. 4WD bumper bracket is not necessary	05/00-06		321 665 600 001			90	24.0	12.5	100	2500		321 458 300 107			S	FRE	--	E1	--	--	H	60	B
			321 775 600 001			90	26.0	12.5	100	2500		321 458 300 113			S	FRE	--	E1	D1	L1	H	60	B
	KIT		321 665 900 113			90	26.0	12.5	100	2500		included in the KIT			S	FRE	--	E1	D1	L1	H	60	B
	KIT		321 775 900 113			90	28.0	12.5	100	2500						S	FRE	--	E1	D1	L1	H	60
Ford Galaxy 7 seater without height control	05/06-		307 306 600 001			90	17.0	11.1	90	2000		307 400 300 107			S	CAN	C	E	--	--	H	45	B
			307 355 600 001			90	19.5	11.1	90	2000		307 400 300 113			S	CAN	C	E	D	L1	H	45	B
	KIT		307 306 900 113			90	19.0	11.1	90	2000		included in the KIT			S	CAN	C	E	D	L1	H	45	B
	KIT		307 355 900 113			90	21.5	11.1	90	2000						S	CAN	C	E	D	L1	H	45
Ford Galaxy 7 seater with height control	05/06-		307 356 600 001			90	19.5	11.1	90	2000		307 400 300 107			S	CAN	C	E	--	--	H	45	B
												307 400 300 113			S	CAN	C	E	D	L1	H	45	B
Ford Grand C-Max	09/10-		307 402 600 001			60	19.0	10.0	75	1800		307 442 300 107			S	CAN	C	E	--	--	H	45	B
			307 441 600 001			60	21.0	10.0	75	1800		307 442 300 113			S	CAN	C	E	D	L1	H	45	B
											307 442 300 183		06/12- For vehicles without REC and/or preparation please order additionally	S							V	30	B
	KIT		307 402 900 113			60	21.0	10.0	75	1800		included in the KIT			S	CAN	C	E	D	L1	H	45	B
KIT		307 441 900 113			60	23.0	10.0	75	1800		307 442 300 183		06/12- For vehicles without REC and/or preparation please order additionally	S							V	30	B



















Ford Kuga	05/08-04/13			307 345 600 001		90	26.0	10.6	105	2100		307 280 300 107			S	FRE	--	E	--	--	H	90	B
				307 464 600 001		90	25.0	10.6	105	2100		307 280 300 113			S	FRE	--	E	D1	L1	H	90	B
		KIT		307 345 900 113		90	28.0	10.6	105	2100		included in the KIT			S	FRE	--	E	D1	L1	H	90	B
		KIT		307 464 900 113		90	27.0	10.6	105	2100						S	FRE	--	E	D1	L1	H	90
Ford Kuga	04/13-			307 473 600 001		120	23.0	11.0	100	2100		307 474 300 107		for vehicles with preparation	S	CAN	C	E	--	--	H	60	B
				307 474 600 001		120	25.0	11.0	100	2100		307 474 300 113		for vehicles with preparation	S	CAN	C	E	D	L1	H	60	B
												307 474 300 183		For vehicles without preparation please order additionally	S						V	45	B
		KIT		307 473 900 113		120	25.0	11.0	100	2100		included in the KIT		for vehicles with preparation	S	CAN	C	E	D	L1	H	60	B
KIT		307 474 900 113			27.0	11.0	100	2100		307 474 300 183		For vehicles without preparation please order additionally	S						V	45	B		
Ford Maverick year of construction: 2005	03/04-			307 339 600 001	 	150	20.0	10.0	80	2000		300 072 300 113			--	FRE	--	--	D1	L1	V		B
				307 340 600 001	 	150	21.0	10.0	80	2000													
Ford Mondeo 4/5 doors	01/15-			307 475 600 001								307 478 300 107			S	FRE	C	E	--	--	H	90	B
				307 476 600 001								307 478 300 113			S	FRE	C	E	D1	L1	H	90	B
		KIT		307 475 900 113								included in the KIT			S	FRE	C	E	D1	L1	H	90	B
		KIT		307 476 900 113												S	FRE	C	E	D1	L1	H	90

















Ford

Ford Mondeo 4 doors models 10/10- = visible cutout exc. Titanium X Sport	06/07-14		307 331 600 001		90	17.5	11.6	90	2120	307 400 300 107	S	CAN	C	E	--	--	H	45	B	
			307 332 600 001		90	17.5	11.6	90	2120	307 400 300 113	S	CAN	C	E	D	L1	H	45	B	
Ford Mondeo 5 doors	06/07-12/14		307 328 600 001		90	17.0	11.6	90	2120	307 400 300 107	S	CAN	C	E	--	--	H	45	B	
			307 329 600 001		90	17.0	11.6	90	2120	307 400 300 113	S	CAN	C	E	D	L1	H	45	B	
		KIT KIT	307 328 900 113		19.0	9.0	90	2120	included in the KIT	S	CAN	C	E	D	L1	H	45	B		
			307 329 900 113		90	19.0	11.6	90		2120										
Ford Mondeo Saloon/ Hatchback hatchback, inc. 4x4, exc. RS	03/93-09/96		307 186 600 001	→ 	120	15.0	9.0	75	1600	300 060 300 107	--	C2	--	E1	--	--	H	45	B	
			300 060 300 113	--	C2	--	E1	D1	L1	H	45	B								
Ford Mondeo Saloon/ Hatchback liftback and notchback	10/96-10/00		307 219 600 001	→ 	120	17.2	9.0	75	1600	300 060 300 107	--	C2	--	E1	--	--	H	45	B	
			300 060 300 113	--	C2	--	E1	D1	L1	H	45	B								
Ford Mondeo Saloon/ Hatchback exc. ST 220 With models Ghia/Titanium/ Platinum 01/05- we recommend to exchange the spoiler for optical reasons into the standard spoiler.	11/00-06/07		307 241 600 001		60	18.3	11.0	120	2000	307 242 300 107	S	FRE	--	E	--	--	V	75	B	
			307 242 600 001	→ 	60	19.5	11.0	120	2000	307 242 300 113	S	FRE	--	E	D1	--	V	75	B	
Ford Mondeo Estate inc. 4 WD, exc. RS, inc. models from '96	05/93-10/00		307 194 600 001	→ 	90	18.0	9.0	75	1600	307 194 300 107	→ 	S	C2	--	E1	--	--	H	60	B
Ford Mondeo Estate exc. vehicles with height control exc. ST220	11/00-06/07		307 245 600 001	→ 	60	22.0	11.0	120	2000	307 244 300 107	S	FRE	--	E	--	--	V	75	L	
			307 247 600 001	→ 	60	22.1	11.0	120	2000	307 244 300 113	S	FRE	--	E	D1	--	V	75	L	
Ford Mondeo Estate inc. vehicles with height control exc. ST220	11/00-06/07		307 431 600 001		120	19.0	11.0	85	2000	307 244 300 107	S	FRE	--	E	--	--	V	75	L	
			307 244 300 113	S	FRE	--	E	D1	--	V	75	L								









Ford Mondeo Estate Ghia / Titanium / Platinum exc. ST220	05/05-06/07		307 429 600 001		120	19.0	11.0	80	2000	307 244 300 107	S	FRE	--	E	--	--	V	75	L	
				307 430 600 001		120	19.0	11.0	80	2000	307 244 300 113	S	FRE	--	E	D1	--	V	75	L
Ford Mondeo Estate for vehicles with height control	06/07-12/14		307 336 600 001		150	19.2	11.6	90	2120	307 400 300 107	S	CAN	C	E	--	--	H	45	B	
											307 400 300 113	S	CAN	C	E	D	L1	H	45	B
Ford Mondeo Estate exc. vehicles with height control	06/07-12/14		307 403 600 001		150	17.5	11.6	90	2120	307 400 300 107	S	CAN	C	E	--	--	H	45	B	
				307 455 600 001		150	19.5	11.6	90	2120	307 400 300 113	S	CAN	C	E	D	L1	H	45	B
		KIT		307 403 900 113		90	19.5	11.6	90	2120	included in the KIT	S	CAN	C	E	D	L1	H	45	B
		KIT		307 455 900 113		90	21.5	11.6	90	2120										
Ford Mondeo Estate	01/15-		307 475 600 001							307 478 300 107	S	FRE	C	E	--	--	H	90	B	
				307 476 600 001							307 478 300 113	S	FRE	C	E	D1	L1	H	90	B
		KIT		307 475 900 113							included in the KIT	S	FRE	C	E	D1	L1	H	90	B
		KIT		307 476 900 113																
Ford Ranger I	-12/06		307 372 600 001		60	32.0	14.1	100	2800	300 052 300 107	--	FRE	--	E1	--	--	V		B	
											300 052 300 113	--	FRE	--	E1	D1	--	V		B
Ford Ranger II 4 WD	12/06-03/12		307 376 600 001		60	32.0	14.9	150	3000	307 376 300 113		S	C2	--	E1	D	--	V		B

Ford

Ford Ranger III for vehicles with bumper with integrated step	03/12-		307 443 600 001			90	41.0	17.2	200	3500		343 069 300 113			S	CAN	C	E	D	--	V	60		
		KIT		307 443 900 113			90	43.0	17.2	200	3500		included in the KIT			S	CAN	C	E	D	--	V	60	
Ford S-Max without height control with styling package by Ford Individual + for S-Max Titanium S = visible cutout	05/06-		307 304 600 001			90	17.7	11.1	90	2000		307 400 300 107			S	CAN	C	E	--	--	H	45	B	
			307 305 600 001			90	19.5	11.1	90	2000		307 400 300 113			S	CAN	C	E	D	L1	H	45	B	
		KIT		307 304 900 113			90	19.7	11.1	90	2000		included in the KIT			S	CAN	C	E	D	L1	H	45	B
		KIT		307 305 900 113			90	21.5	11.1	90	2000					S	CAN	C	E	D	L1	H	45	B
Ford S-Max with height control with styling package by Ford Individual + for S-Max Titanium S = visible cutout	05/06-		307 308 600 001			90	19.5	11.1	90	2000		307 400 300 107			S	CAN	C	E	--	--	H	45	B	
												307 400 300 113			S	CAN	C	E	D	L1	H	45	B	
Ford Transit Connect Tourneo	03-13		307 262 600 001			120	16.0	8.1	75	1250		307 360 300 107			S	FRE	--	E1	--	--	H	60	B	
												307 360 300 113			S	FRE	--	E1	D1	L1	H	60	B	
		KIT		307 262 900 113		120	18.0	8.1	75	1250		included in the KIT			S	FRE	--	E1	D1	L1	H	60	B	
Ford Tourneo Custom Van	11/12-		307 382 600 001			30	17.2	14.9	120	2800		307 385 300 107	→		S	CAN	C	E	--	--	V	90	B	
			307 385 600 001			30	23.0	14.9	120	2800		307 385 300 113	→		S	CAN	C	E	D	L1	V	90	B	
												307 386 300 107			S	CAN		E2	--	--	V	90	B	
												307 386 300 113			S	CAN		E2	D	L1	V	90	B	
		KIT		307 382 900 113			30	19.0	14.9	120	2800		included in the KIT	→		S	CAN	C	E	D	L1	V	90	B
KIT		307 385 900 113			30	25.0	14.9	120	2800						S	CAN	C	E	D	L1	V	90	B	























Ford Tourneo/Transit Connect	02/14-			307 500 600 001			90	15.5	8.3	75	1250		307 500 300 107			S	CAN	E	--	--	H	60	B		
				307 526 600 001			90	17.2	8.3	75	1250		307 500 300 113			S	CAN	E	D	L1	H	60	B		
				307 501 600 001			90	15.5	8.3	75	1250														
		KIT		307 500 900 113			90	17.5	8.3	75	1250		included in the KIT			S	CAN	E	D	L1	H	60	B		
		KIT		307 501 900 113			90	17.5	8.3	75	1250														
Ford Tourneo/Transit Courier	06/14-			307 521 600 001		60	17.0	8.3	75	1200		307 522 300 113			S	A	C1	E1	D1	--	H	75	B		
				307 553 600 001		60	19.0	8.3	75	1200															
				307 522 600 001		60	19.0	8.3	75	1200															
		KIT		307 521 900 113		60	19.0	8.3	75	1200		included in the KIT			S	A	C1	E1	D1	--	H	75	B		
		KIT		307 522 900 113		60	21.0	8.3	75	1200															
Ford Transit Connect inc. RS with double tube exhaust system	03-13			307 262 600 001		120	16.0	8.1	75	1250		307 360 300 107			S	FRE	--	E1	--	--	H	60	B		
												307 360 300 113			S	FRE	--	E1	D1	L1	H	60	B		
		KIT		307 262 900 113		120	18.0	8.1	75	1250		included in the KIT			S	FRE	--	E1	D1	L1	H	60	B		

























Ford

Ford Transit Custom Van	11/12-		307 382 600 001			30	17.2	14.9	120	2800		307 385 300 107	→		S	CAN	C	E	--	--	V	90	B	
			307 385 600 001			30	23.0	14.9	120	2800		307 385 300 113	→		S	CAN	C	E	D	L1	V	90	B	
												307 386 300 107			S	CAN		E2	--	--	V	90	B	
											307 386 300 113			S	CAN		E2	D	L1	V	90	B		
	KIT		307 382 900 113			30	19.0	14.9	120	2800		included in the KIT	→		S	CAN	C	E	D	L1	V	90	B	
	KIT		307 385 900 113			30	25.0	14.9	120	2800					S	CAN		E2	D	L1	V	90	B	
Ford Transit Van name of the type begins with "F", towing bracket inc. towball (329076600001) exc. vehicles with step suitable step: 307267600001 For vehicles from 08/2004 please order separately at Ford dealers: reinforcement for longitudinal beam 1 x FINIS 4583024, nut 2 x FINIS 4105891, screw 2 x FINIS 4046120	04/00-		307 260 600 001			60	19.8	15.3	112	2800		307 260 300 107			--	FRE	--	E1	--	--	V	75	B	
			307 260 300 113												--	FRE	--	--	D1	--	V	75	B	
			KIT		307 260 900 113			60	21.8	15.3	112	2800		included in the KIT			--	FRE	--	--	D1	--	V	75
Ford Transit Van 4,6 t max. total weight Only available at Ford dealers.	10/07-																							
Ford Transit Van V363	05/14-		307 465 600 001			60		17.4	150	3500		307 386 300 107			S	CAN		E2	--	--	V	90	B	
													307 386 300 113			S	CAN		E2	D	L1	V	90	B
Ford Transit Chassis Cab V184/185 name of the type begins with "F" towing bracket inc. towball 329076600001 towball for swap system: 329059600001 mounting kit for automatic bolt coupling: 907202650002	04/00-07/06		307 258 600 001	→		30	17.4	15.3	112	2800		300 201 300 113		-05/14	--	A	--	E1	D1	--	V		B	
Ford Transit Chassis Cab V347/V348/V363 name of the type begins with "F" towing bracket inc. towball 329076600001 towball for swap system: 329059600001 mounting kit for automatic bolt coupling: 907202650002	07/06-		307 378 600 001			60	22.0	15.3	112	2800		300 201 300 113		-05/14	--	A	--	E1	D1	--	V		B	
													307 386 300 107		06/14-	S	CAN		E2	--	--	V	90	B
														307 386 300 113		06/14-	S	CAN		E2	D	L1	V	90

Ford Transit Chassis Cab 4,6 t max. total weight Only available at Ford dealers.	10/07-																			
---	--------	--	--	--	--	--	--	--	--	--	--	--	--	--	--	--	--	--	--	--



















Honda

























Honda Accord Saloon exc. Estate	02/03-08		338 074 600 001		90	21.0	8.3	75	1500	300 072 300 107	--	FRE	--	--	--	V	B		
										300 072 300 113	--	FRE	--	--	D1	L1	V	B	
Honda Accord Saloon (CU) exc. type S	08-	 	338 065 600 001		90	20.0	9.5	75	1700	300 072 300 107	--	FRE	--	--	--	V	B		
			338 066 600 001		90	21.0	9.5	75	1700	300 072 300 113	--	FRE	--	--	D1	L1	V	B	
Honda Accord Tourer (CL)	04/03-08	 	338 086 600 001		120	21.0	8.8	75	1500	300 072 300 107	--	FRE	--	--	--	V	B		
			338 087 600 001		120	21.0	8.8	75	1500	300 072 300 113	--	FRE	--	--	D1	L1	V	B	
Honda Accord Tourer (CW)	08-	 	338 065 600 001		90	20.0	9.5	75	1700	300 072 300 107	--	FRE	--	--	--	V	B		
			338 066 600 001		90	21.0	9.5	75	1700	300 072 300 113	--	FRE	--	--	D1	L1	V	B	
Honda CRV	01/07-11/12	KIT 	338 053 600 001		60	20.0	10.4	100	2000	338 680 300 113	S	FRE	--	E2	D1	--	H	60	B
			338 053 900 113		60	22.0	10.4	100	2000	included in the KIT	S	FRE	--	E2	D1	--	H	60	B
Honda CRV inc. vehicles with sport equipment	01/07-11/12	KIT 	338 094 600 001		90	27.0	10.5	80	2000	338 680 300 113	S	FRE	--	E2	D1	--	H	60	B
			338 094 900 113		90	29.0	10.5	80	2000	included in the KIT	S	FRE	--	E2	D1	--	H	60	B
Honda CRV	11/12-	 	338 107 600 001		90	19.0	10.7	100	2000	300 210 300 107	--	A	--	--	--	V	B		
			338 108 600 001		90	20.0	10.7	100	2000	300 210 300 113	--	A	--	E1	D1	L1	V	90	B

Honda Civic 3 / 5 doors exc. Civic "R"	01/06-		338 091 600 001		60	22.0	8.3	75	1500		300 072 300 107			--	FRE	--	--	--	--	V		B
				338 092 600 001		60	23.0	8.3	75	1500		300 072 300 113			--	FRE	--	--	D1	L1	V	
Honda Civic 5 doors	01/12-		338 103 600 001				8.3	75	1500		300 210 300 107			--	A	--	--	--	--	V		B
				338 104 600 001				8.3	75	1500		300 210 300 113			--	A	--	E1	D1	L1	V	90
Honda Civic Tourer	02/14-		338 119 600 001		90	24.0	8.2	75	1400		300 210 300 107			--	A	--	--	--	--	V		B
				338 120 600 001		75	26.0	8.2	75	1400		300 210 300 113			--	A	--	E1	D1	L1	V	90
Honda FRV	05-		338 073 600 001		100	24.0	8.7	90	1500					--	FRE	--	--	D1	L1	V	90	B
				338 075 600 001		100	24.0	8.7	90	1500		300 073 300 113			--	FRE	--	--	D1	L1	V	90
Honda Jazz	-11/08		338 060 600 001		60	17.5	5.9	70	1000		300 072 300 107			--	FRE	--	--	--	--	V		B
				338 059 600 001		60	18.5	5.9	70	1000		300 072 300 113			--	FRE	--	--	D1	L1	V	
Honda Jazz	11/08-		338 115 600 001		90	19.0	6.6	80	1100		300 210 300 107			--	A	--	--	--	--	V		B
				338 116 600 001		90	21.0	6.6	80	1100		300 210 300 113			--	A	--	E1	D1	L1	V	90























Hummer







Hummer II	02-		342 160 600 001	→		150	29.0	18.3	140	3500		300 210 300 113				--	A	--	E1	D1	L1	V	90	B
-----------	-----	---	-----------------	---	---	-----	------	------	-----	------	--	-----------------	--	--	--	----	---	----	----	----	----	---	----	---

Hyundai Accent Hatch- and Notchback	06/06-		346 068 600 001			90	20.0	6.6	50	1100		300 072 300 107			--	FRE	--	--	--	--	V		B
																			--	FRE	--	--	D1
Hyundai Grand Santa Fe	02/14-		346 086 600 001			60	23.0	11.4	100	2000		346 076 300 107			S	A	--	--	--	--		90	B
			346 087 600 001				60	25.0	11.4	100	2000		346 076 300 113			S	A	--	--	D	L1		90
		KIT	346 086 900 113			60	24.0	11.4	100	2000		included in the KIT			S	A	--	--	D	L1		90	B
		KIT	346 087 900 113			60	26.0	11.4	100	2000						S	A	--	--	D	L1		90
Hyundai H1 / H300 / iLoad Van	08-		346 056 600 001			60	28.0	13.5	100	2400		346 057 300 113			S	C2	--	E1	D1	L1	V	60	L
			346 057 600 001				60	28.0	13.5	100	2400						S	C2	--	E1	D1	L1	V
Hyundai i 10	01/08-10/13		346 047 600 001			90	19.0	5.2	32	800		300 210 300 107			--	A	--	--	--	--	V		B
																	--	A	--	E1	D1	L1	V
Hyundai i 10 is not permitted to tow by manufacturer.	11/13-																						
Hyundai i 20 3/5 doors	01/09-12/14		346 084 600 001			90	20.0	6.6	50	1200		300 210 300 107			--	A	--	--	--	--	V		B
																	--	A	--	E1	D1	L1	V
Hyundai i 20 3/5 doors	01/15-		346 092 600 001			60	19.0	6.8	50	1110		300 210 300 107			--	A	--	--	--	--	V		B
			346 093 600 001				60	22.0	6.8	50	1110		300 210 300 113			--	A	--	E1	D1	L1	V	90
Hyundai i 30 Hatchback	09/07-02/12		345 028 600 001			90	17.5	8.6	75	1500		300 210 300 107			--	A	--	--	--	--	V		B
																	--	A	--	E1	D1	L1	V



Hyundai I 40 cw Estate	07/11-			346 082 600 001			90	18.0	9.9	80	1800		346 066 300 113				S	FRE	--	E1	D1	L1	H	60	B		
				346 083 600 001		90	21.0	9.9	80	1800																	
		KIT			346 082 900 113			90	20.0	9.9	80	1800	included in the KIT						S	FRE	--	E1	D1	L1	H	60	B
					346 083 900 113		90	23.0	9.9	80	1800																
Hyundai IX 20	11/10-			346 063 600 001			90	20.0	7.6	75	1300		346 064 300 107				S	A	--	E1	--	--	V	75	B		
				346 064 600 001		90	21.0	7.6	75	1300	346 064 300 113									S	A	--	E1	D1	--	V	75
		KIT			346 063 900 113			90	22.0	7.6		75	1300	included in the KIT									S	A	--	E1	D1
					346 064 900 113		90	23.0	7.6	75	1300																
Hyundai IX 35	03/10-			346 048 600 001			90	23.0	11.1	96	2400		346 049 300 107					S	A	--	E2	--	--	V	90	B	
				346 049 600 001		90	25.0	11.1	96	2400	346 049 300 113										S	A	--	E2	D1	L1	V
		KIT			346 048 900 113			90	25.0	11.1		96	2400	included in the KIT									S	A	--	E2	D1
					346 049 900 113		90	27.0	11.1	96	2400																
Hyundai Matrix inc. facelift 08-	01-			346 050 600 001			90	19.0	8.1	60	1400		300 072 300 107				--	FRE	--	--	--	--	V		B		
																	300 072 300 113	--	FRE	--	--	D1	L1	V		B	
Hyundai Santa Fe type SM exc. vehicles with 3. seat row	00-03/06			346 011 600 001			90	26.0	12.0	100	2300		300 061 300 107				--	C2	--	E1	--	--	V		B		
																	300 061 300 113	--	C2	--	--	--	V		B		

Hyundai



















Hyundai Santa Fe type CM	03/06-09/12			346 020 600 001		90	26.0	13.6	100	3000		346 810 300 107	→	09/09-	S	FRE	--	E1	--	--	H	75	B	
				346 021 600 001		90	29.0	13.6	100	3000		346 811 300 113			S	FRE	--	--	D1	L1	H		B	
		KIT		346 810 900 113		90	28.0	13.6	100	3000		included in the KIT	→		discontinued model:	S	FRE	--	E1	D1	L1	H	75	B
		KIT		346 811 900 113		90	29.0	13.6	100	3000							S	FRE	--	E1	D1	L1	H	75
Hyundai Santa Fe exc. Grand Santa Fe	09/12-			346 075 600 001		90	23.0	12.5	100	2500		346 076 300 107			S	A	--	--	--	--		90	B	
				346 076 600 001		90	25.0	12.5	100	2500		346 076 300 113			S	A	--	--	D	L1		90	B	
		KIT		346 075 900 113		90	25.0	12.5	100	2500		included in the KIT			S	A	--	--	D	L1		90	B	
		KIT		346 076 900 113		90	27.0	12.5	100	2500					S	A	--	--	D	L1		90	B	
Hyundai Sonata exc. vehicles with 2 l motor	05-			346 058 600 001	→ 	90	20.0	9.7	75	1800		300 210 300 107			--	A	--	--	--	--	V		B	
				346 059 600 001		90	20.0	9.7	75	1800		300 210 300 113			--	A	--	E1	D1	L1	V	90	B	
Hyundai Terracan towball for swap system: 329059600001	10/01-			346 015 600 001		60	25.8	15.3	140	3500		300 072 300 107			--	FRE	--	--	--	--	V		B	
												300 072 300 113			--	FRE	--	--	D1	L1	V		B	
Hyundai Trajet	01-			346 014 600 001	→ 	60	20.6	10.8	80	1950		300 061 300 107			--	C2	--	E1	--	--	V		B	
												300 061 300 113			--	C2	--	--	--	--	V		B	

























Hyundai Tucson	09/04-			346 018 600 001		90	20.6	10.9	90	2200		346 018 300 113			S	FRE	--	E1	D1	L1	H	45	B
				346 019 600 001		90	23.5	10.9	90	2200													
		KIT		346 018 900 113		90	22.6	10.9	90	2200		included in the KIT			S	FRE	--	E1	D1	L1	H	45	B
		KIT		346 019 900 113		90	25.5	10.9	90	2200													

Isuzu









Isuzu D-Max	01/07-			342 170 600 001 →			100	33.0	15.0	120	3000		300 052 300 107			--	FRE	--	E1	--	--	V	B
Isuzu D-Max 4x4 exc. 4x2 exc. vehicles with double tube exhaust system	06/12-			342 195 600 001			90	29.0	15.0	120	3000												



























Jeep

Jeep Cherokee KJ	09/01-03/08		342 094 600 001 →	90	24.0	14.5	140	3500	300 065 300 005	for vehicles with earth switched rear fog lights please order separately	--	--	--	E1	--	--	H	15	B		
			342 093 600 001 →	90	25.0	14.5	140	3500			300 210 300 107	--	A	--	--	--	--	V		B	
											300 210 300 113	--	A	--	E1	D1	L1	V	90	B	
Jeep Cherokee	09/01-03/08		342 118 600 001	180	35.0	14.4	80	2720	300 065 300 005	for vehicles with earth switched rear fog lights please order separately	--	--	--	E1	--	--	H	15	B		
											300 210 300 107	--	A	--	--	--	--	V		B	
											300 210 300 113	--	A	--	E1	D1	L1	V	90	B	
Jeep Cherokee	03/08-03/14		342 142 600 001	45	35.0	15.3	140	3500	300 210 300 107		--	A	--	--	--	--	V		B		
				342 131 600 001	90	30.0	15.3	140			3500	300 210 300 113	--	A	--	E1	D1	L1	V	90	B
Jeep Cherokee Onroad / KL	04/14-		342 208 600 001		60	32.0	12.4	150	2500	342 200 300 113		S	A	E1	D	L1	V	150	B		
				342 207 600 001		60	33.0	12.4	150											2500	
Jeep Cherokee Offroad / Trailhawk / KL	04/14-		342 209 600 001		60	32.0	12.4	150	2500	342 200 300 113		S	A	E1	D	L1	V	150	B		
Jeep Commander	05/06-		342 102 600 001		30	9.0	15.6	150	3500	342 103 300 113		S	A	--	--	D	L1	H	90	B	
				342 103 600 001		30	11.5	15.6	150												3500
		KIT		342 102 900 113		30	11.0	15.6	150	3500	included in the KIT		S	A	--	--	D	L1	H	90	B
			KIT		342 103 900 113		30	13.5	15.6	150											





























Jeep Compass	11/06-			342 112 600 001		90	18.0	9.9	105	2000		300 210 300 107			--	A	--	--	--	--	V		B
				342 113 600 001		90	19.5	9.9	105	2000		300 210 300 113			--	A	--	E1	D1	L1	V	90	
Jeep Grand Cherokee	04/99-06/05			342 085 600 001		90	23.9	14.3	140	3500		300 210 300 107			--	A	--	--	--	--	V		B
												300 210 300 113			--	A	--	E1	D1	L1	V	90	
Jeep Grand Cherokee exc. SRT8, 6.1 HEMI	06/05-03/11			342 102 600 001		30	9.0	15.6	150	3500		342 097 300 113	-03/06		S	A	--	--	D	L1	H	75	B
				342 103 600 001		30	11.5	15.6	150	3500		342 103 300 113			S	A	--	--	D	L1	H	90	
Jeep Grand Cherokee exc. SRT8, 6.1 HEMI	03/06-03/11	KIT		342 102 900 113		30	11.0	15.6	150	3500		included in the KIT			S	A	--	--	D	L1	H	90	B
				342 103 900 113		30	13.5	15.6	150	3500													
Jeep Grand Cherokee exc. SRT8/Summit inc. Facelift 06/13-	04/11-			342 184 600 001		90	21.0	15.6	140	3500		342 184 300 113	-06/13		S	A	C	--	D	L1	V	120	B
												342 185 300 157											
												342 190 300 113	06/13-	S	A	--	E1	D	L1	V	120	B	
Jeep Grand Cherokee exc. SRT8 inc. Summit	04/11-			342 221 600 001		90	23.0	16.0	140	3500		342 184 300 113	-06/13		S	A	C	--	D	L1	V	120	B
												342 190 300 113	06/13-		S	A	--	E1	D	L1	V	120	
Jeep Grand Cherokee exc. SRT8	04/11-06/13			342 185 600 001		90	21.0	15.6	140	3500		342 184 300 113	-06/13		S	A	C	--	D	L1	V	120	B
												342 185 300 157											
Jeep Grand Cherokee exc. SRT8 inc. Summit	04/11-06/13	KIT		342 185 900 113		90	23.0	15.6	140	3500		included in the KIT	-06/13		S	A	C	--	D	L1	V	120	B
Jeep Grand Cherokee exc. SRT8 inc. Summit	06/13-	KIT		342 190 900 113		90	23.0	16.0	140	3500		included in the KIT	06/13-		S	A	--	E1	D	L1	V	120	B























Jeep

Jeep Patriot	08/07-		342 112 600 001		90	18.0	9.9	105	2000	300 210 300 107	--	A	--	--	--	--	V	B	
			342 113 600 001		90	19.5	9.9	105	2000	300 210 300 113	--	A	--	E1	D1	L1	V	90	B
Jeep Renegade	08/14-		342 196 600 001		90	20.0	8.7	100	1500	342 197 300 107	S	FRE	--	E	--	--	V	120	B
			342 197 600 001		90	21.0	8.7	100	1500	342 197 300 113	S	FRE	--	E	D	L1	V	120	B
		KIT	342 196 900 113		90	22.0	8.7	100	1500	included in the KIT	S	FRE	--	E	D	L1	V	120	B
			KIT	342 197 900 113		90	23.0	8.7	100		1500	S	FRE	--	E	D	L1	V	120
Jeep Wrangler	10/96-04/07		342 120 600 001		60	28.0	10.0	80	1975	300 210 300 107	--	A	--	--	--	--	V	B	
										300 210 300 113	--	A	--	E1	D1	L1	V	90	B
Jeep Wrangler	04/07-		342 104 600 001		60	12.0	15.0	170	3500	300 210 300 107	--	A	--	--	--	--	V	B	
			342 105 600 001		60	12.0	15.0	170	3500	300 210 300 113	--	A	--	E1	D1	L1	V	90	B











Kia Carens	10/06-03/12		345 075 600 001		90	24.0	9.1	75	1500	300 061 300 107			--	C2	--	E1	--	--	V		B		
																	--	C2	--	--	--	V	
Kia Carens	03/12-	 	345 091 600 001		90	20.0	9.1	75	1500	300 210 300 107			--	A	--	--	--	--	V		B		
			345 092 600 001			90	22.0	9.1	75	1500			300 210 300 113	--	A	--	E1	D1	L1	V	90	B	
Kia Sedona	99-07/06		345 015 600 001	→ 	90	19.0	11.5	80	2000	300 210 300 113			--	A	--	E1	D1	L1	V	90	B		
Kia Sedona	05/06-	 	345 054 600 001		90	30.0	11.9	80	2000	300 210 300 113			--	A	--	E1	D1	L1	V	90	B		
			345 055 600 001		→ 	120	29.0	11.9	80	2000			345 760 300 113	→	S	FRE	--	E	D1	--	H	60	L
Kia Cee'd 4/5 doors	01/07-		345 028 600 001		90	17.5	8.6	75	1500	345 028 300 113		09/09-	S	A	--	E	D1	--	V	75	B		
													-09/09	S	FRE	--	E1	D	L1	V	90	L	
Kia Cee'd 4/5 doors	01/07-06/12		345 027 600 001		90	16.0	8.6	75	1500	300 210 300 113		-09/09	--	A	--	E1	D1	L1	V	90	B		
													09/09-	S	A	--	E	D1	--	V	75	B	
Kia Cee'd 5 doors	06/12-		345 086 600 001		60	20.0	8.3	75	1500	345 086 300 107			S	A	--	E2	--	--	V	90	B		
															S	A	--	E2	D1	--	V	90	B
Kia Cee'd Sporty Wagon	07/07-09/12	 	345 027 600 001		90	16.0	8.6	75	1500	300 073 300 113		-09/09	--	FRE	--	--	D1	L1	V	90	B		
			345 059 600 001			90	17.5	8.6	75	1500		345 059 300 107	→	09/09-	S	A	--	--	--	--	V	75	L
														09/09-	S	A	--	--	D1	L1	V	75	L
Kia Cee'd Sporty Wagon	09/09-	KIT  KIT 	345 027 900 113		90	18.0	8.6	75	1500	included in the KIT		09/09-	S	A	--	--	D1	L1	V	75	L		
			345 059 900 113			90	19.5	8.6	75													1500	

























Kia

Kia Cee'd sw/Sportswagon	10/12-			345 088 600 001		90	20.0	8.5	75	1500		345 086 300 107			S	A	--	E2	--	--	V	90	B	
				345 089 600 001		90	23.0	8.5	75	1500		345 086 300 113			S	A	--	E2	D1	--	--	V	90	B
		KIT		345 088 900 113		90	22.0	8.5	75	1500		included in the KIT			S	A	--	E2	D1	--	--	V	90	B
				345 089 900 113		90	25.0	8.5	75	1500						S	A	--	E2	D1	--	--	V	90
Kia Cerato Hatch- and Notchback	04-			345 057 600 001		90	18.0	8.0	58	1450		300 072 300 107			--	FRE	--	--	--	--	V		B	
				345 057 600 001		90	18.0	8.0	58	1450		300 072 300 113			--	FRE	--	--	D1	L1	--	V		B
Kia Magentis	02/06-07/09			345 056 600 001		60	19.0	9.4	75	1700		300 072 300 107			--	FRE	--	--	--	--	V		B	
				345 056 600 001		60	19.0	9.4	75	1700		300 072 300 113			--	FRE	--	--	D1	L1	--	V		B
Kia Optima	04/12-			345 081 600 001		60	17.5	8.0	60	1300		345 082 300 113			S	A	--	--	--	D1	--	V	90	B
				345 082 600 001		60	19.0	8.0	60	1300						S	A	--	--	--	D1	--	V	90
		KIT		345 081 900 113		60	19.5	8.0	60	1300		included in the KIT			S	A	--	--	--	D1	--	V	90	B
				345 082 900 113		60	21.0	8.0	60	1300						S	A	--	--	--	D1	--	V	90
Kia Picanto inc. facelift 08-	04-05/11			345 058 600 001		90	18.0	5.9	40	1000		300 072 300 107			--	FRE	--	--	--	--	V		B	
				345 058 600 001		90	18.0	5.9	40	1000		300 072 300 113			--	FRE	--	--	D1	L1	--	V		B









Kia Picanto	05/11-			345 078 600 001		90	16.0	5.5	28	700	345 080 300 113				S	A	--	E1	D1	L1	V	75	B	
				345 080 600 001		90	17.0	5.5	28	700														
		KIT			345 077 900 113		90	18.0	5.5	28	700	included in the KIT				S	A	--	E1	D1	L1	V	75	B
					345 080 900 113		90	19.0	5.5	28	700													
Kia ProCee'd	08-13			345 028 600 001		90	17.5	8.6	75	1500	300 210 300 113	-09/09	--	A	--	E1	D1	L1	V	90	B			
												345 028 300 107	09/09-	S	A	--	E	--	--	V	75	B		
													345 028 300 113	09/09-	S	A	--	E	D1	--	V	75	B	
Kia ProCee'd exc. Pro Cee'd GT	03/13-			345 086 600 001		60	20.0	8.3	75	1500	345 086 300 107			S	A	--	E2	--	--	V	90	B		
												345 086 300 113			S	A	--	E2	D1	--	V	90	B	
Kia Rio Hatchback	08/05-09/09			345 026 600 001	→	90	16.5	7.6	50	1100	300 061 300 107			--	C2	--	E1	--	--	V		B		
												300 061 300 113			--	C2	--	--	--	V		B		
Kia Rio Hatchback	09/09-08/11			345 076 600 001		90	22.0	6.6	50	1100	300 072 300 107			--	FRE	--	--	--	V		B			
						345 077 600 001		90	25.0	6.6	50	1100	300 072 300 113			--	FRE	--	--	D1	L1	V		B
Kia Rio Hatchback	08/11-			345 090 600 001		45	19.0	6.8	50	1100	345 084 300 113			S	A	--	E1	D1	--	V	75	B		
			KIT		345 090 900 113		45	21.0	6.8	50	1100	included in the KIT			S	A	--	E1	D1	--	V	75	B	
Kia Sorento	06/02-07/06			345 020 600 001		90	24.0	14.1	150	2800	300 061 300 107			--	C2	--	E1	--	--	V		B		
					345 021 600 001	→ 	90	26.0	14.9	150	2800	300 061 300 113			--	C2	--	--	--	V		B		











Kia

Kia Sportage	08/10-		345 087 600 001		90	23.0	11.0	80	2400	345 079 300 113				S	A	--	E	D1	L1	V	90	B	
			345 079 600 001		60	25.0	10.6	80	2300														
	KIT			345 087 900 113		90	25.0	11.0	80	2400	included in the KIT				S	A	--	E	D1	L1	V	90	B
				345 079 900 113		60	27.0	10.6	80	2300													
Kia Venga	03/10-		345 069 600 001		90	20.0	7.6	60	1300	346 064 300 107				S	A	--	E1	--	--	V	75	B	
			345 070 600 001		90	21.0	7.6	60	1300	346 064 300 113				S	A	--	E1	D1	--	V	75	B	







Lancia Delta For vehicles 1,4 Turbojet 120 and 140 HP please order separately supports for the exhaust at Lancia dealers, ref. 51809585 and 51823864.	09/08-			306 275 600 001		60	23.0	7.7	90	1300		306 640 300 113			S	FRE	--	E	D1	L1	V	120	L																						
Lancia Musa	10/04-12			306 353 600 001		180	18.0	6.8	80	1200		306 240 300 107	→	-09/07	S	FRE	--	E	--	--	H	45	B																						
												306 240 300 113	→	-09/07	S	FRE	--	E	D1	L1	H	45	B																						
												306 353 300 113		10/07-	S	FRE	--	E	D	--	V	120	B																						
Lancia Phedra	09/02-			315 098 600 001		75	19.8	10.8	100	1900		304 400 300 107		10/05-	S	CAN	C1	E	--	--	H	105	B																						
												304 400 300 113			S	CAN	C1	E	D	L1	H	105	B																						
												315 097 600 001			75	22.0	10.8	100	1900	315 097 300 107	→	-09/05	S	FRE	--	E	--	--	H	45	B														
												315 097 300 113			315 097 300 113	→	-09/05	S	FRE	--	E	D1	L1	H	45	B																			
Lancia Phedra	10/05-	KIT		315 098 900 113		75	21.8	10.8	100	1900		included in the KIT			S	CAN	C1	E	D	L1	H	105	B																						
																								KIT		315 097 900 113		75	24.0	10.8	100	1900													
Lancia Thema	11/11-			306 390 600 001		90	18.0	11.8	80	2000		300 078 300 113				--	FRE	--	--	D1	L1	V		B																					
																										306 391 600 001		90	18.0	11.8	80	2000													
																									KIT		306 390 900 113		90	20.0	11.8	80	2000	included in the KIT			--	FRE	--	--	D1	L1	V		B
																									KIT		306 391 900 113		90	20.0	11.8	80	2000												
Lancia Voyager	11/11-			342 124 600 001		120	31.0	10.0	85	1700		300 078 300 113			--	FRE	--	--	D1	L1	V		B																						
																									342 125 600 001		120	31.0	10.4	85	1700														



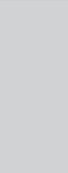









Lancia

Lancia Ypsilon	10/03-12/06		306 246 600 001	→		180	18.0	6.6	75	1200		306 540 300 113	→		S	FRE	--	E	D	--	V	105	L
Lancia Ypsilon	01/07-07/11		306 321 600 001	→		180	18.0	6.9	75	1200		306 540 300 113	→		S	FRE	--	E	D	--	V	105	L
Lancia Ypsilon	07/11-	 	306 385 600 001			60	19.0	6.1	70	1000		306 383 300 113			S	FRE	--		D1	--	V	105	
Lancia Zeta	09/94-08/02		315 072 600 001	→		60	16.4	10.9	100	2000		300 060 300 107			--	C2	--	E1	--	--	H	45	B
											300 060 300 113			--	C2	--	E1	D1	L1	H	45	B	





















Land Rover Defender 110/131 Towing bracket for towball or automatic bolt coupling, suitable towball 329062600001 or 20 mm lower: 329042600001	09/98-		323 049 600 001			90	10.3	17.2	150	3500		323 048 300 107 →		S	C2	--	E1	--	--	H	45	B	
												323 048 300 113											S
Land Rover Defender 90 Towing bracket for towball or automatic bolt coupling, suitable towball 329062600001 or 20 mm lower: 329042600001	09/98-		323 048 600 001			90	10.3	17.2	150	3500		323 048 300 107 →		S	C2	--	E1	--	--	H	45	B	
												323 048 300 113											S
Land Rover Discovery Sport for vehicles without spare wheel	02/15-		323 141 600 001																				
Land Rover Discovery Sport for vehicles with spare wheel and 7 seats	02/15-		323 142 600 001																				
Land Rover Freelander	98-05/07		323 040 600 001			90	17.4	11.8	140	2500		300 096 300 157		--	--	--	E1	--	--	V	30	B	
												300 096 300 163											--
			323 085 600 001 →			90	17.8	11.8	140	2500		323 040 300 113 →		S	C2	--	E1	D1	L1	H	45	B	
Land Rover Freelander 2	05/07-		323 078 600 001			105	18.5	11.0	150	2000		323 410 300 113	-10/12	S	FRE	--	E2	D	L1	H	60	B	
												323 411 300 113											10/12-
Range-Rover Evoque	09/11-		323 101 600 001			90	18.0	10.0	100	1800		323 102 300 113		S	C2	--	E1	D	L	H	30	B	
																							
		KIT		323 101 900 113			90	20.0	10.0	100	1800		included in the KIT		S	C2	--	E1	D	L	H	30	B
			KIT		323 102 900 113			90	22.0	10.0	100	1800											
Range Rover L322 (with BMW-motor) cross bar only	02/02-05/05		323 064 600 001			150	32.5	16.4	150	3500		323 064 300 113	-09/09	S	FRE	--	E	D	L	H	30	B	





























Land Rover

Range Rover L322 Mounting tube inc. detachable towball, storage bowl and fitting material (only in connection with 323064600001 or 323074600001)	02/02-12		323 063 600 001		150	15.0	16.4	150	3500	323 064 300 113	-09/09	S	FRE	--	E	D	L	H	30	B
			323 062 600 001		150	15.0	16.4	150	3500	323 074 300 113	09/09- chassis no. AA ...	S		C	E	D	L	H	15	B
Range Rover L322 (with Jaguar-motor) cross bar only Vogue = visible cut	05/05-12		323 074 600 001		150	33.0	16.4	150	3500	323 064 300 113	-09/09	S	FRE	--	E	D	L	H	30	B
										323 074 300 113	09/09- chassis no. AA ...	S		C	E	D	L	H	15	B
Range-Rover L405	01/13-		323 107 600 001		120		16.6	200	3500	323 107 300 113		S	C2	C	E2	D	L	H	15	B
Range Rover Sport The vehicle already has a built in towball receptor. Please order additional equipment with Land Rover dealers.	03/05-10/13																			
Range Rover Sport L 494	10/13-		323 121 600 001		120	0.0	16.6	200	3500	323 107 300 113		S	C2	C	E2	D	L	H	15	B





















Lexus IS 250/220d	06-06/13			335 355 600 001		90	26.4	9.0	75	1500		300 210 300 113			--	A	--	E1	D1	L1	V	90	B
Lexus NX	10/14-			335 467 600 001								335 467 300 113			S	FRE	--	E2	D	L1	H	90	B
Lexus RX 300 / 350 / 400 / 400 h	03/03-09			335 305 600 001		120	45.0	11.8	80	2000		335 357 300 107	335 357 300 113		S	FRE	--	E2	--	--	V	105	B
Lexus RX 350 / 450 h exc. vehicles with height control	05/09-			335 357 600 001		90	38.0	11.8	85	2100		335 357 300 107	335 357 300 113		S	FRE	--	E2	--	--	V	105	B
		KIT		335 357 900 113		90	40.0	11.8	85	2100		included in the KIT			S	FRE	--	E2	D	L1	V	105	B
Lexus RX 350 / 450 h for vehicles with height control	05/09-			335 358 600 001		90	38.0	11.9	85	2100		335 357 300 107	335 357 300 113		S	FRE	--	E2	--	--	V	105	B
		KIT		335 358 900 113		90	40.0	11.9	85	2100		included in the KIT			S	FRE	--	E2	D	L1	V	105	B

























Mazda

Mazda 2 inc. vehicles with sport optics package	10/07-02/15			343 047 600 001		60	18.5	7.0	50	1100		343 060 300 113			S	FRE	--	E	D1	--	H	45	L
Mazda 2	10/07-02/15			343 072 600 001			19.0	7.0	50			343 060 300 113			S	FRE	--	E	D1	--	H	45	L
Mazda 2	02/15-			343 075 600 001																			
				343 076 600 001																			
Mazda 3 Hatchback exc. MPS (260 HP)	10/03-10/13			343 038 600 001		90	21.5	8.7	75	1590		300 072 300 107 300 072 300 113 343 066 300 107 343 066 300 113	-03/09 -03/09 03/09- 03/09-	-- -- S S	FRE FRE A A	-- -- -- --	-- -- -- D1	-- D1 -- --	-- L1 -- --	V V V V		75 75	B B B B
Mazda 3 Hatchback exc. MPS (260 HP)	03/09-10/13	KIT		343 038 900 113		60	23.5	8.7	75	1590		included in the KIT	03/09-	S	A	--	--	D1	--	V	75	B	
Mazda 3 Hatchback	10/13-			343 073 600 001		90	19.0	9.2	75	1800		343 074 300 113			S	A	--	E2	D1	L1		90	B
				343 074 600 001		90	21.0	9.2	75	1800													
		KIT		343 073 900 113		90	20.0	9.2	75	1800		included in the KIT			S	A	--	E2	D1	L1		90	B
		KIT		343 074 900 113		90	22.0	9.2	75	1800													
Mazda 3 Notchback exc. MPS (260 HP)	10/03-03/09			343 038 600 001		90	21.5	8.7	75	1590		300 072 300 113			--	FRE	--	--	D1	L1	V		B
Mazda 3 Notchback	10/13-			343 080 600 001		90	24.0	9.2	75	1800		343 074 300 113			S	A	--	E2	D1	L1		90	B
		KIT		343 080 900 113		90	25.0	9.2	75	1800		included in the KIT			S	A	--	E2	D1	L1		90	B



Mazda 5 -12/07: The fog tail light must be moved. Please order separately reversion kit, order no. CC29-V7-250 at Mazda dealers. inc. facelift 01/08-	06/05-10/10			343 060 600 001		90	21.0	9.3	75	1600		343 660 300 113				S	FRE	--	--	D1	L1	V	105	B
				343 040 600 001		90	22.0	9.3	75	1600														
	KIT			343 040 900 113		90	24.0	9.3	75	1600		included in the KIT					S	FRE	--	--	D1	L1	V	105
Mazda 5	10/10-			343 064 600 001		60	19.0	9.8	75	1700		343 063 300 113				S	A	--	E1	D1	L1	V	105	B
				343 063 600 001		60	19.0	9.8	75	1700														
Mazda 6 Hatchback/Saloon	03/08-02/13			343 048 600 001		120	22.0	9.8	75	1800		343 400 300 107				S	A	--	E2	--	--	V	90	B
				343 058 600 001		120	26.0	9.8	75	1800		343 400 300 113				S	A	--	E2	D1	L1	V	90	B
	KIT			343 048 900 113		120	24.0	9.8	75	1800		included in the KIT				S	A	--	E2	D1	L1	V	90	B
	KIT			343 058 900 113		120	28.0	9.8	75	1800														
Mazda 6 Hatchback/Saloon	02/13-			343 077 600 001		90	24.0	10.1	75	1800		343 071 300 113				S	A	--	E	D	L1	V	90	B
				343 078 600 001		90	26.0	10.1	75	1800														
	KIT			343 077 900 113		90	26.0	10.1	75	1800		included in the KIT				S	A	--	E	D	L1	V	90	B
	KIT			343 078 900 113		90	28.0	10.1	75	1800														
Mazda 6 Estate exc. MPS (260 HP)	07/02-04/08			343 036 600 001		150	20.0	9.4	75	1800		343 400 300 107				S	A	--	E2	--	--	V	90	B
												343 400 300 113				S	A	--	E2	D1	L1	V	90	B





















Mazda

Mazda 6 Estate exc. MPS (260 HP) For facelift (from approx. middle of 2006) a larger cutout is necessary.	07/02-04/08		343 044 600 001 → 	150	20.0	9.4	75	1800	343 400 300 107			S	A	--	E2	--	--	V	90	B	
			343 400 300 113	S	A	--	E2	D1				L1	V	90	B						
Mazda 6 Estate	03/08-02/13		343 048 600 001 	120	22.0	9.8	75	1800	343 400 300 107			S	A	--	E2	--	--	V	90	B	
			343 058 600 001 	120	26.0	9.8	75	1800				343 400 300 113	S	A	--	E2	D1	L1	V	90	B
		KIT		343 048 900 113 	120	24.0	9.8	75	1800	included in the KIT			S	A	--	E2	D1	L1	V	90	B
			KIT		343 058 900 113 	120	28.0	9.8	75				1800								
Mazda 6 Estate	02/13-		343 070 600 001 	90	24.0	10.1	75	1800	343 071 300 113			S	A	--	E	D	L1	V	90	B	
			343 071 600 001 	90	26.0	10.1	75	1800													
		KIT		343 070 900 113 	90	26.0	10.1	75	1800	included in the KIT			S	A	--	E	D	L1	V	90	B
			KIT		343 071 900 113 	90	28.0	10.1	75				1800								
Mazda 6 Saloon exc. MPS (260 HP)	06/02-03/08		343 034 600 001 	150	20.3	9.4	75	1800	343 400 300 107			S	A	--	E2	--	--	V	90	B	
			343 400 300 113	S	A	--	E2	D1				L1	V	90	B						
Mazda 6 Saloon exc. MPS (260 HP) For facelift (from approx. middle of 2006) a larger cutout is necessary.	06/02-03/08		343 043 600 001 → 	150	20.0	9.4	75	1800	343 400 300 107			S	A	--	E2	--	--	V	90	B	
			343 400 300 113	S	A	--	E2	D1				L1	V	90	B						















Mazda CX5	04/12-			343 053 600 001		90	22.0	10.8	100	2100		343 056 300 107			S	A	--	E2	--	--	V	90	B
				343 056 600 001		90	25.0	10.8	100	2100		343 056 300 113			S	A	--	E2	D	L1	V	90	B
		KIT		343 053 900 113		90	24.0	10.8	100	2100		included in the KIT			S	A	--	E2	D	L1	V	90	B
		KIT		343 056 900 113		90	27.0	10.8	100	2100						S	A	--	E2	D	L1	V	90
Mazda CX7	10/07-			343 066 600 001		90	22.0	10.8	85	2000		343 400 300 107			S	A	--	E2	--	--	V	90	B
				343 067 600 001		90	25.0	10.8	85	2000		343 400 300 113			S	A	--	E2	D1	L1	V	90	B
		KIT		343 066 900 113		90	24.0	10.8	85	2000		included in the KIT			S	A	--	E2	D1	L1	V	90	B
		KIT		343 067 900 113		90	27.0	10.8	85	2000						S	A	--	E2	D1	L1	V	90
Mazda Serie B	-12/06			307 372 600 001		60	32.0	14.1	100	2800		300 052 300 107			--	FRE	--	E1	--	--	V		B
												300 052 300 113			--	FRE	--	E1	D1	--	V		B
Mazda Pickup BT50 4 WD	12/06-			307 376 600 001		60	32.0	14.9	150	3000		307 376 300 113			S	C2	--	E1	D	--	V		B
Mazda Pickup BT50	06/12-			307 443 600 001		90	41.0	17.2	200	3500		307 443 300 113											B
		KIT		307 443 900 113		90	43.0	17.2	200	3500		included in the KIT											
Mazda Premacy	99-06/05			343 033 600 001	 	120	16.0	8.4	80	1600		300 072 300 107			--	FRE	--	--	--	--	V		B
												300 072 300 113			--	FRE	--	--	D1	L1	V		B



















Mazda



















Mazda Tribute year of construction: 2005	03/04-		307 339 600 001	→ 	150	20.0	10.0	80	2000		300 072 300 107			--	FRE	--	--	--	--	V		B
				307 340 600 001	→ 	150	21.0	10.0	80	2000		300 072 300 113			--	FRE	--	--	D1	L1	V	

Mercedes A Class W168 inc. vehicles with facelift and vehicles with long wheelbase from approx. 04/01 exc. AMG	97-09/04			313 185 600 001		120	13.0	6.2	50	1000		313 120 300 107			S	FRE	--	E	--	--	H	45	L
				313 183 600 001		120	14.5	6.2	50	1000		313 120 300 113			S	FRE	--	E	D	L1	H	45	L
	KIT		313 185 900 113		120	15.0	6.2	50	1000		included in the KIT			S	FRE	--	E	D	L1	H	45	L	
Mercedes A Class W169	09/04-			313 171 600 001		120	18.0	8.5	80	1500		313 122 300 113			S	CAN	C	E	D1	--	V	90	L
				313 231 600 001		120	18.0	8.5	80	1500		313 231 300 107			S	CAN	C	E	--	--	V	90	B
	KIT		313 171 900 113		120	19.0	8.5	80	1500		included in the KIT			S	CAN	C	E	D1	L1	V	90	B	
	KIT		313 231 900 113		120	19.5	8.5	80	1500						S	CAN	C	E	D1	L1	V	90	B
Mercedes A Class W176 exc. vehicles with AMG look.	09/12-	KIT		313 386 600 001		60	29.5	9.2	80	1500		included in the KIT			S	CAN	C	E	D	L		105	B
Mercedes A Class W176 exc. vehicles with AMG look	09/12-			313 396 600 001		60	23.0	9.2	80	1500		313 398 300 107			S	CAN	C	E	--	--	V	105	B
				313 398 600 001		60	25.0	9.2	80	1500		313 398 300 113			S	CAN	C	E	D	L	V	105	B
	KIT		313 396 900 113		60	25.0	9.2	80	1900		included in the KIT			S	CAN	C	E	D	L	V	105	B	
	KIT		313 398 900 113		60	27.0	9.2	80	1500						S	CAN	C	E	D	L	V	105	B

















Mercedes-Benz













Mercedes Atego towing bracket with integral underrun guard (supply in pairs only: 313404600002 + 313404600003) Please check tolerances when mounting (measures see "Universal HGV towing brackets). swap system or automatic bolt coupling permitted suitable towball: 329060600001	97-		313 404 600 001			90	61.0	25.1	150	3500		300 201 300 113	for 12V vehicles	--	A	--	E1	D1	--	V				B
Mercedes B Class W245	06/05-		313 171 600 001			120	18.0	8.5	80	1500		313 122 300 113		S	CAN	C	E	D1	--	V	90		L	
			313 231 600 001			120	18.0	8.5	80	1500		313 231 300 107		S	CAN	C	E	--	--	V	90			B
		KIT 	313 171 900 113			120	19.0	8.5	80	1500		included in the KIT		S	CAN	C	E	D1	L1	V	90			B
		KIT 	313 231 900 113			120	19.5	8.5	80	1500					S	CAN	C	E	D	L	V	105		
Mercedes B Class W246 exc. vehicles with AMG look	11/11-	KIT 	313 386 600 001			60	29.5	9.2	80	1500		included in the KIT		S	CAN	C	E	D	L	V	105			B
Mercedes B Class W246 exc. vehicles with AMG look	11/11-		313 396 600 001			60	23.0	9.2	80	1500		313 398 300 107		S	CAN	C	E	--	--	V	105			B
			313 398 600 001			60	25.0	9.2	80	1500		313 398 300 113		S	CAN	C	E	D	L	V	105			B
		KIT 	313 396 900 113			60	25.0	9.2	80	1900		included in the KIT		S	CAN	C	E	D	L	V	105			B
		KIT 	313 398 900 113			60	27.0	9.2	80	1500					S	CAN	C	E	D	L	V	105		

Mercedes C Class Coupé C204 + C204 AMG style	06/11-		313 214 600 001		>150	21.0	10.2	75	1900	313 212 300 113			S	CAN	C	E	D	L	H	45	B
			313 438 600 001		120	23.0	10.2	75	1900	313 361 300 107			S	CAN	C	E	--	--	H	45	B
	KIT		313 389 900 113		>150	23.0	10.2	75	1900	included in the KIT			S	CAN	C	E	D1	L1	H	45	B
		KIT		313 211 900 113		>150	25.0	10.2	75		1900			S	CAN	C	E	D1	L1	H	45
Mercedes C Class Estate S202	05/96-05/01		313 420 600 001		120	20.0	9.6	75	1700	313 082 300 113			S	FRE	--	E	D	--	H	90	B
			313 082 600 001		>150	17.2	9.1	75	1700				S	FRE	--	E	D	--	H	90	B
Mercedes C Class Estate S203 with steel springs exc. Sport Coupé, CLK from 05/02, AMG and 4x4	06/01-09/07		313 166 600 001		>150	22.0	9.1	75	1600	313 168 300 107			S	CAN	C	E	--	--	H	60	B
			313 167 600 001		>150	23.8	9.1	75	1600	313 168 300 113			S	CAN	C	E	D	--	H	60	B
	KIT		313 166 900 113		>150	24.0	9.1	75	1600	included in the KIT			S	CAN	C	E	D	--	H	60	B
		KIT		313 167 900 113		>150	25.5	9.1	75		1600			S	CAN	C	E	D	--	H	60
Mercedes C Class Estate S204 exc. vehicles with height control, exc. AMG & sport bumpers	09/07-		313 214 600 001		>150	21.0	10.2	75	1900	313 210 300 107	→	-07/09	S	CAN	C	E	--	--	H	45	B
			313 438 600 001		120	23.0	10.2	75	1900	313 210 300 113		-07/09	S	CAN	C	E	D	L	H	45	B
										313 212 300 113		07/09-	S	CAN	C	E	D	L	H	45	B
										313 361 300 107		07/09-	S	CAN	C	E	--	--	H	45	B



















Mercedes C Class Saloon W203 with steel springs exc. Sport Coupé, CLK from 05/02, AMG	06/00-03/07			313 166 600 001			>150	22.0	9.1	75	1600		313 168 300 107			S	CAN	C	E	--	--	H	60	B
				313 167 600 001			>150	23.8	9.1	75	1600		313 168 300 113			S	CAN	C	E	D	--	H	60	B
	KIT		313 166 900 113			>150	24.0	9.1	75	1600		included in the KIT			S	CAN	C	E	D	--	H	60	B	
	KIT		313 167 900 113			>150	25.5	9.1	75	1600						S	CAN	C	E	D	--	H	60	B
Mercedes C Class Saloon W204 exc. vehicles with height control exc. AMG & sport bumpers, vehicles with AMG look	03/07-			313 214 600 001			>150	21.0	10.2	75	1900		313 210 300 107	→	-07/09	S	CAN	C	E	--	--	H	45	B
				313 438 600 001			120	23.0	10.2	75	1900		313 210 300 113		-07/09	S	CAN	C	E	D	L	H	45	B
													313 212 300 113		07/09-	S	CAN	C	E	D	L	H	45	B
													313 361 300 107		07/09-	S	CAN	C	E	--	--	H	45	B
Mercedes C Class Saloon W204 inc. vehicles with height control, exc. AMG & sport bumpers	03/07-			313 439 600 001			120	23.0	10.2	75	1900		313 210 300 107	→	-07/09	S	CAN	C	E	--	--	H	45	B
												313 210 300 113		-07/09	S	CAN	C	E	D	L	H	45	B	
													313 212 300 113		07/09-	S	CAN	C	E	D	L	H	45	B
													313 361 300 107		07/09-	S	CAN	C	E	--	--	H	45	B
Mercedes C Class Saloon W204 exc. vehicles with height control exc. AMG & sport bumpers, vehicles with AMG look	03/07-07/09	KIT		313 214 900 113			>150	23.0	10.2	75	1900		included in the KIT		-07/09	S	CAN	C	E	D	L	H	45	B
		KIT		313 315 900 113			>150	25.0	10.2	75	1900													
Mercedes C Class Saloon W204 exc. vehicles with height control exc. AMG & sport bumpers, vehicles with AMG look	07/09-	KIT		313 389 900 113			>150	23.0	10.2	75	1900		included in the KIT			S	CAN	C	E	D1	L1	H	45	B
		KIT		313 211 900 113			>150	25.0	10.2	75	1900													











Mercedes-Benz

Mercedes C Class Saloon W205 inc. AMG look	03/14-		313 431 600 001		21.0	10.5	85	1900	313 432 300 107	S	CAN	C	E	--	--	H	45	L	
			313 432 600 001		23.0	10.5	85	1900	313 432 300 113	S	CAN	C	E	D	L	H	45	L	
	KIT		313 431 900 113		23.0	10.5	85	1900	included in the KIT	S	CAN	C	E	D	L	H	45	L	
	KIT		313 432 900 113		24.0	10.5	85	1900		S	CAN	C	E	D	L	H	45	L	
Mercedes CLA C117 incl. Vehicles with AMG look	04/13-		313 396 600 001		60	23.0	9.2	80	1500	313 398 300 107	S	CAN	C	E	--	--	V	105	B
			313 400 600 001		60	24.5	9.2	80	1900	313 398 300 113	S	CAN	C	E	D	L	V	105	B
			313 503 600 001		60	24.5	9.2	80	1900		S	CAN	C	E	D	L	V	105	B
	KIT		313 396 900 113	60	25.0	9.2	80	1900	included in the KIT	S	CAN	C	E	D	L	V	105	B	
KIT		313 400 900 113	60	26.0	9.2	80	1900	S		CAN	C	E	D	L	V	105	B		
Mercedes CLC is not permitted to tow by manufacturer.																			
Mercedes CLK CL209 exc. convertible, exc. AMG	05/02-		313 200 600 001		>150	23.0	10.3	75	1500	313 168 300 107	S	CAN	C	E	--	--	H	60	B
										313 168 300 113	S	CAN	C	E	D	--	H	60	B















Mercedes CLS Shooting Brake exc. vehicles with AMG look	12-			313 371 600 001			150	26.0	11.5	84	2100		313 361 300 107			S	CAN	C	E	--	--	H	45	B
				313 373 600 001			150	27.0	11.5	84	2100		313 361 300 113			S	CAN	C	E	D1	L1	H	45	B
		KIT		313 371 900 113			150	28.0	11.5	84	2100		included in the KIT			S	CAN	C	E	D1	L1	H	45	B
		KIT		313 373 900 113			150	29.0	11.5	84	2100						S	CAN	C	E	D1	L1	H	45
Mercedes Citan length = 4321 + 4705 mm	10/12-			316 268 600 001			60	23.0	8.2	75	1350		316 353 300 107			S	FRE	--	--	--	H	60	L	
				316 269 600 001			60	23.0	8.2	75	1350		316 353 300 113			S	FRE	--	D1	L1	H	60	L	
		KIT		316 352 900 113			60	25.0	8.2	75	1350		included in the KIT			S	FRE	--	D1	L1	H	60	L	
		KIT		316 353 900 113			60	25.0	8.2	75	1350						S	FRE	--	D1	L1	H	60	L
Mercedes Citan length = 3937 mm	10/12-			316 316 600 001			90	20.0	7.2	75	1100		316 353 300 107			S	FRE	--	--	--	H	60	L	
													316 353 300 113			S	FRE	--	D1	L1	H	60	L	
Mercedes CLK Coupé/ Convertible C208 and convertible CLK exc. 430 CLK and AMG-vehicles	06/97-05/02			313 082 600 001			>150	17.2	9.1	75	1700		313 116 300 107			S	FRE	--	E	--	--	V	120	L
													313 116 300 113			S	FRE	--	E	D	--	V	120	L
Mercedes CLK Coupé/ Convertible C208 exc. 430 CLK, AMG-vehicles	06/97-05/02			313 420 600 001			120	20.0	9.6	75	1700		313 116 300 107			S	FRE	--	E	--	--	V	120	L
													313 116 300 113			S	FRE	--	E	D	--	V	120	L
Mercedes C Class Sport Coupé CL203 exc. AMG-vehicles, CLC 05/08- Cover for cutout offered by Mercedes is not suitable.	01-05/08			313 189 600 001			>150	23.0	8.8	100	1500		313 168 300 107			S	CAN	C	E	--	--	H	60	B
													313 168 300 113			S	CAN	C	E	D	--	H	60	B

















Mercedes-Benz

Mercedes E Class 200-400 E W/C 124 saloon, Coupé and convertible exc. 500 E, Sportline and AMG- vehicles	01/85-05/95		313 061 600 001 →		>150	22.4	10.3	75	1900		313 061 300 107 →									S	C2	--	E1	--	--	V	90	L		
																				313 061 300 113 →	S	C2	--	E1	--	L1	V	90	L	
Mercedes E Class 200T-320TE S124	01/86-04/96		313 066 600 001 →		150	16.9	10.8	75	2100		313 067 300 107 →									S	C2	--	E1	--	--	V	90	L		
Mercedes E Class Convertible C207 exc. AMG vehicles, exc. vehicles with AMG look	03/10-		313 214 600 001		>150	21.0	10.2	75	1900		313 212 300 113										S	CAN	C	E	D	L	H	45	B	
																						313 438 600 001		120	23.0	10.2	75	1900		313 361 300 107
		KIT		313 389 900 113		>150	23.0	10.2	75	1900		included in the KIT																		
		KIT		313 211 900 113		>150	25.0	10.2	75	1900																				
Mercedes E Class Coupé C207 exc. AMG vehicles, exc. vehicles with AMG look	05/09-		313 214 600 001		>150	21.0	10.2	75	1900		313 212 300 113										S	CAN	C	E	D	L	H	45	B	
																						313 438 600 001		120	23.0	10.2	75	1900		313 361 300 107
		KIT		313 389 900 113		>150	23.0	10.2	75	1900		included in the KIT																		
		KIT		313 211 900 113		>150	25.0	10.2	75	1900																				
Mercedes E Class Estate S210 exc. AMG-vehicles Vehicles with 300 TD motor and air conditioning: Please check the operating instructions of the vehicle before fitting the towbar.	05/96-03		313 121 600 001		150	17.1	11.5	84	2200		313 116 300 107									S	FRE	--	E	--	--	V	120	L		
																				313 116 300 113	S	FRE	--	E	D	--	V	120	L	









Mercedes E Class Estate S211 exc. AMG inc. 4-Matic	03-09/09			313 203 600 001			150	23.5	11.5	130	2200		313 196 300 107			S	CAN	C	E	--	--	H	60	B
				313 204 600 001			150	23.0	11.5	130	2200		313 196 300 113			S	CAN	C	E	D	--	H	60	B
		KIT		313 203 900 113			150	25.5	11.5	130	2200		included in the KIT			S	CAN	C	E	D	--	H	60	B
		KIT		313 204 900 113			150	25.0	11.5	130	2200						S	CAN	C	E	D	--	H	60
Mercedes E Class Estate S212 inc. AMG styling package	09/09-			313 371 600 001			150	26.0	11.5	84	2100		313 212 300 113			S	CAN	C	E	D	L	H	45	B
				313 373 600 001			150	27.0	11.5	84	2100		313 361 300 107			S	CAN	C	E	--	--	H	45	B
		KIT		313 371 900 113			150	28.0	11.5	84	2100		included in the KIT			S	CAN	C	E	D1	L1	H	45	B
		KIT		313 373 900 113			150	29.0	11.5	84	2100						S	CAN	C	E	D1	L1	H	45
Mercedes E Class Saloon W210 exc. AMG-vehicles Vehicles with 300 TD motor and air conditioning: Please check the operating instructions of the vehicle before fitting the towbar.	06/95-03/02			313 161 600 001			150	18.5	10.8	75	2000		313 116 300 107			S	FRE	--	E	--	--	V	120	L
				313 160 600 001			150	20.4	10.8	75	2000		313 116 300 113			S	FRE	--	E	D	--	V	120	L
		KIT		313 160 900 113			150	23.0	10.8	75	2000		included in the KIT			S	FRE	--	E	D	--	V	120	L



Mercedes-Benz

Mercedes E Class Saloon W211 exc. AMG, inc. 4-Matic If there are no reinforcements right and left in the boot, it is necessary to mount them. You can buy them at the DC dealer, DC no. A 211 639 0143 and A 211 639 0443. With this reinforcements the coverings of the sides don't fit anymore. You could buy others at the DC dealer, e.g. A 211 690 9425 / 9825. The supercharger of the cooling must have a power of 600 W. The superchargers A 001 500 4493 and A 211 500 0693 fulfil this requirement.	03/02-09		313 194 600 001			150	23.5	11.0	80	2000								S	CAN	C	E	--	--	H	60	B		
			313 195 600 001			150	24.5	11.0	80	2000									S	CAN	C	E	D	--	H	60	B	
		KIT		313 194 900 113			150	25.5	11.0	80	2000									S	CAN	C	E	D	--	H	60	B
		KIT		313 195 900 113			150	25.0	11.0	80	2000				included in the KIT					S	CAN	C	E	D	--	H	60	B
Mercedes E Class Saloon W212	03/09-		313 360 600 001			90	26.0	11.4	84	2100									S	CAN	C	E	D	L	H	45	B	
			313 361 600 001			90	26.0	11.4	84	2100										S	CAN	C	E	--	--	H	45	B
		KIT		313 360 900 113			90	28.0	11.4	84	2100									S	CAN	C	E	D1	L1	H	45	B
		KIT		313 361 900 113			90	28.0	11.4	84	2100				included in the KIT					S	CAN	C	E	D1	L1	H	45	B
Mercedes G Class only for vehicles with 2-parts rear bumper	02/90-		313 320 600 001			60	12.0	17.2	140	3500									--	A	--	--	--	--	V		B	
																				--	A	--	E1	D1	L1	V	90	B
Mercedes GL Class X164/X166 inc. 8 cylinder diesel exc. vehicles with AMG look For vehicles with AdBlue tank please order: holder 913406609103	09/06-		313 421 600 001			120	38.0	16.5	135	3500									S	CAN	C	E	D	L	H	45	B	
																				S	CAN	C1	E	D	L1	H	60	B
Mercedes GLA X156 exc. vehicles with AMG look	03/14-		313 401 600 001			60		10.2	80	1900									S	CAN	C	E	--	--	V	105	B	
			313 400 600 001				60	24.5	9.2	80	1900									S	CAN	C	E	D	L	V	105	B
		KIT		313 401 900 113			60		10.2	80	1900				included in the KIT					S	CAN	C	E	D	L	V	105	B



Mercedes GLA X156 inc. vehicles with AMG look (bumper cut necessary)	03/14-			313 503 600 001			60	24.5	9.2	80	1900		313 398 300 107			S	CAN	C	E	--	--	V	105	B	
														313 398 300 113			S	CAN	C	E	D	L	V	105	B
		KIT		313 400 900 113			60	26.0	9.2	80	1900		included in the KIT			S	CAN	C	E	D	L	V	105	B	
Mercedes GLK X204	10/08-			313 433 600 001			90	22.0	12.8	100	2500		313 210 300 107	→	-07/09	S	CAN	C	E	--	--	H	45	B	
				313 434 600 001		90	23.0	12.8	100	2500		313 210 300 113		-07/09	S	CAN	C	E	D	L	H	45	B		
												313 212 300 113		07/09-	S	CAN	C	E	D	L	H	45	B		
												313 361 300 107		07/09-	S	CAN	C	E	--	--	H	45	B		
Mercedes GLK X204	07/09-	KIT		313 433 900 113		90	24.0	12.8	100	2500		included in the KIT			S	CAN	C	E	D1	L1	H	45	B		
		KIT		313 434 900 113		90	25.0	12.8	100	2500															
Mercedes M Class W163 exc. vehicles with spare wheel on the tailgate	98-07/05			313 134 600 001		90	13.6	16.0	150	3500		313 134 300 113			S	FRE	--	E	D	--	H	45	B		
Mercedes M Class W163 exc. vehicles with spare wheel on the tailgate For vehicles -2000 we recommand to order bumper with cutout and cover of the vehicles 2000-2002 at Mercedes-Benz dealers.	98-07/05			313 179 600 001		90	15.0	16.0	150	3500		313 134 300 113			S	FRE	--	E	D	--	H	45	B		
Mercedes M Class W164	07/05-			313 341 600 001		120	38.0	16.0	135	3500		313 138 300 113		Please order separately control unit + relay at DC dealers.	S	CAN	C	E	D	L	H	45	B		
				313 340 600 001		120	39.0	16.0	135	3500															











Mercedes-Benz

Mercedes M Class W166 exc. vehicles with AMG look	11/11-		313 405 600 001		90	39.0	16.8	140	3500	313 430 300 113			S	CAN	C1	E	D	L1	H	60	B		
			313 406 600 001		90	40.0	16.8	140	3500														
			KIT		313 406 900 113		90	42.0	16.8													140	3500
Mercedes R Class W251	02/06-		313 222 600 001		>150	34.0	12.5	85	2100	313 138 300 113		Please order separately control unit + relay at DC dealers.	S	CAN	C	E	D	L	H	45	B		
Mercedes SLK is not permitted to tow by manufacturer.																							
Mercedes Sprinter The program for Mercedes Sprinter can be found in the appendix.	03/96-03/06																						
Mercedes Sprinter Van types 411-424 and 509-524 Vehicles with 5,0 t max. total weight, reduction to 4,6 t max. total weight is possible. wheelbase: 3665 mm For vehicles with integrated step device in the bumper the middle part of the outer bumper must be exchanged (Please order separately at Mercedes dealers.). towball: 329059600001 (order separately) Step DC-IR A906 520 0531 is not utilisable. Utilisable step: 313285600001 or 313440600001	04/06-		313 272 600 001		120	21.0	20.2	150	3500	313 105 300 107		-12/14 for vehicles without preparation	S	CAN	C	E	--	--	V	90	B		
			313 105 300 113										-12/14 for vehicles without preparation	S	CAN	C	E	D1	--	V	90	B	
			313 107 300 107										01/15- for vehicles without preparation	S									
			313 107 300 113										01/15- for vehicles without preparation	S									
			313 108 300 113											01/15- for vehicles with preparation	S								
												-12/14 vehicles with preparation	S	CAN	C	E	D	--	H	45	B		















Mercedes Sprinter Van types 411-424 and 509-524 Vehicles with 5,0 t max. total weight, reduction to 4,6 t max. total weight is possible. wheelbase: 4325 mm For vehicles with integrated step device in the bumper the middle part of the outer bumper must be exchanged (Please order separately at Mercedes dealers.). towball: 329059600001 (order seperately) Step DC-IR A906 520 0531 is not utilisable. Utilisable step: 313285600001 or 313440600001	04/06-		313 273 600 001			120	21.0	20.2	150	3500		313 105 300 107	-12/14 for vehicles without preparation	S	CAN	C	E	--	--	V	90	B	
												313 105 300 113	-12/14 for vehicles without preparation	S	CAN	C	E	D1	--	V	90	B	
												313 107 300 107	01/15- for vehicles without preparation	S									
												313 107 300 113	01/15- for vehicles without preparation	S									
												313 108 300 113	01/15- for vehicles with preparation	S									
												321 106 300 113	-12/14 vehicles with preparation	S	CAN	C	E	D	--	H	45	B	
Mercedes Sprinter Van types 209-224 and 309-324 Vehicles with 3,0 and 3,5 t max. total weight, increase to 3,8 t max. total weight is possible For vehicles with integrated step device in the bumper the middle part of the outer bumper must be exchanged (Please order separately at Mercedes dealers.). towball: 329059600001 Step DC-IR A906 520 0531 is not utilisable. Utilisable step: 313285600001 or 313440600001	04/06-		313 376 600 001			120	20.0	18.1	150	3500		313 105 300 107	-12/14 for vehicles without preparation	S	CAN	C	E	--	--	V	90	B	
												313 105 300 113	-12/14 for vehicles without preparation	S	CAN	C	E	D1	--	V	90	B	
												313 107 300 107	01/15- for vehicles without preparation	S									
												313 107 300 113	01/15- for vehicles without preparation	S									
												313 108 300 113	01/15- for vehicles with preparation	S									
												321 106 300 113	-12/14 vehicles with preparation	S	CAN	C	E	D	--	H	45	B	

Mercedes-Benz

















Mercedes Sprinter Van types 209-224 and 309-324 Vehicles with 3,0 and 3,5 t max. total weight, increase to 3,8 t max. total weight is possible For vehicles with integrated step device in the bumper the middle part of the outer bumper must be exchanged (Please order separately at Mercedes dealers.). towball: 329059600001 Step DC-IR A906 520 0531 is not utilisable. Utilisable step: 313285600001 or 313440600001	04/06-12/14	KIT		313 376 900 113			120	22.0	18.1	150	3500		included in the KIT		-12/14 for vehicles without preparation	S	CAN	C	E	D1	--	V	90	B
Mercedes Sprinter Chassis Cab types 411-424 and 509-524 Vehicles with 5,0 t max. total weight, reduction to 4,6 t max. total weight is possible wheelbase: 3665 + 4325 mm towball: 329059600001	04/06-			313 275 600 001			90	18.0	20.2	150	3500		313 105 300 107		-12/14 for vehicles without preparation	S	CAN	C	E	--	--	V	90	B
													313 105 300 113		-12/14 for vehicles without preparation	S	CAN	C	E	D1	--	V	90	B
													313 107 300 107		01/15- for vehicles without preparation	S								
													313 107 300 113		01/15- for vehicles without preparation	S								
													313 108 300 113		01/15- for vehicles with preparation	S								
													321 106 300 113		-12/14 vehicles with preparation	S	CAN	C	E	D	--	H	45	B

Mercedes Sprinter Chassis Cab types 209-224 and 309-324 Vehicles with 3,0 and 3,5 t max. total weight, increase to 3,8 t max. total weight is possible exc. vehicles with underrun guard towball: 329059600001	04/06-		313 377 600 001			90	20.0	18.1	150	3500		313 105 300 107	-12/14 for vehicles without preparation	S	CAN	C	E	--	--	V	90	B		
						313 105 300 113	-12/14 for vehicles without preparation	S	CAN	C		E	D1	--	V	90	B							
						313 107 300 107	01/15- for vehicles without preparation	S																
						313 107 300 113	01/15- for vehicles without preparation	S																
						313 108 300 113	01/15- for vehicles with preparation	S																
						321 106 300 113	-12/14 vehicles with preparation	S	CAN	C		E	D	--	H	45	B							
Mercedes Sprinter Chassis Cab types 411-424 and 509-524 Vehicles with 5,0 t max. total weight, reduction to 4,6 t max. total weight is possible wheelbase: 3665 + 4325 mm towball: 329059600001	04/06-12/14	KIT		313 275 900 113		90	20.0	20.2	150	3500		included in the KIT	-12/14 for vehicles without preparation	S	CAN	C	E	D1	--	V	90	B		
Mercedes Sprinter Chassis Cab types 209-224 and 309-324 Vehicles with 3,0 and 3,5 t max. total weight, increase to 3,8 t max. total weight is possible exc. vehicles with underrun guard towball: 329059600001	04/06-12/14	KIT		313 377 900 113		90	22.0	18.1	150	3500		included in the KIT	-12/14 for vehicles without preparation	S	CAN	C	E	D1	--	V	90	B		
Mercedes V-Klasse	04/14-			313 435 600 001		90	20.0	13.8	100	2500		313 436 300 107											B	
				313 436 600 001		90	21.0	13.8	100	2500		313 436 300 113												B
		KIT		313 435 900 113		90	22.0	13.8	100	2500		included in the KIT												B
		KIT		313 436 900 113		90	23.0	13.8	100	2500														

Mercedes-Benz



















Mercedes Vaneo exc. vehicles with dual fuel engine and automatic transmission -10/02 (- chassis-no. 414.700 1N219 022)	02/02-05		313 188 600 001			120	15.0	7.4	75	1200		313 174 300 107	→							S	FRE	--	E	--	--	H	60	L													
																																S	FRE	--	E	D1	L1	H	60	L	
Mercedes Vario Van 613D, 616D, 618D, 813D/DA, 816D/DA, 817, 818 D/DA for vans without coupling bolt inc. 508D inc. towball 329062600001	01/06-		313 270 600 001	→		90	16.0	23.5	140	3500																															
Mercedes Vario Van 613D, 616D, 618D, 813D/DA, 816D/DA, 817, 818 D/DA for vehicles with coupling bolt system, inc. 508D towing bracket inc. towball 329059600001	01/06-		313 271 600 001	→		90	16.0	23.5	140	3500																															
Mercedes Vario Van/Chassis Cab 613D, 616D, 618D, 813D/DA, 816D/DA, 817, 818 D/DA + flatbed + dump truck towing bracket inc. towball 329062600001	01/06-		313 270 600 001	→		90	16.0	23.5	140	3500																															
Mercedes Vito	09/14-		313 435 600 001			90	20.0	13.8	100	2500		313 436 300 107																			B										
		KIT		313 435 900 113			90	22.0	13.8	100	2500		included in the KIT																				B								
							KIT		313 436 900 113																								90	23.0	13.8	100	2500				
Mercedes Vito / Viano / V Class exc. vehicles with park distance control	03/96-08/03		313 089 600 001			150	17.0	11.9	75	2200		313 101 300 107																			S	C2	--	E1	--	--	V	90	L		
Mercedes Vito / Viano / V Class inc. vehicles from 02/04, 4x4	09/03-		313 175 600 001			120	18.0	12.1	100	2000		313 176 300 107																				S	FRE	--	E1	--	--	V	75	L	





















Mercedes Vito / Viano / V Class from chassis no. 16793 inc. 4x4 Vito -08/14	02/04-04/14			313 240 600 001		120	19.0	13.8	150	2500		313 176 300 107			S	FRE	--	E1	--	--	V	75	L
												313 176 300 113			S	FRE	--	E1	D1	L1	V	75	L
		KIT		313 240 900 113		120	20.5	13.8	150	2500		included in the KIT			S	FRE	--	E1	D1	L1	V	75	L
Mercedes Vito / Viano / V Class from chassis no. 16793 inc. 4x4, exc. Brabus Please order separately cover for bumper cutout at Mercedes dealer's. Vito -08/14	02/04-04/14			313 382 600 001		90	20.0	13.5	150	2500		313 176 300 107			S	FRE	--	E1	--	--	V	75	L
												313 176 300 113			S	FRE	--	E1	D1	L1	V	75	L
		KIT		313 382 900 113		90	22.0	13.5	150	2500		included in the KIT			S	FRE	--	E1	D1	L1	V	75	L

Mitsubishi Colt 5 doors	06/04-		340 074 600 001		90	20.0	6.4	50	1000	300 072 300 107			--	FRE	--	--	--	--	V	B											
																			--	FRE	--	--	D1	L1	V	B					
Mitsubishi Colt 3 doors, CZ3	06/05-		340 068 600 001		90	19.0	5.0	50	750	300 072 300 107			--	FRE	--	--	--	--	V	B											
																		--	FRE	--	--	D1	L1	V	B						
Mitsubishi Crossover ASX	06/10-		340 092 600 001		90	22.0	8.5	70	1400	340 093 300 113			S	A	--	--	D	L	H	60	B										
																		S	--	--	E1	--	--	H	45	L					
		KIT		340 092 900 113		90	24.0	8.5	70	1400	included in the KIT			S	A	--	--	D	L	H	60	B									
						KIT		340 093 900 113		90													26.0	8.5	70	1400					
Mitsubishi Grandis	04-11		340 080 600 001	→	90	22.0	10.8	132	2000	300 210 300 113															--	A	--	E1	D1	L1	V
Mitsubishi L200 pick-up, 4 WD, towball inc. exc. 2 WD	09/96-01/06		340 087 600 001			28.0	14.7	80	3000	300 061 300 107			--	C2	--	E1	--	--	V	B											
																		--	C2	--	--	--	--	V	B						
Mitsubishi L200 Club-Cab, Single-Cab Double-Cab -07/09 exc. Double-Cab 08/09-	01/06-		340 089 600 001		90	35.0	14.7	120	3000	300 052 300 107			--	FRE	--	E1	--	--	V	B											
																	--	FRE	--	E1	D1	--	--	V	B						
Mitsubishi L200 Double-Cab incl. Longbed	08/09-		340 091 600 001		60	35.0	14.7	120	3000	300 052 300 107			--	FRE	--	E1	--	--	V	B											
																	--	FRE	--	E1	D1	--	--	V	B						
Mitsubishi Lancer Saloon inc. Sportback exc. Ralliart	12/07-		340 096 600 001		60	21.0	8.4	75	1400	300 210 300 107			--	A	--	--	--	--	V	B											
																		--	A	--	E1	D1	L1	V	90	B					
Mitsubishi Outlander	05/03-04/07		340 090 600 001			25.0	9.1	80	1600	300 072 300 107			--	FRE	--	--	--	--	V	B											
																		--	FRE	--	--	D1	L1	V	B						













Mitsubishi



















Mitsubishi

Mitsubishi Outlander	04/07-09/12			340 094 600 001		90	27.0	10.9	100	2000		340 075 300 113			S	FRE	--	E	D	L	H	75	B
		KIT		340 094 900 113		90	29.0	10.9	100	2000		included in the KIT			S	FRE	--	E	D	L	H	75	B
Mitsubishi Outlander inc. PHEV Hybrid	09/12-			340 098 600 001		90	25.0	11.0	100	2000		340 099 300 113	PHEV = 300210300113		S	A	--	E2	D	L	V	75	B
				340 099 600 001		90	25.0	11.0	100	2000													
Mitsubishi Outlander exc. PHEV Hybrid	09/12-	KIT		340 098 900 113		90	27.0	11.0	100	2000		included in the KIT	exc. PHEV		--	A	--	E1	D1	L1	V	90	B
		KIT		340 099 900 113		90	27.0	11.0	100	2000													
Mitsubishi Shogun	03/07-			340 071 600 001		120	18.0	15.9	132	3180		340 072 300 113			S	FRE	--	--	D1	L1	V	60	L
				340 072 600 001		120	19.0	15.9	132	3180													
Mitsubishi Shogun Pinin	99-			340 056 600 001			20.2	8.0	75	1500		300 072 300 107			--	FRE	--	--	--	--	V		B
												300 072 300 113			--	FRE	--	--	D1	L1	V		B
Mitsubishi Space Star	98-05			340 054 600 001	 		14.1	7.7	75	1400		300 072 300 107			--	FRE	--	--	--	--	V		B
												300 072 300 113			--	FRE	--	--	D1	L1	V		B

Nissan Almera 3 and 5 doors, Hatchback N16	03/00-		332 168 600 001			60	13.7	8.0	75	1560	300 072 300 107 300 072 300 113			--	FRE	--	--	--	--	V	B	
																		--	FRE	--	--	D1
Nissan Almera 4 doors, Saloon N16	07/00-		332 286 600 001			60	20.0	8.1	75	1500	300 072 300 107 300 072 300 113			--	FRE	--	--	--	--	V	B	
																	--	FRE	--	--	D1	L1
Nissan Almera Tino	08/00-		332 162 600 001			>150	17.0	8.4	75	1650	300 072 300 107 300 072 300 113			--	FRE	--	--	--	--	V	B	
																	--	FRE	--	--	D1	L1
Nissan Cabstar Chassis Cab type 406 inc. towball 329059600001	10/06-		332 273 600 001			60	22.5	19.4	150	3500	300 201 300 113			--	A	--	E1	D1	--	V	B	
Nissan Interstar Van	01/98-		316 124 600 001			60	28.5	13.7	85	2300	300 052 300 107	-11/03	--	FRE	--	E1	--	--	--	V	B	
											300 052 300 113	-11/03	--	FRE	--	E1	D1	--	V	B		
											316 130 300 113	11/03-	S	FRE	--	--	D1	L1	H	45	L	
Nissan Interstar Van inc. towball 329057600001 When mounting the swap system please order towball order no. 329059600001. exc. Master Maxi	01/98-		316 126 600 001			60	29.8	15.3	80	2800	300 052 300 107	-11/03	--	FRE	--	E1	--	--	--	V	B	
											300 052 300 113	-11/03	--	FRE	--	E1	D1	--	V	B		
											316 130 300 113	11/03-	S	FRE	--	--	D1	L1	H	45	L	
Nissan Interstar Chassis Cab inc. towball 329057600001 When mounting the swap system please order towball order no. 329059600001.	01/98-		316 126 600 001			60	29.8	15.3	80	2800	300 052 300 107	-10/03	--	FRE	--	E1	--	--	--	V	B	
											300 052 300 113	-10/03	--	FRE	--	E1	D1	--	V	B		
											316 135 300 113	11/03-	S	A	--	E1	D1	--	H	45	L	
Nissan Juke 2 WD exc. Nismo	10/10-		332 304 600 001			60	25.0	8.5	75	1500	332 305 300 113			S	A	--	E1	D1	L1	V	60	B
						KIT		332 304 900 113		60	27.0	8.5	75	1500	included in the KIT			S	A	--	E1	D1
Nissan Juke 4 WD exc. Nismo	10/10-		332 305 600 001			60	27.0	8.5	75	1500	332 305 300 113			S	A	--	E1	D1	L1	V	60	B
						KIT		332 305 900 113		60	29.0	8.5	75	1500	included in the KIT			S	A	--	E1	D1
Nissan Kubistar	02-		316 201 600 001			60	12.0	7.6	75	1320	316 205 300 107			S	A	--	--	D1	--	H	45	B
											316 205 300 113			S	A	--	--	D1	--	H	45	B



















Nissan























Nissan Kubistar 4x4	02-		316 205 600 001			60	12.0	7.6	75	1320		316 205 300 107			S	A	--	--	D1	--	H	45	B						
																				S	A	--	--	D1	--	H	45	B	
Nissan Micra K12	03-10		332 295 600 001			90	20.0	6.0	50	1000		300 060 300 107			--	C2	--	E1	--	--	H	45	B						
																				--	C2	--	E1	D1	L1	H	45	B	
Nissan NV 200 / Evalia	10/09-		332 264 600 001			120	18.0	7.5	75	1100		332 265 300 107			S	FRE	--	--	--	--	V	60	L						
																				S	FRE	--	--	D1	L1	V	60	B	
		KIT		332 264 900 113			120	20.0	7.5	75	1100		included in the KIT			S	FRE	--	--	D1	L1	V	60	B					
Nissan NV 400 box/estate front wheel drive	03/10-		316 318 600 001			60	19.3	14.3	100	2500		316 300 300 107	for vehicles without central plug connection			S	FRE	--	E1	--	--	H	45	B					
																					S	FRE	--	E1	D1	L1	H	45	B
																						S	FRE	--	E2	D1	L1	H	15
Nissan NV 400 box/estate rear wheel drive	03/10-		316 327 600 001			60	19.7	14.3	100	2500		316 300 300 107	for vehicles without central plug connection			S	FRE	--	E1	--	--	H	45	B					
																					S	FRE	--	E1	D1	L1	H	45	B
																						S	FRE	--	E2	D1	L1	H	15

Nissan NV 400 box/estate rear wheel drive with twin wheels	03/10-		316 328 600 001			60	19.7	15.8	100	3000		316 300 300 107	for vehicles without central plug connection	S	FRE	--	E1	--	--	H	45	B	
			316 300 300 113			for vehicles without central plug connection	S	FRE	--	E1		D1	L1	H	45	B							
			316 318 300 113			for vehicles with central plug connection	S	FRE	--	E2		D1	L1	H	15	B							
Nissan NV 400 platform front + rear wheel drive	07/10-		316 319 600 001			60	16.0	14.3	100	2500		300 201 300 113		--	A	--	E1	D1	--	V		B	
			316 319 300 113				S	FRE	--	E1		D1	--	H	15	B							
Nissan NV 400 platform rear wheel drive with twin wheels	07/10-		316 329 600 001			60	15.0	15.8	100	3000		300 201 300 113		--	A	--	E1	D1	--	V		B	
			316 319 300 113				S	FRE	--	E1		D1	--	H	15	B							
Nissan Note	03/06-10/13		332 239 600 001			70	90	16.5	6.9	50	1200		300 072 300 107		--	FRE	--	--	--	V		B	
			332 241 600 001			70	90	17.5	6.9	50	1200		300 072 300 113		--	FRE	--	--	D1	L1	V		B
Nissan Note	10/13-		332 308 600 001			70	90	15.0	3.5	45	450		300 210 300 107		--	A	--	--	--	V		B	
			300 210 300 113				--	A	--	E1	D1		L1	V	90	B							
Nissan Pathfinder	03/05-		332 301 600 001			70	60	15.0	16.4	140	3500		332 303 300 113		S	FRE	--	E2	D1	L1	V	75	B
			332 302 600 001			70	60	15.0	16.4	140	3500												
			332 303 600 001			70	60	16.0	16.4	140	3500												
		KIT		332 301 900 113			70	60	17.0	16.4	140	3500		included in the KIT	S	FRE	--	E2	D1	L1	V	75	B
		KIT		332 303 900 113			70	>150	18.0	16.4	140	3500											
Nissan Pick-up MD22 Navarra SingleCab, KingCab and DoubleCab 4x4 for vehicles with chrome bumper and integrated step	03/00-07/05		332 207 600 001				150	33.0	15.0	120	3000		300 061 300 107		--	C2	--	E1	--	--	V		B
			300 061 300 113				--	C2	--	--	--		V		B								















Nissan

































Nissan





















Nissan Pick-up NP300 SingleCab, KingCab and DoubleCab 4x4 for vehicles with chrome bumper and integrated step	03/00-		332 207 600 001			150	33.0	15.0	120	3000		300 061 300 107			--	C2	--	E1	--	--	V		B		
												300 061 300 113			--	C2	--	--	--	V		B			
Nissan Pick-up D40 Navarra for vehicles with bumper with integrated step inc. towball 329076600001 if using a swap system (bolt coupling or 4-whole-towball) an additional plate is necessary, order no. 932245605002	07/05-		332 321 600 001			60	25.0	15.5	120	3000		300 052 300 107			--	FRE	--	E1	--	--	V		B		
												300 052 300 113			--	FRE	--	E1	D1	--	V		B		
Nissan Pixo	09-		332 306 600 001			90	15.0	4.2	50	650		332 306 300 113			S	FRE	--	--	D1	--	H	60	L		
												KIT				332 306 900 113		90	17.0	4.2	50	650	included in the KIT	S	FRE
Nissan Primastar	03-09/14		314 364 600 001			60	21.0	12.3	85	2100		314 364 300 113			S									B	
												314 860 300 107				08/06-03/10	S	FRE	--	--	--	--	H	60	B
												314 860 300 113				08/06-03/10	S	FRE	--	--	D1	L1	H	60	B
												314 870 300 107				03/10-	S	FRE	--	--	--	--	H	60	B
												314 870 300 113				03/10-	S	FRE	--	--	D1	L1	H	60	B
Nissan Primastar	08/06-03/10	KIT		314 364 900 113		60	23.0	12.3	85	2100	included in the KIT			08/06-03/10	S	FRE	--	--	D1	L1	H	60	B		
Nissan Primastar	03/10-09/14	KIT		314 870 900 113		60	23.0	12.3	85	2100	included in the KIT			03/10-	S	FRE	--	--	D1	L1	H	60	B		
Nissan Primera Estate WP11/W11 Traveller	98-03/02		332 133 600 001			>150	25.5	8.8	75	1700		300 061 300 107			--	C2	--	E1	--	--	V		B		
												300 061 300 113			--	C2	--	--	--	V		B			
												300 072 300 107			--	FRE	--	--	--	V		B			
												300 072 300 113			--	FRE	--	--	D1	L1	V		B		
Nissan Primera Estate WP12	03/02-		332 205 600 001			120	17.0	9.6	75	1800		300 072 300 107			--	FRE	--	--	--	V		B			
												300 072 300 113			--	FRE	--	--	D1	L1	V		B		

Nissan Primera Hatchback/ Saloon P12 hatchback	03/02-		332 197 600 001			150	17.0	9.6	75	1800		300 072 300 107			--	FRE	--	--	--	--	V		B		
															300 072 300 113			--	FRE	--	--	D1	L1	V	
Nissan Pulsar	09/14-		332 329 600 001									332 314 300 107			S	A	--	--	--	--	V	90	B		
				332 330 600 001									332 314 300 113			S	A	--	--	D1	L1	V	90	B	
		KIT		332 329 900 113									included in the KIT			S	A	--	--	D1	L1	V	90	B	
		KIT		332 330 900 113													S	A	--	--	D1	L1	V	90	B
Nissan Qashqai	02/14-	KIT		332 326 900 113				9.4	100	1800		included in the KIT			S	A	--	E2	D	L1	H	60	B		
		KIT		332 327 900 113				9.4	100	1800				02/14-			S	A	--	E2	D	L1	H	60	B
Nissan Qashqai, Qashqai +2	02/07-		332 319 600 001			120	22.0	9.4	100	1800		332 262 300 107		-01/14	S	A	--	--	--	--	V	75	B		
												332 262 300 113		-01/14	S	A	--	--	D1	L1	V	75	B		
				332 266 600 001			120	22.6	8.6	70	1400		332 327 300 107		02/14-	S	A	--	E2	--	--	H	60	B	
				332 247 600 001				120	25.0	9.4	100	1800		332 327 300 113		02/14-	S	A	--	E2	D	L1	H	60	B
				332 327 600 001				25.0	9.4	100	1800							S	A	--	E2	D	L1	H	60
Nissan Qashqai, Qashqai +2	02/07-01/14	KIT		332 246 900 113			120	24.0	9.4	100	1800	included in the KIT			S	A	--	--	D1	L1	V	75	B		
		KIT		332 247 900 113			120	27.0	9.4	100	1800				-01/14	S	A	--	--	D1	L1	V	75	B	

























Nissan



























Nissan Qashqai, Qashqai +2	02/14-	KIT		332 326 900 113				9.4	100	1800		included in the KIT	02/14-	S	A	--	E2	D	L1	H	60	B	
		KIT		332 327 900 113				9.4	100	1800													
Nissan X-Trail	09/01-06/07			332 237 600 001		150	17.4	11.8	100	2500		300 061 300 107		--	C2	--	E1	--	--	V		B	
				332 223 600 001			150	21.0	11.1	100	2250		300 061 300 113		--	C2	--	--	--	V		B	
Nissan X-Trail	06/07-			332 261 600 001		90	26.0	10.8	100	2200		332 262 300 107		S	A	--	--	--	--	V	75	B	
				332 263 600 001		90	27.0	10.8	100	2200		332 262 300 113		S	A	--	--	D1	L1	V	75	B	
				332 262 600 001		90	27.5	10.8	100	2200													
		KIT		332 261 900 113		90	28.0	10.8	100	2200		included in the KIT		S	A	--	--	D1	L1	V	75	B	
		KIT		332 262 900 113		90	29.5	10.8	100	2200													
Nissan X-Trail	07/14-			332 323 600 001		90	27.0	10.9	80	2000		332 327 300 107		S	A	--	E2	--	--	H	60	B	
												332 327 300 113		S	A	--	E2	D	L1	H	60	B	

Opel Agila 5 doors	03-04/08		314 332 600 001	→		120	20.0	5.3	50	900	300 072 300 107										--	FRE	--	--	--	--	V		B															
																																			--	FRE	--	--	D1	L1	V		B	
Opel Agila	03-04/08		314 347 600 001			120	20.0	6.0	80	1000	300 072 300 107										--	FRE	--	--	--	--	V		B															
																																			--	FRE	--	--	D1	L1	V		B	
Opel Agila only for 1,2 l gas engine	04/08-		314 308 600 001			90	16.0	4.2	50	600	332 306 300 113										S	FRE	--	--	D1	--	H	60	L															
							314 309 600 001			90											16.0	4.2	50	600																				
		KIT		314 308 900 113			90	18.0	4.2	50	600	included in the KIT										S	FRE	--	--	D1	--	H	60	L														
		KIT		314 309 900 113			90	18.0	4.2	50	600																																	
Opel Antara exc. vehicles with bike carrier system Flex-Fix exc. vehicles with height control	02/07-		314 304 600 001	→		150	24.0	12.3	150	2500	314 422 300 113											S	A	--	E2	D	L1	V	90	L														
							314 305 600 001			150												24.0	12.3	150	2500	342 027 300 113										S	FRE	--	E1	D	L1		30	B
							314 486 600 001			150												24.0	12.3	150	2500	349 025 300 113											S	A	--	E	D1	L1	V	90
Opel Antara exc. vehicles with bike carrier system Flex-Fix exc. vehicles with height control	02/07-05/11	KIT		314 304 900 113							included in the KIT										S	A	--	E	D1	L1	V	90	B															
		KIT		314 305 900 113																																								
Opel Antara exc. vehicles with bike carrier system Flex-Fix exc. vehicles with height control	05/11-	KIT		314 421 900 113							included in the KIT											S	A	--	E2	D	L1	V	90	L														
		KIT		314 422 900 113																																								
Opel Astra Convertible - Twin Top	05/06-		314 310 600 001			100	20.0	8.0	75	1400	314 300 300 107										S	FRE	C	E	--	--	H	45	B															
																																			S	FRE	C	E	D	L1	H	45	B	





















Opel Astra H Hatchback inc. GTC exc. VXR / 240 HP	03/04-		314 299 600 001		60	21.5	9.0	75	1650		300 210 300 113	for vehicles without rear central electronic (REC)	--	A	--	E1	D1	L1	V	90	B	
			314 281 600 001		60	21.5	9.0	75	1650		314 300 300 107	for vehicles with rear central electronic (REC)	S	FRE	C	E	--	--	H	45	B	
											314 300 300 113	for vehicles with rear central electronic (REC)	S	FRE	C	E	D	L1	H	45	B	
	KIT		314 299 900 113		60	23.5	9.0	75	1650		included in the KIT	for vehicles with rear central electronic (REC)	S	FRE	C	E	D	L1	H	45	B	
	KIT		314 281 900 113		60	23.5	9.0	75	1650													
	Opel Astra J 4 doors Saloon	10/12-		314 412 600 001		60	22.5	9.6	75	1500		314 386 300 107		S	CAN	--	E	--	--	V	90	B
			314 414 600 001		60	21.0	9.6	75	1500		314 386 300 113		S	CAN	--	E	D	L1	V	90	B	
KIT				314 412 900 113		60	24.5	9.6	75	1500		included in the KIT		S	CAN	--	E	D	L1	V	90	B
KIT				314 414 900 113		60	23.0	9.6	75	1500												
Opel Astra J Hatchback exc. vehicles with bike carrier system Flex-Fix	12/09-		314 474 600 001		60	23.0	9.6	75	1800		314 386 300 107		S	CAN	--	E	--	--	V	90	B	
			314 473 600 001		60	23.0	9.6	75	1800		314 386 300 113		S	CAN	--	E	D	L1	V	90	B	
		KIT		314 474 900 113		60	25.0	9.6	75	1800		included in the KIT		S	CAN	--	E	D	L1	V	90	B
		KIT		314 473 900 113		60	25.0	9.6	75	1800												























Opel

Opel Astra J GTC	01/12-			314 441 600 001		60	22.0	9.6	75	1800		314 386 300 107			S	CAN	--	E	--	--	V	90	B
				314 440 600 001		60	22.0	9.6	75	1800		314 386 300 113			S	CAN	--	E	D	L1	V	90	B
		KIT		314 441 900 113		60	24.0	9.6	75	1800		included in the KIT			S	CAN	--	E	D	L1	V	90	B
		KIT		314 440 900 113		60	24.0	9.6	75	1800						S	CAN	--	E	D	L1	V	90
Opel Astra J Sports Tourer exc. vehicles with bike carrier system Flex-Fix Please order separately cover for bumper cutout at Vauxhall dealers.	11/10-			314 406 600 001		60	25.0	9.6	75	1800		314 386 300 107			S	CAN	--	E	--	--	V	90	B
				314 406 900 113		60	27.0	9.6	75	1800		314 386 300 113			S	CAN	--	E	D	L1	V	90	B
Opel Astra J Sports Tourer exc. vehicles with bike carrier system Flex-Fix	11/10-			314 407 600 001		60	24.5	9.6	75	1800		314 386 300 107			S	CAN	--	E	--	--	V	90	B
				314 407 900 113		60	26.5	9.6	75	1800		314 386 300 113			S	CAN	--	E	D	L1	V	90	B
Opel Cascada Convertible	05/13-			314 472 600 001		60		9.6	75	1300		314 386 300 113			S	CAN	--	E	D	L1	V	90	B
Opel Combo	02/12-			306 368 600 001		60	23.0	9.2	100	1500		306 605 300 107			S	FRE	--	E	--	--	V	90	B
				306 370 600 001		60	25.0	9.2	100	1500		306 605 300 113			S	FRE	--	E	D1	L1	V	90	B
				306 369 600 001		60	25.0	9.2	100	1500						S	FRE	--	E	D1	L1	V	90
		KIT		306 368 900 113		60	25.0	9.2	100	1500		included in the KIT			S	FRE	--	E	D1	L1	V	90	B
KIT		306 369 900 113		60	27.0	9.2	100	1500						S	FRE	--	E	D1	L1	V	90	B	











Opel Combo for vehicles with gas drive (CNG)	02/12-			306 382 600 001		60	25.0	7.0	75	1000		306 605 300 107			S	FRE	--	E	--	--	V	90	B
				306 381 600 001		60	25.0	7.0	75	1000		306 605 300 113			S	FRE	--	E	D1	L1	V	90	B
	KIT		306 382 900 113		60	27.0	7.0	75	1000		included in the KIT			S	FRE	--	E	D1	L1	V	90	B	
	KIT		306 381 900 113		60	27.0	7.0	75	1000						S	FRE	--	E	D1	L1	V	90	B
Opel Corsa	93-09/00			314 231 600 001	→ 	>150	13.7	5.9	50	1000		300 060 300 113			--	C2	--	E1	D1	L1	H	45	B
Opel Corsa inc. Corsa Van	10/00-10/06			314 267 600 001	→ 	150	23.0	7.1	50	1200		300 072 300 107			--	FRE	--	--	--	--	V		B
												300 072 300 113			--	FRE	--	--	D1	L1	V		B
Opel Corsa Combo Van exc. vehicles with gas drive (CNG)	03/02-12			314 282 600 001		150	16.4	7.5	75	1200		300 072 300 107			--	FRE	--	--	--	--	V		B
		KIT		314 282 900 113		150	18.0	7.5	75	1200		314 335 300 113			S	FRE	--	E1	D1	--	H	45	L
Opel Corsa D exc. vehicles with bike carrier system Flex-Fix exc. VXR / 192 HP, exc. Gsi	10/06-12/14			314 306 600 001		60	17.0	7.7	55	1200		314 307 300 107			S	A	--	--	--	--	V	90	B
				314 307 600 001	→ 	60	18.5	7.7	55	1200		314 307 300 113			S	A	--	--	D1	--	V	90	B
				314 436 600 001		60	18.5	7.7	55	1200						S	A	--	--	D1	--	V	90
		KIT		314 306 900 113		60	19.0	7.7	55	1200		included in the KIT			S	A	--	--	D1	--	V	90	B
		KIT		314 307 900 113		60	20.5	7.7	55	1200						S	A	--	--	D1	--	V	90











Opel

Opel Corsa E exc. vehicles with bike carrier system Flex-Fix exc. VXR / 192 HP, exc. Gsi	01/15-			314 306 600 001		60	17.0	7.7	55	1200		314 436 300 107			S	CAN	--	E	--	--	V	90	B
				314 436 600 001		60	18.5	7.7	55	1200		314 436 300 113			S	CAN	--	E	D	L1	V	90	B
		KIT		314 435 900 113		60	19.0	7.7	55	1200		included in the KIT			S	CAN	--	E	D	L1	V	90	B
		KIT		314 436 900 113		60	20.5	7.7	55	1200						S	CAN	--	E	D	L1	V	90
Opel Insignia Saloon exc. VXR, inc. 4x4	11/08-			314 389 600 001		90	23.0	11.3	85	2100		314 386 300 107			S	CAN	--	E	--	--	V	90	B
				314 341 600 001		90	24.0	11.3	85	2100		314 386 300 113			S	CAN	--	E	D	L1	V	90	B
		KIT		314 389 900 113		90	25.0	11.3	85	2100		included in the KIT			S	CAN	--	E	D	L1	V	90	B
		KIT		314 341 900 113		90	25.5	11.6	85	2100						S	CAN	--	E	D	L1	V	90
Opel Insignia Sports Tourer 2 WD, front wheel drive exc. VXR	03/09-			314 390 600 001		90	23.0	11.3	85	2100		314 342 300 107	08/09-	S	CAN	--	E2	--	--	H	45	B	
				314 342 600 001		90	26.5	11.3	85	2100		314 342 300 113	08/09-	S	CAN	--	E2	D1	L1	H	45	B	
												314 402 300 113	-08/09Opel control units with code letter AE (from chassis no. GM87C891067386) have to be replaced by control units with trailer specification, Opel no. 12 379 96.	S	CAN	C	E	D1	L1	H	60	B	















Opel Insignia Sports Tourer 4 WD exc. VXR inc. Country Tourer (01/14-)	03/09-		314 408 600 001		90	25.0	11.3	85	2100	314 342 300 107 314 342 300 113 314 402 300 113	08/09- 08/09- -08/09Opel control units with code letter AE (from chassis no. GM87C891067386) have to be replaced by control units with trailer specification, Opel no. 12 379 96.	S	CAN	--	E2	--	--	H	45	B									
			314 409 600 001		90	29.0	11.3	85	2100												S	CAN	--	E2	D1	L1	H	45	B
Opel Insignia Sports Tourer 2 WD, front wheel drive exc. VXR	08/09-	KIT 	314 390 900 113		90	23.0	11.3	85	2100	included in the KIT	08/09-	S	CAN	--	E2	D1	L1	H	45	B									
			KIT 	314 342 900 113		90	28.0	11.3	85												2100								
Opel Meriva exc. VXR thermal-insulation plate is necessary	05/03-		314 289 600 001		60	23.0	8.3	60	1300	314 289 300 113		S	FRE	--	E1	D1	--	H	60	B									
			KIT 	314 289 900 113		60	24.0	8.3	60												1300	included in the KIT			S	FRE	--	E1	D1
Opel Meriva exc. vehicles with bike carrier system Flex-Fix Please check if there is a towing capacity in the car documents.	06/10-		314 394 600 001		60	19.0	8.3	75	1300	314 386 300 107 314 386 300 113		S	CAN	--	E	--	--	V	90	B									
				314 392 600 001		60	20.0	8.3	75												1300	S	CAN	--	E	D	L1	V	90
		KIT 	314 394 900 113		60	21.0	8.3	75	1300	included in the KIT		S	CAN	--	E	D	L1	V	90	B									
			KIT 	314 392 900 113		60	22.0	8.3	75												1300								
Opel Mokka exc. vehicles with bike carrier system Flex-Fix	10/12-		314 450 600 001	→ 	60	21.0	7.5	75	1200	314 451 300 107 314 451 300 113		S	A	--	E2	--	--	V	90	B									
				314 451 600 001	→ 	60	23.0	7.5	75												1200	S	A	--	E2	D	L1	V	90























Opel

Opel Mokka exc. vehicles with bike carrier system Flex-Fix exc. vehicles with height control	10/12-		314 511 600 001		60	21.0	8.6	75	1400		314 451 300 107			S	A	--	E2	--	--	V	90	B	
			314 510 600 001		60	23.0	8.6	75	1400		314 451 300 113			S	A	--	E2	D	L1	V	90	B	
		KIT		314 450 900 113		60	23.0	8.6	75	1400		included in the KIT			S	A	--	E2	D	L1	V	90	B
			KIT		314 451 900 113		60	25.0	8.6	75	1400					S	A	--	E2	D	L1	V	90
Opel Movano Van	01/98-		316 124 600 001		60	28.5	13.7	85	2300		300 052 300 107	-11/03	--	FRE	--	E1	--	--	V		B		
											300 052 300 113	-11/03	--	FRE	--	E1	D1	--	V	B			
											316 130 300 113	11/03-	S	FRE	--	--	D1	L1	H	45	L		
Opel Movano Van Towing bracket inc. towball no. 329057600001 Assembly of automatic bolt coupling or swap system is possible, when using the swap system please order the towball no. 329059600001.	01/98-		316 126 600 001		60	29.8	15.3	80	2800		300 052 300 107	-11/03	--	FRE	--	E1	--	--	V		B		
											300 052 300 113	-11/03	--	FRE	--	E1	D1	--	V	B			
											316 130 300 113	11/03-	S	FRE	--	--	D1	L1	H	45	L		
Opel Movano Van front wheel drive	03/10-		316 318 600 001		60	19.3	14.3	100	2500		316 300 300 107	for vehicles without central plug connection	S	FRE	--	E1	--	--	H	45	B		
											316 300 300 113		for vehicles without central plug connection	S	FRE	--	E1	D1	L1	H	45	B	
											316 318 300 113		for vehicles with central plug connection	S	FRE	--	E2	D1	L1	H	15	B	
Opel Movano Van rear wheel drive	03/10-		316 327 600 001		60	19.7	14.3	100	2500		316 300 300 107	for vehicles without central plug connection	S	FRE	--	E1	--	--	H	45	B		
											316 300 300 113		for vehicles without central plug connection	S	FRE	--	E1	D1	L1	H	45	B	
											316 318 300 113		for vehicles with central plug connection	S	FRE	--	E2	D1	L1	H	15	B	





Opel Movano Van rear wheel drive with twin wheels	03/10-		316 328 600 001			60	19.7	15.8	100	3000		316 300 300 107	for vehicles without central plug connection	S	FRE	--	E1	--	--	H	45	B
												316 300 300 113	for vehicles without central plug connection	S	FRE	--	E1	D1	L1	H	45	B
												316 318 300 113	for vehicles with central plug connection	S	FRE	--	E2	D1	L1	H	15	B
Opel Movano Chassis Cab Towing bracket inc. towball no. 329057600001 Assembly of automatic bolt coupling or swap system is possible, when using the swap system please order the towball no. 329059600001.	01/98-		316 126 600 001			60	29.8	15.3	80	2800		300 052 300 107	-10/03	--	FRE	--	E1	--	--	V		B
												300 052 300 113	-10/03	--	FRE	--	E1	D1	--	V		B
												316 135 300 113	11/03-	S	A	--	E1	D1	--	H	45	L
Opel Movano Chassis Cab front + rear wheel drive	07/10-		316 319 600 001			60	16.0	14.3	100	2500		316 319 300 113		S	FRE	--	E1	D1	--	H	15	B
Opel Movano Chassis Cab rear wheel drive with twin wheels	07/10-		316 329 600 001			60	15.0	15.8	100	3000		316 319 300 113		S	FRE	--	E1	D1	--	H	15	B
Opel Omega B Estate exc. vehicles with height control	03/94-		314 205 600 001	→		150	22.5	11.0	75	2100		300 025 300 173	additional kit for checkcontrol	--	--	--	E1	--	--	V	30	B
												300 210 300 107		--	A	--	--	--	V		B	
												300 210 300 113		--	A	--	E1	D1	L1	V	90	B
Opel Omega B Saloon	03/94-		314 265 600 001	→		150	18.0	11.0	75	2100		300 210 300 107		--	A	--	--	--	V		B	
												300 210 300 113	--	A	--	E1	D1	L1	V	90	B	
Opel Signum	05/03-		314 284 600 001			120	26.0	10.7	80	2000		314 295 300 113		S	FRE	--	E	D	L1	H	30	B
			314 283 600 001			120	26.0	10.7	80	2000												
Opel Vectra B Estate	11/96-09/03		314 253 600 001	→		>150	25.8	9.3	75	1700		300 210 300 107		--	A	--	--	--	V		B	
												300 210 300 113	--	A	--	E1	D1	L1	V	90	B	
												314 265 300 113	→	S	FRE	--	E1	D1	--	V	75	L













Opel

Opel Vectra B Saloon	10/95-03/02			314 250 600 001	→ 	150	22.0	9.3	75	1700		300 210 300 107			--	A	--	--	--	--	V		B		
													300 210 300 113			--	A	--	E1	D1	L1	V	90	B	
				314 251 600 001	→	150	23.2	9.3	75	1700		314 264 300 107	→			S	FRE	--	E	--	--	--	V	75	L
														314 264 300 113	→		S	FRE	--	E	D1	--	V	75	L
Opel Vectra C Estate replaced by 314501600001	10/03-			314 295 600 001	→	60	33.5	10.7	80	2000		314 295 300 113			S	FRE	--	E	D	L1	H	30	B		
Opel Vectra C Estate	10/03-			314 297 600 001		60	33.0	10.7	80	2000															
				314 501 600 001		60	33.5	10.7	80	2000		314 295 300 113				S	FRE	--	E	D	L1	H	30	B	
Opel Vectra C Saloon inc. GTS	04/02-			314 280 600 001		150	24.0	10.5	75	2000															
				314 257 600 001		150	26.0	10.5	75	2000		314 295 300 113				S	FRE	--	E	D	L1	H	30	B	
Opel Vivaro Van	05/01-09/14			314 364 600 001		60	21.0	12.3	85	2100		314 364 300 113	-08/06	S										B	
												314 860 300 107	→	08/06-03/10	S	FRE	--	--	--	--	H	60	B		
												314 860 300 113		08/06-03/10	S	FRE	--	--	D1	L1	H	60	B		
												314 870 300 107	→	03/10-	S	FRE	--	--	--	--	H	60	B		
												314 870 300 113		03/10-	S	FRE	--	--	D1	L1	H	60	B		
Opel Vivaro Van	08/06-03/10	KIT		314 364 900 113		60	23.0	12.3	85	2100		included in the KIT	08/06-03/10	S	FRE	--	--	D1	L1	H	60	B			
Opel Vivaro Van	03/10-09/14	KIT		314 870 900 113		60	23.0	12.3	85	2100		included in the KIT	03/10-	S	FRE	--	--	D1	L1	H	60	B			















Opel Vivaro Van	09/14-			316 311 600 001		60	20.0	12.1	80	2000		316 312 300 107			S	FRE	--	E2	--	--	H	90	B	
				316 312 600 001									316 312 300 113			S	FRE	--	E2	D1	L1	H	90	B
		KIT		316 312 900 113									included in the KIT			S	FRE	--	E2	D1	L1	H	90	B
Opel Vivaro Van	10/14-	KIT		316 311 900 113		60	22.0	12.1	80	2000		included in the KIT			S	FRE	--	E2	D1	L1	H	90	B	
Opel Zafira inc. GSI with non-visible cut	04/99-07/05			314 270 600 001		150	22.8	8.9	75	1500		300 025 300 173	additional kit for checkcontrol	--	--	--	E1	--	--	V	30	B		
												314 245 300 113		S	FRE	--	E	D1	--	V	90	L		
Opel Zafira Will fit GSI with visible cut & GSR model - No info on cut for GSR	04/99-07/05			314 362 600 001		120	17.0	9.3	80	1600		300 025 300 173	additional kit for checkcontrol	--	--	--	E1	--	--	V	30	B		
		KIT		314 362 900 113		120	19.0	9.3	80	1600		314 245 300 113		S	FRE	--	E	D1	--	V	90	L		
Opel Zafira Tourer exc. CNG exc. vehicles with bike carrier system Flex-Fix To guarantee an optimal fit of the bumper it is necessary to mount a polystyrene carrier, please order from Vauxhall-dealer.	01/12-			314 438 600 001		60	27.0	9.9	75	1500		314 386 300 107		S	CAN	--	E	--	--	V	90	B		
				314 437 600 001		60	27.0	9.9	75	1500		314 386 300 113		S	CAN	--	E	D	L1	V	90	B		
		KIT		314 438 900 113		60	29.0	9.9	75	1500		included in the KIT		S	CAN	--	E	D	L1	V	90	B		
		KIT		314 437 900 113		60	29.0	9.9	75	1500				S	CAN	--	E	D	L1	V	90	B		
Opel Zafira, Zafira Family inc. facelift 01/08- exc. CNG VXR version and vehicles with sport bumper: in addition to the visible cutout a cutout is necessary. Cover for bumper cutout not available.	07/05-12			314 293 600 001		75	17.5	9.6	75	1650		314 300 300 107	for vehicles with rear central electronic (REC)	S	FRE	C	E	--	--	H	45	B		
												314 300 300 113	for vehicles with rear central electronic (REC)	S	FRE	C	E	D	L1	H	45	B		
		KIT		314 293 900 113		75	18.5	9.6	75	1650		included in the KIT		for vehicles with rear central electronic (REC)	S	FRE	C	E	D	L1	H	45	B	

















Opel

Opel Zafira, Zafira Family exc. CNG	07/05-12		314 361 600 001		90	19.0	9.6	75	1650		300 210 300 113	for vehicles without rear central electronic (REC)	--	A	--	E1	D1	L1	V	90	B
											314 300 300 107	for vehicles with rear central electronic (REC)	S	FRE	C	E	--	--	H	45	B
											314 300 300 113	for vehicles with rear central electronic (REC)	S	FRE	C	E	D	L1	H	45	B
		KIT		314 361 900 113		90	21.0	9.6	75	1650		included in the KIT	for vehicles with rear central electronic (REC)	S	FRE	C	E	D	L1	H	45























Peugeot 1007 exc. RC/120 HC with double tube exhaust system	07/05-		304 074 600 001			120	16.0	6.6	50	1100		300 210 300 107									--	A	--	--	--	--	V		B						
												300 210 300 113									--	A	--	E1	D1	L1	V	90	B						
Peugeot 1007 exc. RC/120 HC with double tube exhaust system	06-		315 143 600 001	→		120	18.5	6.5	46	1137		300 210 300 107									--	A	--	--	--	--	V		B						
												300 210 300 113									--	A	--	E1	D1	L1	V	90	B						
Peugeot 2008	06/13-		315 189 600 001			120	18.0	6.7	55	1150		315 185 300 107									S	CAN	C	E					B						
												315 185 300 113									S	CAN	C	E	D	L1		60	B						
		KIT		315 189 900 113			120	18.0	6.7	55	1150																								
																																			KIT
Peugeot 206 XS, Gti, CC, RC 99- XR/XT 04/03- 206+ 09-	99-		315 170 600 001			90	16.0	6.8	50	1200		300 072 300 107										--	FRE	--	--	--	--	V		B					
												300 072 300 113										--	FRE	--	--	D1	L1	V		B					
Peugeot 206 XR/XT	99-03/03		315 172 600 001	→		90	16.0	6.8	80	1200		300 072 300 107										--	FRE	--	--	--	--	V		B					
												300 072 300 113										--	FRE	--	--	D1	L1	V		B					
Peugeot 206 +	09-		315 171 600 001			90	17.0	6.8	50	1200		300 072 300 107										--	FRE	--	--	--	--	V		B					
												300 072 300 113										--	FRE	--	--	D1	L1	V		B					
Peugeot 206 SW	06/02-		315 176 600 001	→		90	20.0	6.6	50	1100		300 072 300 107										--	FRE	--	--	--	--	V		B					
												300 072 300 113										--	FRE	--	--	D1	L1	V		B					
Peugeot 207 inc. 207 cc convertible, inc. 207 RC - 175 HP, inc. 207 van type WG, inc. Sport	04/06-		315 113 600 001			75	16.5	6.7	60	1200		304 402 300 107										S	CAN	C1	E	--	--	V	105	B					
												304 402 300 113										S	CAN	C1	E	D	L1	V	105	B					
		KIT		315 113 900 113			75	18.5	6.7	60	1200																								



























Peugeot

Peugeot 207 SW / Estate exc. Outdoor exc. RC (double tube exhaust)	06/07-			315 118 600 001			120	17.5	6.4	46	1150		304 402 300 107			S	CAN	C1	E	--	--	V	105	B
				315 119 600 001			120	21.0	6.8	46	1150		304 402 300 113			S	CAN	C1	E	D	L1	V	105	B
		KIT		315 118 900 113			120	19.5	6.4	46	1150		included in the KIT			S	CAN	C1	E	D	L1	V	105	B
		KIT		315 119 900 113			120	23.0	6.8	46	1150						S	CAN	C1	E	D	L1	V	105
Peugeot 208	04/12-			315 184 600 001			60	12.0	7.2	53	1300		315 185 300 107			S	CAN	C	E					B
				315 185 600 001			60	12.0	7.2	53	1300		315 185 300 113			S	CAN	C	E	D	L1		60	B
		KIT		315 184 900 113			60	14.0	7.2	53	1300		included in the KIT			S	CAN	C	E	D	L1		60	B
		KIT		315 185 900 113			60	14.0	7.2	53	1300						S	CAN	C	E	D	L1		60
Peugeot 3008 exc. Hybrid	06/09-			315 157 600 001			90	22.0	9.2	70	1600		315 109 300 107			S	CAN	C	E	--	--	V	105	B
				315 159 600 001	→		90	22.0	9.2	70	1600		315 109 300 113			S	CAN	C	E	D	L1	V	105	B
				315 158 600 001			90	24.0	9.2	70	1600						S	CAN	C	E	D	L1	V	105
		KIT		315 157 900 113			90	24.0	9.2	70	1600		included in the KIT			S	CAN	C	E	D	L1	V	105	B
KIT		315 158 900 113			90	26.0	9.2	70	1600						S	CAN	C	E	D	L1	V	105	B	
Peugeot 306 Estate	05/97-			315 083 600 001	→		60	19.1	7.6	80	1400		300 060 300 107			--	C2	--	E1	--	--	H	45	B
													300 060 300 113			--	C2	--	E1	D1	L1	H	45	B





























Peugeot 307 Convertible / CC	10/03-			315 167 600 001			120	19.0	8.4	80	1500		300 210 300 107			--	A	--	--	--	--	V		B
													300 210 300 113			--	A	--	E1	D1	L1	V	90	B
Peugeot 307 Hatchback	06/01-			315 108 600 001			60	19.0	9.1	80	1700		300 072 300 107	-07/05	--	FRE	--	--	--	--	--	V		B
													300 072 300 113	-07/05	--	FRE	--	--	D1	L1	V		B	
													304 401 300 107	07/05-	S	CAN	C1	E	--	--	H	105	B	
													304 401 300 113		S	CAN	C1	E	D	L1	H	105	B	
Peugeot 307 Hatchback	07/05-	KIT		315 108 900 113			60	21.0	9.1	80	1700		included in the KIT			S	CAN	C1	E	D	L1	H	105	B
																KIT		315 109 900 113			60	23.0	9.1	80
Peugeot 307 SW 7 seats and minibus	06/02-			315 099 600 001			45	19.0	9.1	60	1700		300 072 300 107	-07/05	--	FRE	--	--	--	--	V		B	
													300 072 300 113	-07/05	--	FRE	--	--	D1	L1	V		B	
													304 401 300 107	07/05-	S	CAN	C1	E	--	--	H	105	B	
													304 401 300 113		S	CAN	C1	E	D	L1	H	105	B	
Peugeot 307 SW 7 seats and minibus	07/05-	KIT		315 099 900 113			45	21.0	9.1	60	1700		included in the KIT			S	CAN	C1	E	D	L1	H	105	B
																KIT		315 103 900 113			45	23.0	9.1	60
Peugeot 308 Hatchback exc. GTi / 200 HP	10/07-05/11			315 109 600 001			60	21.0	9.1	80	1700		315 109 300 107			S	CAN	C	E	--	--	V	105	B
													315 109 300 113		S	CAN	C	E	D	L1	V	105	B	
Peugeot 308 Hatchback exc. Gti (200 HP), Premium,vehicles with sport rear bumper	05/11-09/13			315 188 600 001			60	22.0	9.1	80	1700		315 109 300 107			S	CAN	C	E	--	--	V	105	B
													315 109 300 113		S	CAN	C	E	D	L1	V	105	B	
		KIT		315 188 900 113			60	24.0	9.1	80	1700		included in the KIT			S	CAN	C	E	D	L1	V	105	B























Peugeot

Peugeot 308 Hatchback	09/13-			304 151 600 001		90	21.0	9.5	75	1750		304 152 300 107			S	CAN	C	E	--	--		105	B
				304 152 600 001		90	24.0	9.5	75	1750		304 152 300 113			S	CAN	C	E	D1	L1		105	B
		KIT		304 151 900 113			21.0	9.5	75	1750		included in the KIT			S	CAN	C	E	D1	L1		105	B
		KIT		304 152 900 113		90	24.0	9.5	75	1750						S	CAN	C	E	D1	L1		105
Peugeot 308 cc, Convertible	03/09-			315 150 600 001		120	22.6	8.4	80	1500		315 109 300 107			S	CAN	C	E	--	--	V	105	B
												315 109 300 113			S	CAN	C	E	D	L1	V	105	B
Peugeot 308 SW	05/08-05/14			315 151 600 001		120	17.6	9.5	74	1700		315 109 300 107			S	CAN	C	E	--	--	V	105	B
				315 152 600 001		120	22.0	9.5	74	1700		315 109 300 113			S	CAN	C	E	D	L1	V	105	B
		KIT		315 151 900 113		120	19.6	9.5	74	1700		included in the KIT			S	CAN	C	E	D	L1	V	105	B
		KIT		315 152 900 113		120	24.0	9.5	74	1700						S	CAN	C	E	D	L1	V	105
Peugeot 308 SW	05/14-			304 151 600 001		90	21.0	9.5	75	1750		315 196 300 107			S	CAN	C	E2	--	--	V	75	B
				304 152 600 001		90	24.0	9.5	75	1750		315 196 300 113			S	CAN	C	E2	D	L1	V	75	L
		KIT		315 195 900 113		90	21.0	9.5	75	1750		included in the KIT			S	CAN	C	E2	D	L1	V	75	L
		KIT		315 196 900 113		90	24.0	9.5	75	1750						S	CAN	C	E2	D	L1	V	75





Peugeot 4007	09/07-			340 094 600 001		90	27.0	10.9	100	2000		340 075 300 113			S	FRE	--	E	D	L	H	75	B
		KIT		340 094 900 113		90	29.0	10.9	100	2000		included in the KIT			S	FRE	--	E	D	L	H	75	B
Peugeot 4008	03/12-			340 092 600 001		90	22.0	8.5	70	1400		340 093 300 113			S	A	--	--	D	L	H	60	B
				340 093 600 001		90	24.0	8.5	70	1400						S	A	--	--	D	L	H	60
		KIT		340 092 900 113		90	24.0	8.5	70	1400		included in the KIT			S	A	--	--	D	L	H	60	B
		KIT		340 093 900 113		90	26.0	8.5	70	1400						S	A	--	--	D	L	H	60
Peugeot 407 Coupé	06-			315 168 600 001		120	27.0	9.2	85	1600		304 401 300 107			S	CAN	C1	E	--	--	H	105	B
												304 401 300 113			S	CAN	C1	E	D	L1	H	105	B
Peugeot 407 Estate / SW	01/05-			304 146 600 001		120	22.0	10.4	80	1900		304 401 300 107		-07/08 OPR 11557	S	CAN	C1	E	--	--	H	105	B
				304 145 600 001		120	24.5	10.4	80	1900		304 401 300 113		-07/08 OPR 11557	S	CAN	C1	E	D	L1	H	105	B
Peugeot 407 Estate / SW	01/05-07/08	KIT		315 104 900 113		120	24.0	10.4	80	1900		included in the KIT		-07/08 OPR 11557	S	CAN	C1	E	D	L1	H	105	B
		KIT		315 105 900 113		120	26.5	10.4	80	1900						S	CAN	C1	E	D	L1	H	105
Peugeot 407 Saloon	05/04-			304 145 600 001		120	24.5	10.4	80	1900		304 401 300 107		-07/08 OPR 11557	S	CAN	C1	E	--	--	H	105	B
												304 401 300 113		-07/08 OPR 11557	S	CAN	C1	E	D	L1	H	105	B
Peugeot 407 Saloon exc. vehicles with park distance control	05/04-			304 146 600 001		120	22.0	10.4	80	1900		304 401 300 107		-07/08 OPR 11557	S	CAN	C1	E	--	--	H	105	B
												304 401 300 113		-07/08 OPR 11557	S	CAN	C1	E	D	L1	H	105	B









Peugeot

Peugeot 407 Saloon exc. vehicles with park distance control	05/04-07/08	KIT		315 104 900 113		120	24.0	10.4	80	1900		included in the KIT		-07/08 OPR 11557	S	CAN	C1	E	D	L1	H	105	B	
Peugeot 407 Saloon	05/04-07/08	KIT		315 105 900 113		120	26.5	10.4	80	1900		included in the KIT		-07/08 OPR 11557	S	CAN	C1	E	D	L1	H	105	B	
Peugeot 5008	09/09-			315 177 600 001		120	21.0	10.0	75	1550		304 400 300 107		-12/11	S	CAN	C1	E	--	--	H	105	B	
				315 179 600 001	→ 	90	21.0	10.0	75	1550		304 400 300 113		-12/11	S	CAN	C1	E	D	L1	H	105	B	
				315 178 600 001		90	22.5	9.7	80	1700		315 109 300 107		01/12-03/14	S	CAN	C	E	--	--	V	105	B	
												315 109 300 113		01/12-03/14	S	CAN	C	E	D	L1	V	105	B	
												315 110 300 107		03/14-	S	CAN	C	E	--	--	V	60	B	
											315 110 300 113		03/14-	S	CAN	C	E	D	L1	V	60	B		
Peugeot 5008 01/12-03/14	01/12-03/14	KIT		315 177 900 113		120	23.0	10.0	75	1550		included in the KIT		01/12-03/14	S	CAN	C	E	D	L1	V	105	B	
		KIT		315 178 900 113		90	24.5	9.7	80	1700														
Peugeot 508 Estate exc. GT/twin exhaust models exc. RXH	03/11-			315 180 600 001		90	20.5	10.2	75	1900		315 182 300 113			S	CAN	C	E	D	L	H		B	
				315 182 600 001		90	20.5	10.2	75	1900														
		KIT		315 180 900 113		90	22.5	10.2	75	1900		included in the KIT			S	CAN	C	E	D	L	H			B
		KIT		315 182 900 113		90	22.5	10.2	75	1900														
Peugeot 508 Saloon exc. GT/twin exhaust models	03/11-			315 175 600 001		90	20.5	10.2	75	1900		315 182 300 113			S	CAN	C	E	D	L	H		B	
		KIT		315 175 900 113		90	22.5	10.2	75	1900		included in the KIT			S	CAN	C	E	D	L	H			B
Peugeot 607	00-			315 090 600 001	→ 	180	23.2	9.8	72	1800		300 210 300 107			--	A	--	--	--	--	--	V		B
												300 210 300 113			--	A	--	E1	D1	L1	V	90	B	









Peugeot 607	11/00-		315 169 600 001		120	25.0	9.9	80	1800	300 210 300 107			--	A	--	--	--	V		B							
																			--	A	--	E1	D1	L1	V	90	B
Peugeot 806	09/94-08/02		315 072 600 001	→ 	60	16.4	10.9	100	2000	300 060 300 107			--	C2	--	E1	--	H	45	B							
																		--	C2	--	E1	D1	L1	H	45	B	
Peugeot 807	09/02-		315 098 600 001		75	19.8	10.8	100	1900	304 400 300 107	10/05-		S	CAN	C1	E	--	H	105	B							
															S	CAN	C1	E	D	L1	H	105	B				
			315 097 600 001		75	22.0	10.8	100	1900	315 097 300 107	→ 	-09/05		S	FRE	--	E	--	H	45	B						
																→ 	-09/05	S	FRE	--	E	D1	L1	H	45	B	
Peugeot 807	10/05-	KIT 	315 098 900 113		75	21.8	10.8	100	1900	included in the KIT			S	CAN	C1	E	D	L1	H	105	B						
					KIT 	315 097 900 113		75	24.0				10.8	100	1900												
Peugeot Bipper + Teepee exc. vehicles with gas drive	02/08-		306 349 600 001		150	16.5	7.5	75	1300	306 580 300 107			S	FRE	--	E	--	V	120	B							
						306 351 600 001		150	17.0				7.5	75	1300	306 580 300 113			S	FRE	--	E	D1	L1	V	120	B
									306 350 600 001					150	17.0				7.5	75	1300						
		KIT 	306 349 900 113		150	18.5	7.5	75	1300	included in the KIT				S	FRE	--	E	D1	L1	V	120	B					
					KIT 	306 350 900 113		150	19.0					7.5	75	1300											

















Peugeot

Peugeot Boxer Van inc. 4 WD exc. vehicles with gas bottle instead of the spare wheel 4 WD: bolt kit (order no. 906216650002) must be ordered separately. Towball for vehicles with standard chassis: 329089600001 (not included). Towball for vehicles with 16" wheels and reinforced springs: 329062600001 (not included). When mounting swap system to vehicles with standard chassis we recommend towball 329059600001 (not included).	03/94-06/06			306 216 600 001			60	32.7	13.3	150	2500		306 142 300 113	→		S	C2	--	E1	D1	L1	H	45	L
				306 216 300 113										03/02-	S	FRE	--	E	D1	L1	V	75	B	
Peugeot Boxer Van inc. towball	08/99-06/06			306 329 600 001				29.0	12.5	130	2000		306 142 300 113	→		S	C2	--	E1	D1	L1	H	45	L
				306 216 300 113										03/02-	S	FRE	--	E	D1	L1	V	75	B	
Peugeot Boxer Van For vehicles with long superstructure L4/XL please order separately a set distance tubes to strengthen the framework, no. 906270650003. Some vehicles 03/08- do not have chassis bores. In this case it is necessary to bore them subsequent. For the mounting time will last 120 min. longer.	06/06-			306 271 600 001			60	32.0	16.9	150	3000		306 271 300 107	02/11- from chassis no. 1948841	S	FRE	--	E	--	--	V	105	B	
				306 271 300 113									306 271 300 113	02/11- from chassis no. 1948841	S	FRE	--	E	D1	L1	V	105	B	
				306 510 300 107									306 510 300 107	-02/11 chassis no. 1948840	S	FRE	--	E	--	--	V	105	B	
				306 510 300 113									306 510 300 113	-02/11 chassis no. 1948840	S	FRE	--	E	D1	L1	V	105	B	
Peugeot Boxer Van van / minibus For vehicles with long superstructure L4/XL please order separately a set distance tubes to strengthen the framework, no. 906270650003. Some vehicles 03/08- do not have chassis bores. In this case it is necessary to bore them subsequent. For the mounting time will last 120 min. longer.	06/06-02/11	KIT		306 271 900 113			60	34.0	16.9	150	3000		included in the KIT	-02/11 chassis no. 1948840	S	FRE	--	E	D1	L1	V	105	B	











Peugeot Boxer Van For vehicles with long superstructure L4/XL please order separately a set distance tubes to strengthen the framework, no. 906270650003. Some vehicles 03/08- do not have chassis bores. In this case it is necessary to bore them subsequent. For the mounting time will last 120 min. longer.	02/11-	KIT		306 272 900 113		60	34.0	16.9	150	3000				included in the KIT		02/11- from chassis no. 1948841	S	FRE	--	E	D1	L1	V	105	B
Peugeot Boxer Van inc. towball For vehicles with long superstructure L4/XL please order separately a set distance tubes to strengthen the framework, no. 906270650003. Some vehicles 03/08- do not have chassis bores. In this case it is necessary to bore them subsequent. For the mounting time will last 120 min. longer.	06/06-			306 357 600 001		60	21.0	15.8	150	3000		306 271 300 107	02/11- from chassis no. 1948841	S	FRE	--	E	--	--	V	105	B			
												306 271 300 113	02/11- from chassis no. 1948841	S	FRE	--	E	D1	L1	V	105	B			
												306 510 300 107	-02/11 chassis no. 1948840	S	FRE	--	E	--	--	V	105	B			
												306 510 300 113	-02/11 chassis no. 1948840	S	FRE	--	E	D1	L1	V	105	B			
Peugeot Boxer Van inc. towball 329059600001 For vehicles with long superstructure L4/XL please order separately a set distance tubes to strengthen the framework, no. 906270650003. Some vehicles 03/08- do not have chassis bores. In this case it is necessary to bore them subsequent. For the mounting time will last 120 min. longer.	06/06-			306 330 600 001		60	32.0	16.9	150	3000		306 271 300 107	02/11- from chassis no. 1948841	S	FRE	--	E	--	--	V	105	B			
												306 271 300 113	02/11- from chassis no. 1948841	S	FRE	--	E	D1	L1	V	105	B			
												306 510 300 107	-02/11 chassis no. 1948840	S	FRE	--	E	--	--	V	105	B			
												306 510 300 113	-02/11 chassis no. 1948840	S	FRE	--	E	D1	L1	V	105	B			
Peugeot Boxer Van inc. towball 329059600001 For vehicles with long superstructure L4/XL please order separately a set distance tubes to strengthen the framework, no. 906270650003. Some vehicles 03/08- do not have chassis bores. In this case it is necessary to bore them subsequent. For the mounting time will last 120 min. longer.	06/06-02/11	KIT		306 330 900 113		60	34.0	16.9	150	3000			included in the KIT		-02/11 chassis no. 1948840	S	FRE	--	E	D1	L1	V	105	B	













Peugeot

Peugeot Boxer Van inc. towball 329059600001 For vehicles with long superstructure L4/XL please order separately a set distance tubes to strengthen the framework, no. 906270650003. Some vehicles 03/08- do not have chassis bores. In this case it is necessary to bore them subsequent. For the mounting time will last 120 min. longer.	02/11-	KIT		306 357 900 113			60	34.0	16.9	150	3000		included in the KIT		02/11- from chassis no. 1948841	S	FRE	--	E	D1	L1	V	105	B
Peugeot Boxer Chassis Cab inc. 4 WD exc. vehicles with gas bottle instead of the spare wheel 4 WD: bolt kit (order no. 906216650002) must be ordered separately. Towball for vehicles with standard chassis: 329089600001 (not included). Towball for vehicles with 16" wheels and reinforced springs: 329062600001 (not included). When mounting swap system to vehicles with standard chassis we recommend towball 329059600001 (not included).	03/94-06/06			306 216 600 001			60	32.7	13.3	150	2500		300 052 300 107 300 052 300 113 300 060 300 113		03/02- 03/02- -03/02	--	FRE	--	E1	--	--	V		B B B
Peugeot Boxer Chassis Cab inc. towball	08/99-06/06			306 329 600 001				29.0	12.5	130	2000		300 052 300 107 300 052 300 113 300 060 300 113		03/02- 03/02- -03/02	--	FRE	--	E1	--	--	V		B B B
Peugeot Boxer Chassis Cab inc. towball 329059600001. For vehicles with long superstructure L4/XL please order separately a set distance tubes to strengthen the framework, no. 906270650003.	06/06-			306 318 600 001			60	30.5	15.9	150	3000		306 531 300 107 306 531 300 113			S	FRE	--	E1	--	--	V	90	L L
Peugeot Boxer Chassis Cab inc. towball For vehicles with long superstructure L4/XL please order separately a set distance tubes to strengthen the framework, no. 906270650003.	06/06-	KIT		306 318 900 113			60	32.5	15.9	150	3000		included in the KIT			S	FRE	--	E1	D	--	V	90	L
Peugeot Boxer Chassis Cab inc. towball For vehicles with long superstructure L4/XL please order separately a set distance tubes to strengthen the framework, no. 906270650003.	06/06-			306 357 600 001			60	21.0	15.8	150	3000		306 531 300 107 306 531 300 113			S	FRE	--	E1	--	--	V	90	L L















Peugeot Boxer Chassis Cab combined universal HGV towbar for towballs and coupling bolt inc. towball 329059600001. For vehicles with long superstructure L4/XL please order separately a set distance tubes to strengthen the framework, order no. 906270650003. Please order separately coupling bolt 342090600001.	06/06-		306 359 600 001			90	40.0	12.5	150	2000		306 531 300 107			S	FRE	--	E1	--	--	V	90	L
												306 531 300 113			S	FRE	--	E1	D	--	V	90	L
Peugeot Expert	09/94-01/07		315 072 600 001	→		60	16.4	10.9	100	2000		300 060 300 107	-07/97	--	C2	--	E1	--	--	H	45	B	
												300 060 300 113	-07/97	--	C2	--	E1	D1	L1	H	45	B	
												306 155 300 113	08/97-	S	C2	--	E1	D	--	H	45	L	
Peugeot Expert	01/07-		306 331 600 001			75	22.5	12.2	122	2200		304 400 300 107			S	CAN	C1	E	--	--	H	105	B
			306 333 600 001					75	22.5	12.2		122			2200	304 400 300 113	S	CAN	C1	E	D	L1	H
		KIT		306 331 900 113		75	22.5	12.2	122	2200	included in the KIT			S	CAN	C1	E	D	L1	H	105	B	
			KIT		306 333 900 113		75	24.5	12.2	122													2200
Peugeot Partner Van	11/96-04/08		304 054 600 001			90	14.8	7.8	70	1350		304 054 300 113			S	FRE	--	E1	D1	--	V	75	L
			KIT				304 054 900 113		90	16.8		7.8			70	1350	included in the KIT	S	FRE	--	E1	D1	--
Peugeot Partner Van long superstructure + Tepee, vehicle length = 4628 mm	08-		304 129 600 001			90	16.3	8.7	64	1600		304 400 300 107	-11/11- OPR 12776		S	CAN	C1	E	--	--	H	105	B
			304 131 600 001			90	19.0	8.7	64	1600		304 400 300 113											
			304 402 300 107			11/11- OPR 12775	S	CAN	C1	E	--	--	V	105	B								
			304 402 300 113			11/11- OPR 12775	S	CAN	C1	E	D	L1	V	105	B								

















Peugeot

Peugeot Partner Van long superstructure + Tepee, vehicle length = 4628 mm	08-11/11	KIT		304 129 900 113			90	18.3	8.7	64	1600		included in the KIT				S	CAN	C1	E	D	L1	H	105	B
		KIT		304 131 900 113			90	21.0	8.7	64	1600														
Peugeot Partner Van short superstructure + Tepee, vehicle length = 4380 mm	04/08-			304 091 600 001			90	15.0	8.7	64	1600		304 400 300 107	-11/11 OPR 12776	S	CAN	C1	E	--	--	H	105	B		
				304 092 600 001			90	19.0	8.7	64	1600		304 400 300 113		S	CAN	C1	E	D	L1	H	105	B		
													304 402 300 107	11/11- OPR 12775	S	CAN	C1	E	--	--	V	105	B		
													304 402 300 113	11/11- OPR 12775	S	CAN	C1	E	D	L1	V	105	B		
Peugeot Partner Van short superstructure + Tepee, vehicle length = 4380 mm	04/08-11/11	KIT		304 091 900 113			90	17.0	8.7	64	1600		included in the KIT				S	CAN	C1	E	D	L1	H	105	B
		KIT		304 092 900 113			90	21.0	8.7	64	1600														
Peugeot Partner Origin	04/08-			304 054 600 001			90	14.8	7.8	70	1350		304 054 300 113		S	FRE	--	E1	D1	--	V	75	L		
		KIT		304 054 900 113			90	16.8	7.8	70	1350		included in the KIT		S	FRE	--	E1	D1	--	V	75	L		















Porsche Cayenne exc. vehicles with spare wheel on the tailgate	12/02-		321 735 600 001		150	33.5	16.4	140	3500		321 500 300 113	-04/10	S	CAN	--	E	D	L1	H	45	B	
											321 765 300 107	04/10-	S	CAN	C	E	D	L1	V	180	B	
											321 765 300 113	04/10-	S	CAN	C	E	D	L1	V	180	B	
Porsche Cayenne models 12/02-04/10: Please order separately cover for bumper cutout at Porsche dealer' s. exc. vehicles with spare wheel on the tailgate	12/02-		321 736 600 001		150	34.0	16.4	140	3500		321 500 300 113	-04/10	S	CAN	--	E	D	L1	H	45	B	
											321 765 300 107	04/10-	S	CAN	C	E	D	L1	V	180	B	
											321 765 300 113	04/10-	S	CAN	C	E	D	L1	V	180	B	
Porsche Cayenne Please order separately cover for bumper cutout at Porsche dealer' s. exc. vehicles with spare wheel on the tailgate	12/02-04/10	KIT		321 500 900 113		150	36.0	16.4	140	3500		included in the KIT	-04/10	S	CAN	--	E	D	L1	H	45	B
Porsche Cayenne exc. vehicles with spare wheel on the tailgate	04/10-	KIT		321 736 900 113		150	36.0	16.4	140	3500		included in the KIT	04/10-	S	CAN	C	E	D	L1	V	180	B
Porsche Macan	04/14-			327 068 600 001		90	21.0	12.1	100	2400		327 068 300 113		S	CAN	C	E	D	L1			B
		KIT		327 068 900 113		90	23.0	12.1	100	2400		included in the KIT		S	CAN	C	E	D	L1			B















Renault

Renault Captur	05/13-		316 354 600 001			90	14.0	7.1	75	1200		316 337 300 107			S	A	--	E2			V	90	B
			316 355 600 001			90	16.0	7.1	75	1200		316 337 300 113			S	A	--	E2	D1	L1	V	90	B
	KIT		316 354 900 113			90	16.0	7.1	75	1200		included in the KIT			S	A	--	E2	D1	L1	V	90	B
			316 355 900 113			90	18.0	7.1	75	1200						S	A	--	E2	D1	L1	V	90
Renault Clio II Phase I + II, exc. Phase IV, exc. Clio Sport V6	09/98-10/05		316 187 600 001			90	14.5	6.2	75	1200		300 072 300 113		-05/01 (Phase I)	--	FRE	--	--	D1	L1	V		B
Renault Clio III Phase I + II exc. Clio Sport 197/201 HP exc. RS-Cup exc. GT	10/05-		316 354 600 001			90	14.0	7.1	75	1200		316 252 300 113			S	FRE	--	--	D1	L1	H	45	B
			316 355 600 001			90	16.0	7.1	75	1200						S	FRE	--	--	D1	L1	H	45
	KIT		316 251 900 113			60	15.0	7.1	75	1200		included in the KIT			S	FRE	--	--	D1	L1	H	45	B
			316 252 900 113			90	17.0	7.1	75	1200						S	FRE	--	--	D1	L1	H	45
Renault Clio III Grandtour	01/08-		316 277 600 001			90	18.0	7.0	75	1200		316 252 300 113			S	FRE	--	--	D1	L1	H	45	B
			316 278 600 001			90	21.0	7.0	75	1200						S	FRE	--	--	D1	L1	H	45
	KIT		316 277 900 113			90	20.0	7.0	75	1200		included in the KIT			S	FRE	--	--	D1	L1	H	45	B
			316 278 900 113			90	23.0	7.0	75	1200						S	FRE	--	--	D1	L1	H	45

Renault Clio IV Hatchback exc. GT	11/12-		316 355 600 001			90	16.0	7.1	75	1200		316 337 300 107			S	A	--	E2			V	90	B	
												316 337 300 113			S	A	--	E2	D1	L1	V	90	B	
		KIT		316 355 900 113			90	18.0	7.1	75	1200		included in the KIT			S	A	--	E2	D1	L1	V	90	B
Renault Clio IV Grandtour	03/13-		316 336 600 001			60	15.0	7.1	75	1200		316 337 300 107			S	A	--	E2			V	90	B	
			316 337 600 001			60	18.0	7.1	75	1200		316 337 300 113			S	A	--	E2	D1	L1	V	90	B	
		KIT		316 336 900 113			60	17.0	7.1	75	1200		included in the KIT			S	A	--	E2	D1	L1	V	90	B
		KIT		316 337 900 113			60	20.0	7.1	75	1200						S	A	--	E2	D1	L1	V	90
Renault Espace short wheelbase	09/02-		316 195 600 001			55	31.0	11.3	80	2000		300 078 300 113			--	FRE	--	--	D1	L1	V		B	
			316 194 600 001			55	31.0	11.3	80	2000														
Renault Espace / Grand Espace exc. vehicles with automatic height control	01/97-09/02		316 102 600 001	→		90	12.0	11.8	85	2300		300 078 300 113			--	FRE	--	--	D1	L1	V		B	
Renault Espace / Grand Espace long wheel base	09/02-		316 191 600 001			55	31.0	11.3	80	2000		300 078 300 113			--	FRE	--	--	D1	L1	V		B	
			316 192 600 001			55	31.0	11.3	80	2000														
Renault Fluence	03/10-		316 308 600 001			120	22.5	7.5	75	1300		300 210 300 107			--	A	--	--	--	--	V		B	
			316 322 600 001	→		120	23.7	7.5	75	1300		300 210 300 113			--	A	--	E1	D1	L1	V	90	B	













Renault







Renault Grand Kangoo 7 seats	02/08-			316 268 600 001			60	23.0	8.2	75	1350		316 353 300 107	05/13-	S	FRE	--	--	--	H	60	L		
				316 269 600 001			60	23.0	8.2	75	1350		316 353 300 113	05/13-	S	FRE	--		D1	L1	H	60	L	
													316 440 300 113	-04/13 exc. vehicles with start-/stop automatic	S	FRE	--	E2	D1	L1	H	45	L	
Renault Grand Kangoo 7 seats	02/08-04/13	KIT		316 268 900 113			60	25.0	8.2	75	1350		included in the KIT		S	FRE	--	E2	D1	L1	H	45	L	
				316 269 900 113			60	25.0	8.2	75	1350													
Renault Grand Kangoo 7 seats	05/13-	KIT		316 352 900 113			60	25.0	8.2	75	1350		included in the KIT	05/13-	S	FRE	--		D1	L1	H	60	L	
				316 353 900 113			60	25.0	8.2	75	1350													
Renault Grand Modus exc. vehicles with rear end carrier system Velofix	01/08-			316 354 600 001			90	14.0	7.1	75	1200		300 210 300 113		--	A	--	E1	D1	L1	V	90	B	
				316 355 600 001			90	16.0	7.1	75	1200													
Renault Grand Scenic	04/09-			316 295 600 001			90	18.5	8.2	75	1300		316 297 300 107		S	A	--	--	--	--	H	60	B	
				316 297 600 001			90	21.4	8.2	75	1300		316 297 300 113		S	A	--	--	D1	L1	H	60	B	
			KIT		316 295 900 113			90	20.5	8.2	75	1300		included in the KIT		S	A	--	--	D1	L1	H	60	B
			KIT		316 297 900 113			90	23.4	8.2	75	1300												
Renault Kangoo exc. Kangoo-Rapid-Maxi Campus without limitation of year of construction	05/97-02/08			316 201 600 001			60	12.0	7.6	75	1320		316 205 300 107		S	A	--	--	D1	--	H	45	B	
												316 205 300 113		S	A	--	--	D1	--	H	45	B		
			KIT		316 201 900 113			60	14.0	7.6	75	1320		included in the KIT		S	A	--	--	D1	--	H	45	B

Renault Kangoo RX4, 4x4/Pampa/Freeworld exc. Kangoo Rapid	06/01-02/08		316 205 600 001			60	12.0	7.6	75	1320		316 205 300 107			S	A	--	--	D1	--	H	45	B											
												316 205 300 113			S	A	--	--	D1	--	H	45	B											
Renault Kangoo + Kangoo Rapid exc. BeBop	02/08-		316 268 600 001			60	23.0	8.2	75	1350		316 353 300 107	05/13-	S	FRE	--	--	--	D1	L1	H	60	L											
				316 269 600 001			60	23.0	8.2	75	1350													316 353 300 113	05/13-	S	FRE	--		D1	L1	H	60	L
					316 440 300 113																				-04/13 exc. vehicles with start-/stop automatic	S	FRE	--	E2	D1	L1	H	45	L
Renault Kangoo + Kangoo Rapid exc. BeBop	02/08-04/13	KIT 	316 268 900 113			60	25.0	8.2	75	1350		included in the KIT			S	FRE	--	E2	D1	L1	H	45	L											
			KIT 	316 269 900 113			60	25.0	8.2	75	1350																							
Renault Kangoo + Kangoo Rapid exc. BeBop	05/13-	KIT 	316 352 900 113			60	25.0	8.2	75	1350		included in the KIT		05/13-	S	FRE	--		D1	L1	H	60	L											
			KIT 	316 353 900 113			60	25.0	8.2	75	1350																							
Renault Kangoo BeBop	02/09-		316 316 600 001			90	20.0	7.2	75	1100		316 353 300 107	06/13-	S	FRE	--	--	--	D1	L1	H	60	L											
												316 353 300 113												06/13-	S	FRE	--		D1	L1	H	60	L	
												316 440 300 113												-05/13	S	FRE	--	E2	D1	L1	H	45	L	
Renault Koleos inc. Phase I + II 09/11-	09/08-		316 226 600 001			40	21.7	10.5	100	2000		316 410 300 113			S	FRE	--	--	D1	L1	H	60	L											
				316 227 600 001			40	23.8	10.5	100	2000																							
		KIT 	316 226 900 113			40	23.0	10.5	100	2000		included in the KIT			S	FRE	--	--	D1	L1	H	60	L											
			KIT 	316 227 900 113			40	25.0	10.5	100	2000																							
Renault Laguna Coupé exc. GT 4 control	01/09-		316 267 600 001			60	20.5	9.8	75	1700		300 210 300 113			--	A	--	E1	D1	L1	V	90	B											
Renault Laguna Grandtour exc. vehicles with automatic height control	09/95-03/01		316 127 600 001	→		90	19.6	9.1	75	2100		300 210 300 107	with bordcomputer	--	A	--	--	--	D1	L1	V	90	B											
												300 210 300 113												with bordcomputer	--	A	--	E1	D1	L1	V	90	B	



















Renault









Renault

Renault Laguna Grandtour estate	03/01-01/08		316 155 600 001		40	19.0	8.5	75	1500		300 210 300 107	with bordcomputer	--	A	--	--	--	--	V		B	
											300 210 300 113	with bordcomputer	--	A	--	E1	D1	L1	V	90	B	
Renault Laguna Grandtour exc. GT 4 control	01/08-		316 264 600 001		60	19.0	9.8	75	1700		316 430 300 107		S	A	--	E	--	--	H	45	L	
												316 265 600 001		60	20.0	9.8	75	1700		316 430 300 113		S
		KIT		316 264 900 113		60	21.0	9.8	75	1700				S	A	--	E	D1	L1	H	45	L
			KIT		316 265 900 113		60	22.0	9.8	75	1700		included in the KIT		S	A	--	E	D1	L1	H	45
Renault Laguna I Hatchback	04/94-02/01		316 106 600 001	→	90	17.6	8.9	75	1650		300 072 300 107		--	FRE	--	--	--	--	V		B	
											300 072 300 113		--	FRE	--	--	D1	L1	V		B	
											300 210 300 107		--	A	--	--	--	--	V		B	
											300 210 300 113		--	A	--	E1	D1	L1	V	90	B	
Renault Laguna II Saloon	03/01-09/07		316 178 600 001	→	40	21.0	8.5	75	1500		300 072 300 107	without bordcomputer	--	FRE	--	--	--	--	V		B	
											300 072 300 113	without bordcomputer	--	FRE	--	--	D1	L1	V		B	
											300 210 300 107	with bordcomputer	--	A	--	--	--	--	V		B	
											300 210 300 113	with bordcomputer	--	A	--	E1	D1	L1	V	90	B	
Renault Laguna III Hatchback exc. GT 4 control	09/07-		316 261 600 001	→	60	19.0	8.8	75	1500		300 210 300 107		--	A	--	--	--	V		B		
												316 262 600 001		60	22.0	8.8	75	1500		300 210 300 113		--
Renault Latitude, L43	01/11-		316 310 600 001	→	120	20.6	8.3	75	1400		300 210 300 107		--	A	--	--	--	V		B		
												300 210 300 113		--	A	--	E1	D1	L1	V	90	B
Renault Mascott van / minibus inc. Master Maxi 07-			316 255 600 001	→	120	32.0	15.8	80	3000		300 210 300 107		--	A	--	--	--	V		B		
											300 210 300 113		--	A	--	E1	D1	L1	V	90	B	







Renault Master Van exc. Master Maxi	01/98-		316 124 600 001			60	28.5	13.7	85	2300		300 052 300 107	-11/03	--	FRE	--	E1	--	--	V		B
												300 052 300 113	-11/03	--	FRE	--	E1	D1	--	V		B
												316 130 300 113	11/03-	S	FRE	--	--	D1	L1	H	45	L
Renault Master Van inc. towball 329057600001 When mounting the swap system please order towball order no. 329059600001. exc. Master Maxi	01/98-		316 126 600 001			60	29.8	15.3	80	2800		300 052 300 107	-11/03	--	FRE	--	E1	--	--	V		B
												300 052 300 113	-11/03	--	FRE	--	E1	D1	--	V		B
												316 130 300 113	11/03-	S	FRE	--	--	D1	L1	H	45	L
Renault Master Van front wheel drive	03/10-		316 318 600 001			60	19.3	14.3	100	2500		316 300 300 107	for vehicles without central plug connection	S	FRE	--	E1	--	--	H	45	B
												316 300 300 113	for vehicles without central plug connection	S	FRE	--	E1	D1	L1	H	45	B
												316 318 300 113	for vehicles with central plug connection	S	FRE	--	E2	D1	L1	H	15	B
Renault Master Van rear wheel drive	03/10-		316 327 600 001			60	19.7	14.3	100	2500		316 300 300 107	for vehicles without central plug connection	S	FRE	--	E1	--	--	H	45	B
												316 300 300 113	for vehicles without central plug connection	S	FRE	--	E1	D1	L1	H	45	B
												316 318 300 113	for vehicles with central plug connection	S	FRE	--	E2	D1	L1	H	15	B
Renault Master Van rear wheel drive with twin wheels	03/10-		316 328 600 001			60	19.7	15.8	100	3000		316 300 300 107	for vehicles without central plug connection	S	FRE	--	E1	--	--	H	45	B
												316 300 300 113	for vehicles without central plug connection	S	FRE	--	E1	D1	L1	H	45	B
												316 318 300 113	for vehicles with central plug connection	S	FRE	--	E2	D1	L1	H	15	B
Renault Master Chassis Cab inc. towball 329057600001 When mounting the swap system please order towball order no. 329059600001.	01/98-		316 126 600 001			60	29.8	15.3	80	2800		300 052 300 107	-10/03	--	FRE	--	E1	--	--	V		B
												300 052 300 113	-10/03	--	FRE	--	E1	D1	--	V		B
												316 135 300 113	11/03-	S	A	--	E1	D1	--	H	45	L
Renault Master Chassis Cab front + rear wheel drive	07/10-		316 319 600 001			60	16.0	14.3	100	2500		316 319 300 113	for vehicles with preparation	S	FRE	--	E1	D1	--	H	15	B

















Renault

Renault Master Chassis Cab rear wheel drive with twin wheels	07/10-		316 329 600 001			60	15.0	15.8	100	3000		316 319 300 113	for vehicles with preparation	S	FRE	--	E1	D1	--	H	15	B	
Renault Maxity towball 329059600001 inc.	07-		332 273 600 001			60	22.5	19.4	150	3500		300 201 300 113		--	A	--	E1	D1	--	V		B	
Renault Mégane 5 doors	11/08-		316 272 600 001	→		120	19.1	8.1	75	1350		316 273 300 107		S	A	--	--	--	--	H	60	B	
			316 352 600 001			120	18.0	8.7	75	1500													
			316 273 600 001	→		120	21.5	8.1	75	1350		316 273 300 113		S	A	--	--	D1	L1	H	60	B	
			316 363 600 001			120	21.0	8.7	75	1500													
		KIT 	316 272 900 113			120	21.0	8.1	75	1350			included in the KIT		S	A	--	--	D1	L1	H	60	B
KIT 	316 273 900 113			120	23.5	8.1	75	1350															
Renault Mégane Coupé exc. Sport 250 HP exc. GT-Line	11/08-		316 272 600 001	→		120	19.1	8.1	75	1350		300 210 300 107		--	A	--	--	--	--	V		B	
			316 273 600 001	→		120	21.5	8.1	75	1350		300 210 300 113		--	A	--	E1	D1	L1	V	90	B	
Renault Mégane Coupé exc. Sport 250 HP exc. GT-Line	01/09-		316 352 600 001			120	18.0	8.7	75	1500		300 210 300 107		--	A	--	--	--	--	V		B	
			316 363 600 001			120	21.0	8.7	75	1500		300 210 300 113		--	A	--	E1	D1	L1	V	90	B	
Renault Mégane Hatchback 5 doors inc.Phase II exc.Coach, convertible	01/96-10/02		316 107 600 001	→		90	15.8	7.6	75	1350		300 072 300 107		--	FRE	--	--	--	--	V		B	
												300 072 300 113		--	FRE	--	--	D1	L1	V		B	















Renault Mégane Hatchback 3 / 5 doors	11/02-11/08		316 175 600 001	→ 	60	18.0	7.6	75	1350	300 072 300 107					--	FRE	--	--	--	--	V	B															
			316 352 600 001		120	18.0	8.7	75	1500																												
			316 176 600 001	→	90	18.0	7.6	75	1350														300 072 300 113														
			316 363 600 001		120	21.0	8.7	75	1500																												
Renault Mégane Grandtourer	06/09-		316 289 600 001		90	20.5	7.7	75	1300	316 290 300 107					S	A	--	--	--	--	V	60	B														
			316 291 600 001		90	25.0	8.4	75	1500															316 290 300 113													
		KIT		316 289 900 113		90	22.5	7.7	75	1300	included in the KIT					S	A	--	--	D1	L1	V	60		B												
			KIT		316 291 900 113		90	27.0	8.4	75																1500											
		Renault Mégane Grandtourer	03/99-07/03		316 138 600 001	→	90	15.2	7.5	75														1350		300 072 300 113					--	FRE	--	--	D1	L1	V
Renault Mégane Grandtourer	07/03-06/09		316 208 600 001		90	21.5	7.7	75	1350	316 174 300 113																			S	FRE	--	--	D1	L1	H	45	L
			316 209 600 001		90	22.0	7.7	75	1350																												
		KIT		316 208 900 113		90	23.5	7.7	75	1350	included in the KIT					S	FRE	--	--	D1	L1	H	45	L													
			KIT		316 209 900 113		90	24.0	7.7	75															1350												

















Renault

Renault Mégane Saloon	07/03-		316 208 600 001	→	90	21.5	7.7	75	1350	300 072 300 107		--	FRE	--	--	--	--	V	B	
			316 209 600 001		90	22.0	7.7	75	1350	300 072 300 113		--	FRE	--	--	D1	L1	V	B	
Renault Mégane cc Convertible	04/10-		316 320 600 001		120	22.1	6.1	75	750	300 210 300 107		--	A	--	--	--	--	V	B	
									300 210 300 113	--		A	--	E1	D1	L1	V	90	B	
Renault Modus I exc. vehicles with factory provided bicycle carriers preparation.	10/04-01/08		316 216 600 001	→	60	16.0	5.8	75	900	300 065 300 005	for vehicles with earth switched rear fog lights please order separately	--	--	--	E1	--	--	H	15	B
								300 210 300 107	--	A		--	--	--	--	V	B			
							300 210 300 113	--	A	--		E1	D1	L1	V	90	B			
Renault Modus II exc. vehicles with rear end carrier system Velofix	01/08-		316 283 600 001		60	18.0	5.8	75	900	300 210 300 107		--	A	--	--	--	--	V	B	
			316 284 600 001			60	19.0	5.8	75	900		300 210 300 113	--	A	--	E1	D1	L1	V	90
Renault Scenic inc.Phase II from '99, exc.4 WD	01/97-06/03		316 113 600 001	→	90	16.3	8.0	75	1380	300 072 300 107	09/99- (Phase II)	--	FRE	--	--	--	--	V	B	
								300 072 300 113	-08/99 (Phase I)	--	FRE	--	--	D1	L1	V	B			
							316 113 300 113	→				09/99- (Phase II)	S	FRE	--	--	D1	L1	V	75















Renault Scenic inc. Grand Scenic, exc. Conquest	07/03-06/09		316 206 600 001	→ 	90	19.5	8.1	75	1350	316 207 300 113			S	FRE	--	E2	D1	H	45	B	
			316 352 600 001		120	18.0	8.7	75	1500												
			316 230 600 001	→ 	90	21.5	8.1	75	1350												
			316 207 600 001	→ 	90	20.0	8.1	75	1350												
			316 363 600 001		120	21.0	8.7	75	1500												
	KIT		316 206 900 113		90	21.0	8.1	75	1350	included in the KIT			S	FRE	--	E2	D1	H	45	B	
	KIT		316 207 900 113		90	22.0	8.1	75	1350												
Renault Scenic inc. Scenic Xmod	06/09-		316 352 600 001		120	18.0	8.7	75	1500	316 294 300 107			S	A	--	--	--	H	60	B	
			316 363 600 001		120	21.0	8.7	75	1500												316 294 300 113
		KIT		316 292 900 113		90	20.3	7.9	75	1300	included in the KIT			S	A	--	--	D1	L1	H	
	KIT		316 294 900 113		90	24.4	7.9	75	1300												
	Renault Traffic Van	05/01-09/14		314 364 600 001		60	21.0	12.3	85	2100	314 364 300 113	-08/06	S								
										314 860 300 107	→ 08/06-03/10	S	FRE	--	--	--	--	H	60	B	
										314 860 300 113	08/06-03/10	S	FRE	--	--	D1	L1	H	60	B	
										314 870 300 107	→ 03/10-	S	FRE	--	--	--	--	H	60	B	
										314 870 300 113	03/10-	S	FRE	--	--	D1	L1	H	60	B	



















Renault

Renault Traffic Van	08/06-03/10	KIT		314 364 900 113		60	23.0	12.3	85	2100		included in the KIT		08/06-03/10	S	FRE	--	--	D1	L1	H	60	B	
Renault Traffic Van	03/10-09/14	KIT		314 870 900 113		60	23.0	12.3	85	2100		included in the KIT		03/10-	S	FRE	--	--	D1	L1	H	60	B	
Renault Traffic Van	10/14-			316 311 600 001		60	20.0	12.1	80	2000		316 312 300 107			S	FRE	--	E2	--	--	H	90	B	
				316 312 600 001									316 312 300 113			S	FRE	--	E2	D1	L1	H	90	B
		KIT		316 311 900 113		60	22.0	12.1	80	2000			included in the KIT			S	FRE	--	E2	D1	L1	H	90	B
		KIT		316 312 900 113												S	FRE	--	E2	D1	L1	H	90	B
Renault Twingo	98-05/07			316 193 600 001			40	14.5	5.0	50	600		300 072 300 107			--	FRE	--	--	--	--	V		B
													300 072 300 113			--	FRE	--	--	D1	L1	V		B
Renault Twingo exc. model "Sport" inc. Gordini R.S. (a visible cutout is necessary)	06/07-14			316 326 600 001		60	17.0	4.2	65	500		300 210 300 107			--	A	--	--	--	--	--	V		B
													300 210 300 113			--	A	--	E1	D1	L1	V	90	B























Saab 9-3 Convertible	07/03-		324 023 600 001	→ 	120	12.0	9.0	75	1600	314 295 300 113	S	FRE	--	E	D	L1	H	30	B
					324 022 600 001	120	12.0	9.0	75										
Saab 9-3 Saloon	09/02-		324 023 600 001	→ 	120	12.0	9.0	75	1600	300 210 300 107	--	A	--	--	--	V			B
					324 022 600 001	120	12.0	9.0	75										
Saab 9-3 SportCombi exc. Aeto X WD, Turbo X	09/05-		324 023 600 001	→ 	120	12.0	9.0	75	1600	300 210 300 107	--	A	--	--	--	V			B
					324 022 600 001	120	12.0	9.0	75										
Saab 9-3 X SportCombi	11/09-		324 039 600 001	→ 	90	15.0	9.4	80	1600	300 210 300 107	--	A	--	--	--	V			B
					324 040 600 001	90	15.0	9.4	80										
Saab 9-5 Saloon and Estate	98-10		324 014 600 001	→	150	10.7	9.9	75	1800	300 210 300 113	--	A	--	E1	D1	L1	V	90	B
Saab 9-5 Saloon and Estate	08/10-		324 027 600 001		90	23.0	11.0	80	2000	314 386 300 107	S	CAN	--	E	--	V	90		B
					324 028 600 001	90	25.0	11.0	80										





Seat

Seat Alhambra Please order also bumper bracket (no. 321330616001).	96-05/00		321 329 600 001			120	17.0	12.2	85	2400	321 458 300 107			S	FRE	--	E1	--	--	H	60	B
																		S	FRE	--	E1	D1
Seat Alhambra thermal-insulation plate inc. inc. 4WD bumper bracket is not necessary	05/00-09/10		321 665 600 001			90	24.0	12.5	100	2500	321 458 300 107			S	FRE	--	E1	--	--	H	60	B
																		S	FRE	--	E1	D1
		KIT	321 665 900 113			90	26.0	12.5	100	2500	included in the KIT			S	FRE	--	E1	D1	L1	H	60	B
Seat Alhambra inc. 4WD 4-Motion: Please check the operating instructions of the vehicle before fitting the towbar.	05/00-09/10		321 775 600 001			90	26.0	12.5	100	2500	321 458 300 107			S	FRE	--	E1	--	--	H	60	B
																		S	FRE	--	E1	D1
		KIT	321 775 900 113			90	28.0	12.5	100	2500	included in the KIT			S	FRE	--	E1	D1	L1	H	60	B
Seat Alhambra	10/10-		321 698 600 001			22.0	12.3	100	2500		321 600 300 107			S	CAN	C	E	--	--	V	105	L
																	S	CAN	C	E	D	L1
		KIT	321 698 900 113			24.0	12.3	100	2500		included in the KIT			S	CAN	C	E	D	L1	V	105	L
Seat Alhambra Please order separately Spoiler and cover for bumper cutout at Seat dealer's.	10/10-		321 700 600 001			22.0	12.3	100	2500		321 600 300 107			S	CAN	C	E	--	--	V	105	L
																	S	CAN	C	E	D	L1
		KIT	321 700 900 113			24.0	12.3	100	2500		included in the KIT			S	CAN	C	E	D	L1	V	105	L
Seat Alhambra Please order separately Spoiler and cover for bumper cutout at Seat dealer's. for right-hand-drive vehicles	10/10-	KIT	321 700 900 153			24.0	12.3	100	2500		included in the KIT			S	CAN	C	E	D	L1	V	105	R
Seat Altea exc. FR	06/04-		344 043 600 001			60	18.0	9.3	100	1650	344 044 300 107			S	CAN	C	E	--	--	V	75	L
																	S	CAN	C	E	D	L1
		KIT	344 043 900 113			60	20.0	9.3	100	1650	included in the KIT			S	CAN	C	E	D	L1	V	90	L











Seat Altea inc. FR Please order separately cover for bumper cutout at Seat dealer's, no. 5P0 803 595.	06/04-			344 044 600 001		60	18.0	9.3	100	1650		344 044 300 107			S	CAN	C	E	--	--	V	75	L
												344 044 300 113			S	CAN	C	E	D	L1	V	90	L
		KIT		344 044 900 113		60	19.5	9.3	100	1650		included in the KIT			S	CAN	C	E	D	L1	V	90	L
Seat Altea XL + Freetrack	10/06-			344 043 600 001		60	18.0	9.3	100	1650		344 042 300 113	with preliminary setup	S	CAN	C	E	D	L1	H	45	B	
												344 044 300 107	without preliminary setup	S	CAN	C	E	--	--	V	75	L	
												344 044 300 113		S	CAN	C	E	D	L1	V	90	L	
												344 044 300 153		S	CAN	C	E	D	L1	V	90	R	
		KIT		344 043 900 113		60	20.0	9.3	100	1650		included in the KIT			S	CAN	C	E	D	L1	V	90	L
Seat Altea XL + Freetrack fitting cover for bumper cutout not available	10/06-			344 048 600 001		60	17.5	9.3	100	1650		344 042 300 113	with preliminary setup	S	CAN	C	E	D	L1	H	45	B	
												344 044 300 107	without preliminary setup	S	CAN	C	E	--	--	V	75	L	
												344 044 300 113		S	CAN	C	E	D	L1	V	90	L	
												344 044 300 153		S	CAN	C	E	D	L1	V	90	R	
		KIT		344 048 900 113		60	19.5	9.3	100	1650		included in the KIT			S	CAN	C	E	D	L1	V	90	L
Seat Cordoba Saloon all models, CLX/ GLX/ GTI and Coupé SX	01/96-12/02			344 025 600 001	→ 	90	17.0	6.7	70	1200		300 072 300 107			--	FRE	--	--	--	--	V		B
												300 072 300 113			--	FRE	--	--	D1	L1	V		B
Seat Cordoba Saloon	01/03-			344 040 600 001		90	20.0	7.0	50	1200		344 041 300 113	→	S	C2	C	E1	D1	L1	H	45	L	
Seat Cordoba Vario	07/97-03			344 025 600 001	→ 	90	17.0	6.7	70	1200		300 072 300 107			--	FRE	--	--	--	--	V		B
												300 072 300 113			--	FRE	--	--	D1	L1	V		B

Seat





















Seat Exeo Saloon and ST/ Estate	03/09-			344 073 600 001		120	19.0	10.6	100	2000		300 210 300 107			--	A	--	--	--	--	V		B
				344 074 600 001		120	20.0	10.6	100	2000		305 210 300 113			S	CAN	C	E	D1	L1	V	105	L
		KIT		344 053 900 113		120	21.0	10.6	100	2000		included in the KIT			S	CAN	C	E	D1	L1	V	105	L
				344 054 900 113		120	22.0	10.6	100	2000						S	CAN	C	E	D1	L1	V	105
Seat Ibiza exc. FR/Cupra	03/02-07/08			344 040 600 001		90	20.0	7.0	50	1200		344 040 300 107			S	C2	C	E1	--	--	H	45	B
												344 040 300 113			S	C2	C	E1	D1	--	H	45	B
Seat Ibiza ST Estate / 3/5 doors	07/08-			344 059 600 001		90	17.5	8.3	75	1400		317 420 300 107			S	CAN	C	E	--	--	V	105	L
												317 420 300 113			S	CAN	C	E	D1	L1	V	105	L
												317 420 300 153			S								
Seat Ibiza ST Estate / 3/5 doors Please order separately cover for bumper cutout at Seat dealer's.	07/08-			344 079 600 001		90	22.0	7.7	75	1400		317 420 300 107			S	CAN	C	E	--	--	V	105	L
												317 420 300 113			S	CAN	C	E	D1	L1	V	105	L
		KIT		344 060 900 113		90	24.0	7.7	75	1400		included in the KIT			S	CAN	C	E	D1	L1	V	105	L
Seat Inca	11/95-			321 437 600 001		90	15.0	6.7	50	1100		344 503 300 107			S	C2	--	E1	--	--	H	45	L
												344 503 300 113			S	C2	--	E1	D1	--	H	45	L
Seat Leon exc. FR + FRV Formula Race, exc. Cupra	09/05-			344 043 600 001		60	18.0	9.3	100	1650		321 600 300 107			S	CAN	C	E	--	--	V	105	L
												321 600 300 113			S	CAN	C	E	D	L1	V	105	L
												321 600 300 153			S	CAN	C	E	D	L1	V	105	R
Seat Leon inc. FR exc. FRV Formula Race, Cupra Please order separately cover for bumper cutout at Seat dealer' s, no. -05/09: 5P0 803 595, 05/09-: 1P0 092 595.	09/05-			344 044 600 001		60	18.0	9.3	100	1650		321 600 300 107			S	CAN	C	E	--	--	V	105	L
												321 600 300 113			S	CAN	C	E	D	L1	V	105	L
												321 600 300 153			S	CAN	C	E	D	L1	V	105	R

Seat Leon inc. FR exc. FRV Formula Race, Cupra Please order separately cover for bumper cutout at Seat dealer's, no. -05/09: 5P0 803 595, 05/09-: 1P0 092 595. for right-hand-drive vehicles	09/05-10/12	KIT		344 044 900 153		60	20.0	9.3	100	1650		included in the KIT		S	CAN	C	E	D	L1	V	105	R
Seat Leon 5 doors Seat Leon SC, 3 doors Seat Leon ST, Combi Please order separately cover for bumper cutout at Skoda dealer's.	11/12-			317 132 600 001		60	19.0	10.3	80	2000		305 403 300 107	-06/14 with preliminary setup	S	CAN	C	E	--	--	H	45	B
												305 403 300 113	-06/14 with preliminary setup	S	CAN	C	E	--	--	H	45	B
												305 406 300 107	-06/14 without preliminary setup	S	CAN	C	E	--	--	V	150	B
												305 406 300 113	-06/14 without preliminary setup	S	CAN	C	E	D	L1	V	150	B
												305 407 300 107	06/14- with preliminary setup	S	CAN	C	E	--	--	H		B
												305 407 300 113	06/14- with preliminary setup	S	CAN	C	E	D	L	H		B
												305 408 300 107	06/14- without preliminary setup	S	CAN	C	E	--	--	V		B
												305 408 300 113	06/14- without preliminary setup	S	CAN	C	E	D	L	V		B





















Seat























Seat Leon 5 doors Seat Leon SC, 3 doors Seat Leon ST, Combi	11/12-		317 131 600 001		60	19.0	10.3	80	2000		305 403 300 107	-06/14 with preliminary setup	S	CAN	C	E	--	--	H	45	B
											305 403 300 113	-06/14 with preliminary setup	S	CAN	C	E	--	--	H	45	B
											305 406 300 107	-06/14 without preliminary setup	S	CAN	C	E	--	--	V	150	B
											305 407 300 107	06/14- with preliminary setup	S	CAN	C	E	--	--	H		B
											305 407 300 113	06/14- with preliminary setup	S	CAN	C	E	D	L	H		B
											305 408 300 107	06/14- without preliminary setup	S	CAN	C	E	--	--	V		B
											305 408 300 113	06/14- without preliminary setup	S	CAN	C	E	D	L	V		B
Seat Leon 5 doors Seat Leon SC, 3 doors Seat Leon ST, Combi	11/12-06/14	KIT 	317 131 900 113		60	21.0	10.3	85	2000		included in the KIT	-06/14 without preliminary setup	S	CAN	C	E	D	L1	V	150	B
Seat Leon 5 doors Seat Leon SC, 3 doors Seat Leon ST, Combi Please order separately cover for bumper cutout at Skoda dealer's.	11/12-06/14	KIT 	317 132 900 113		60	21.0	10.3	80	2000		included in the KIT	-06/14 without preliminary setup	S	CAN	C	E	D	L1	V	150	B
Seat Leon 5 doors Seat Leon SC, 3 doors Seat Leon ST, Combi	06/14-	KIT 	305 408 900 113		60	19.0	10.3	85	2000		included in the KIT	06/14- without preliminary setup	S	CAN	C	E	D	L	V		B
Seat Leon 5 doors Seat Leon SC, 3 doors Seat Leon ST, Combi Please order separately cover for bumper cutout at Skoda dealer's.	06/14-	KIT 	305 409 900 113		60	21.0	10.3	85	2000		included in the KIT	06/14- without preliminary setup	S	CAN	C	E	D	L	V		B
Seat Mii This towbar can only be used in combination with load carriers/ cycle carriers! This vehicle is not homologated for towing trailers.	11-		350 044 600 001			15.0		50			321 044 300 113		S	CAN	E	--	--	V	120	B	





















Seat Toledo type 1M form veh.ident no. ...8950	04/99-11/04		344 023 600 001			90	16.6	8.6	75	1600		300 073 300 113			--	FRE	--	--	D1	L1	V	90	B	
Seat Toledo type 6L, 5P, 1P	11/04-03/12		344 043 600 001			60	18.0	9.3	100	1650		344 044 300 107			S	CAN	C	E	--	--	V	75	L	
			344 044 600 001			60	18.0	9.3	100	1650		344 044 300 113			S	CAN	C	E	D	L1	V	90	L	
			344 044 600 001			60	18.0	9.3	100	1650		344 044 300 153			S	CAN	C	E	D	L1	V	90	R	
		KIT		344 043 900 113			60	20.0	9.3	100	1650		included in the KIT			S	CAN	C	E	D	L1	V	90	L
		KIT		344 044 900 113			60	19.5	9.3	100	1650					S	CAN	C	E	D	L1	V	90	L
Seat Toledo	03/12-		317 129 600 001			45	21.5	8.5	50	1200		317 420 300 107			S	CAN	C	E	--	--	V	105	L	
			317 130 600 001			45	21.5	8.5	50	1200		317 420 300 113			S	CAN	C	E	D1	L1	V	105	L	
			317 130 600 001			45	21.5	8.5	50	1200		317 420 300 153			S									R
		KIT		317 129 900 113			45	23.0	8.5	50	1200		included in the KIT			S	CAN	C	E	D1	L1	V	105	L
		KIT		317 130 900 113			45	23.0	8.5	50	1200					S	CAN	C	E	D1	L1	V	105	L
Seat Toledo for right-hand-drive vehicles	03/13-	KIT		317 106 900 153			45	23.0	8.5	50	1200		included in the KIT			S								R
		KIT		317 107 900 153			45	24.0	8.5		1200					S								

Skoda Fabia II Estate exc. RS Please order cover for bumper cutout at Skoda dealers.	01/08-12/14			317 086 600 001		40	14.5	7.2	86	1200		317 400 300 113	-05/10	S	C2	C	E	D1	--	H	45	B
												317 420 300 113	05/10-	S	CAN	C	E	D1	L1	V	105	L
												317 420 300 153	05/10-	S								R
Skoda Fabia II Estate exc. RS	05/10-12/14	KIT		317 250 900 113		40	16.5	7.2	86	1200		included in the KIT	05/10-	S	CAN	C	E	D1	L1	V	105	L
Skoda Fabia II Estate exc. RS Please order cover for bumper cutout at Skoda dealers.	05/10-12/14	KIT		317 251 900 113		40	16.5	7.2	86	1200		included in the KIT	05/10-	S	CAN	C	E	D1	L1	V	105	L
Skoda Fabia II Estate exc. RS & VRS (VRS is not homologated to tow.) for right-hand-drive vehicles	05/10-12/14	KIT		317 250 900 153		40	16.5	7.2	86	1200		included in the KIT	05/10-	S								R
Skoda Fabia II Hatchback exc. RS + Monte Carlo	06/07-05/10	KIT		317 085 900 113		40	16.5	7.2	86	1200		included in the KIT	-05/10	S	C2	C	E	D1	--	H	45	B
Skoda Fabia II Hatchback exc. RS + Monte Carlo Please order cover for bumper cutout at Skoda dealers.	06/07-05/10	KIT		317 086 900 113		40	16.5	7.2	86	1200		included in the KIT	-05/10	S	C2	C	E	D1	--	H	45	B
Skoda Fabia II Hatchback exc. RS + Monte Carlo	06/07-10/14			317 085 600 001		40	14.5	7.2	86	1200		317 400 300 107	-05/10	S	C2	C	E	--	--	H	45	B
												317 400 300 113	-05/10	S	C2	C	E	D1	--	H	45	B
												317 420 300 107	05/10-	S	CAN	C	E	--	--	V	105	L
												317 420 300 113	05/10-	S	CAN	C	E	D1	L1	V	105	L
												317 420 300 153	05/10-	S								R
												344 250 300 153	05/10-	S	CAN	C	E	D	L1	V	90	R
Skoda Fabia II Hatchback exc. RS Please order cover for bumper cutout at Skoda dealers.	06/07-10/14			317 086 600 001		40	14.5	7.2	86	1200		317 400 300 113	-05/10	S	C2	C	E	D1	--	H	45	B
												317 420 300 113	05/10-	S	CAN	C	E	D1	L1	V	105	L
												317 420 300 153	05/10-	S								R
												344 250 300 153	05/10-	S	CAN	C	E	D	L1	V	90	R
Skoda Fabia II Hatchback exc. RS + Monte Carlo	05/10-10/14	KIT		317 250 900 113		40	16.5	7.2	86	1200		included in the KIT	05/10-	S	CAN	C	E	D1	L1	V	105	L
Skoda Fabia II Hatchback exc. RS + Monte Carlo Please order cover for bumper cutout at Skoda dealers.	05/10-10/14	KIT		317 251 900 113		40	16.5	7.2	86	1200		included in the KIT	05/10-	S	CAN	C	E	D1	L1	V	105	L





















Skoda

























Skoda Fabia II Hatchback exc. RS & VRS (VRS is not homologated to tow.) for right-hand-drive vehicles	05/10-10/14	KIT		317 250 900 153		40	16.5	7.2	86	1200	included in the KIT	S								R	
		KIT		317 251 900 153		40	16.5	7.2	86	1200											
Skoda Fabia III Estate	01/15-			317 113 600 001							317 114 300 107	S	CAN	C	E	--	--	V		L	
				317 114 600 001								317 114 300 113	S	CAN	C	E	D1	L1	V		L
		KIT		317 113 900 113								included in the KIT	S	CAN	C	E	D1	L1	V		L
		KIT		317 114 900 113																	
Skoda Fabia III Hatchback	11/14-			317 113 600 001							317 114 300 107	S	CAN	C	E	--	--	V		L	
				317 114 600 001								317 114 300 113	S	CAN	C	E	D1	L1	V		L
		KIT		317 113 900 113								included in the KIT	S	CAN	C	E	D1	L1	V		L
		KIT		317 114 900 113																	
Skoda Octavia I Saloon/Estate type 1U exc. 4 WD, inc. RS Note: For towing capacities of 1400 kg and more please check the operating instructions of your car.	12/96-01/05			317 015 600 001		90	15.0	8.4	60	1500	317 015 300 107	S	FRE	--	E	--	--	H	45	B	
				317 016 600 001		90	16.2	8.4	60	1500	317 015 300 113	S	FRE	--	E	D1	L1	H	45	B	
		KIT		317 015 900 113		90	17.0	8.4	60	1500	included in the KIT	S	FRE	--	E	D1	L1	H	45		B
		KIT		317 016 900 113		90	18.2	8.4	60	1500											

Skoda Octavia I Saloon/Estate 4x4 Note: For towing capacities of 1400 kg and more please check the operating instructions of your car.	09/99-		317 037 600 001			90	15.6	9.2	75	1650		317 015 300 107			S	FRE	--	E	--	--	H	45	B								
Skoda Octavia II Estate 1Z / 3T inc. 4 x 4, RS and Scout Facelift 11/08-: cutout is not necessary	01/05-		317 104 600 001			40	18.0	10.6	100	2000		321 600 300 107			S	CAN	C	E	--	--	V	105	L								
		KIT		317 102 600 001			40	19.0	10.6	100	2000		321 600 300 153			S	CAN	C	E	D	L1	V	105	R							
KIT		317 104 900 113			40	20.0	10.6	100	2000		included in the KIT			S	CAN	C	E	D	L1	V	105	L									
KIT		317 102 900 113			40	21.0	10.6	100	2000		included in the KIT			S	CAN	C	E	D	L1	V	105	L									
Skoda Octavia II Estate 1Z / 3T inc. 4 x 4, RS and Scout Facelift 11/08-: cutout is not necessary for right-hand-drive vehicles	01/05-01/13	KIT		317 102 900 153			40	21.0	10.6	100	2000				S	CAN	C	E	D	L1	V	105	R								
Skoda Octavia II Saloon 1Z / 3T inc. 4 x 4, RS and Scout Facelift 11/08-: cutout is not necessary	01/05-		317 104 600 001			40	18.0	10.6	100	2000		321 600 300 107			S	CAN	C	E	--	--	V	105	L								
		KIT		317 102 600 001			40	19.0	10.6	100	2000		321 600 300 153			S	CAN	C	E	D	L1	V	105	R							
KIT		317 104 900 113			40	20.0	10.6	100	2000		included in the KIT			S	CAN	C	E	D	L1	V	105	L									
KIT		317 102 900 113			40	21.0	10.6	100	2000		included in the KIT			S	CAN	C	E	D	L1	V	105	L									
Skoda Octavia II Saloon 1Z / 3T inc. 4 x 4, RS and Scout Facelift 11/08-: cutout is not necessary for right-hand-drive vehicles	01/05-01/13	KIT		317 102 900 153			40	21.0	10.6	100	2000				S	CAN	C	E	D	L1	V	105	R								

Skoda Rapid / Rapid Spaceback	10/12-			317 129 600 001		45	21.5	8.5	50	1200		317 420 300 107			S	CAN	C	E	--	--	V	105	L
				317 130 600 001		45	21.5	8.5	50	1200		317 420 300 113			S	CAN	C	E	D1	L1	V	105	L
												317 420 300 153			S								R
	KIT		317 129 900 113		45	23.0	8.5	50	1200						S	CAN	C	E	D1	L1	V	105	L
		KIT		317 130 900 113		45	23.0	8.5	50	1200		included in the KIT			S	CAN	C	E	D1	L1	V	105	L
Skoda Rapid / Rapid Spaceback for right-hand-drive vehicles	10/12-	KIT		317 129 900 153		45	23.0	8.5	50	1200					S								R
			KIT		317 130 900 153		45	23.0	8.5	50	1200		included in the KIT			S							
Skoda Roomster inc. Skoda Praktik 07- inc. Scout	09/06-			317 063 600 001		40	17.0	7.5	50	1200		317 400 300 107	-05/10	S	C2	C	E	--	--	H	45	B	
											317 400 300 113	-05/10	S	C2	C	E	D1	--	H	45	B		
											317 420 300 107	05/10-	S	CAN	C	E	--	--	V	105	L		
											317 420 300 113	05/10-	S	CAN	C	E	D1	L1	V	105	L		
											317 420 300 153	05/10-	S									R	
Skoda Roomster inc. Skoda Praktik 07- inc. Scout Please order cover for bumper cutout at Skoda-dealers, order-no. XEA 77001.	09/06-			317 064 600 001		40	17.0	7.5	50	1200		317 400 300 107	-05/10	S	C2	C	E	--	--	H	45	B	
											317 400 300 113	-05/10	S	C2	C	E	D1	--	H	45	B		
											317 420 300 107	05/10-	S	CAN	C	E	--	--	V	105	L		
											317 420 300 113	05/10-	S	CAN	C	E	D1	L1	V	105	L		
											317 420 300 153	05/10-	S									R	
Skoda Roomster inc. Skoda Praktik 07- inc. Scout	09/06-05/10	KIT		317 063 900 113		40	19.0	7.5	50	1200		included in the KIT	-05/10	S	C2	C	E	D1	--	H	45	B	
Skoda Roomster inc. Skoda Praktik 07- inc. Scout Please order cover for bumper cutout at Skoda-dealers, order-no. XEA 77001.	09/06-05/10	KIT		317 064 900 113		40	19.0	7.5	50	1200		included in the KIT	-05/10	S	C2	C	E	D1	--	H	45	B	









Skoda

Skoda Roomster inc. Skoda Praktik 07- inc. Scout	05/10-	KIT		317 420 900 113		40	19.0	7.5	50	1200		included in the KIT		05/10-	S	CAN	C	E	D1	L1	V	105	L	
Skoda Roomster inc. Skoda Praktik 07- inc. Scout for right-hand-drive vehicles	05/10-	KIT		317 420 900 153		40	19.0	7.5	50	1200		included in the KIT		05/10-	S									R
Skoda Roomster inc. Skoda Praktik 07- inc. Scout Please order cover for bumper cutout at Skoda-dealers, order-no. XEA 77001.	05/10-	KIT		317 421 900 113		40	19.0	7.5	50	1200		included in the KIT		05/10-	S	CAN	C	E	D1	L1	V	105	L	
Skoda Roomster inc. Skoda Praktik 07- inc. Scout Please order cover for bumper cutout at Skoda-dealers, order-no. XEA 77001. for right-hand-drive vehicles	05/10-	KIT		317 421 900 153		40	19.0	7.5	50	1200		included in the KIT		05/10-	S									R
Skoda Superb exc. vehicles with tuning set by M +S	03/02-06/08		 	321 874 600 001 321 505 600 001		120 90	17.0 20.8	10.5 10.3	85 85	2000 1800		317 050 300 113			S	FRE	--	E	D	L1	V	90	B	
Skoda Superb Estate inc. facelift 2013 for right-hand-drive vehicles	12/09-	KIT		317 102 900 153		40	21.0	10.6	100	2000		included in the KIT			S	CAN	C	E	D	L1	V	105	R	
Skoda Superb Estate facelift from 06/13-	12/09-05/15		 	317 104 600 001 317 102 600 001		40	18.0	10.6	100	2000		321 600 300 107 321 600 300 113 321 600 300 153			S	CAN	C	E	--	--	V	105	L	
		KIT		317 104 900 113		40	20.0	10.6	100	2000		included in the KIT			S	CAN	C	E	D	L1	V	105	L	
		KIT		317 102 900 113		40	21.0	10.6	100	2000		included in the KIT			S	CAN	C	E	D	L1	V	105	L	





















Skoda Superb Saloon inc. facelift 2013 for right-hand-drive vehicles	06/08-	KIT		317 102 900 153		40	21.0	10.6	100	2000		included in the KIT				S	CAN	C	E	D	L1	V	105	R		
Skoda Superb Saloon facelift from 06/13-	06/08-05/15			317 104 600 001		40	18.0	10.6	100	2000		321 600 300 107				S	CAN	C	E	--	--	V	105	L		
				317 102 600 001		40	19.0	10.6	100	2000		321 600 300 113					S	CAN	C	E	D	L1	V	105	L	
				317 104 900 113		40	20.0	10.6	100	2000		included in the KIT					S	CAN	C	E	D	L1	V	105	L	
				317 102 900 113		40	21.0	10.6	100	2000								S	CAN	C	E	D	L1	V	105	L
Skoda Yeti	08/09-			317 125 600 001		40	18.0	10.6	85	2100		317 079 300 107				S	CAN	C	E	--	--	V	105	L		
				317 080 900 113		40	20.0	10.6	85	2100		317 079 300 113					S	CAN	C	E	D	L1	V	105	L	
Skoda Yeti For the cutout in the bumper a special tool is necessary. We would therefore recommend to let the cutout be made at Skoda dealers. Please order cover and frame for bumper cutout at Skoda dealers.	08/09-			317 117 600 001	→ 	40	19.5	10.6	85	2100		317 079 300 107				S	CAN	C	E	--	--	V	105	L		
				317 128 600 001		40	19.5	10.6	85	2100		317 079 300 113					S	CAN	C	E	D	L1	V	105	L	
				317 105 900 113		40	20.5	10.6	85	2100		317 079 300 153					S	CAN	C	E	D	L1	V	120	R	
Skoda Yeti for right-hand-drive vehicles	08/09-	KIT		317 080 900 143		40	20.0	10.6	85	2100		included in the KIT				S	CAN	C	E	D	L1	V	120	R		
		KIT		317 117 900 143		40	19.5	10.6	85	2100		included in the KIT					S	CAN	C	E	D	L1	V	120	R	





























Smart

Smart ForFour	05/04-		313 234 600 001	→	>150	20.0	5.3	50	800	300 072 300 113				--	FRE	--	--	D1	L1	V		B
---------------	--------	---	-----------------	---	------	------	-----	----	-----	-----------------	--	--	--	----	-----	----	----	----	----	---	--	---

Ssang Yong Korando C exc. Pickup	10/10-			349 038 600 001	→		60	21.0	11.6	100	2400		349 039 300 113	→	-11/13	S	A	--	E	D1	L1	V	B
				349 039 600 001	→		60	22.0	11.6	100	2400												
Ssang Yong Korando C exc. Pickup	10/10-11/13	KIT		349 038 900 113	→		60	23.0	11.5	100	2400		included in the KIT	→	-11/13	S	A	--	E	D1	L1	V	B
				349 039 900 113	→		60	24.0	11.5	100	2400												
Ssang Yong Kyron exc. vehicles with park distance control	11/05-			349 026 600 001	→		90	29.0	11.9	100	2300		300 061 300 107			--	C2	--	E1	--	--	V	B
													300 061 300 113			--	C2	--	--	--	V	B	
Ssang Yong Kyron	11/05-			349 027 600 001	→		90	29.0	11.9	100	2300		300 061 300 107			--	C2	--	E1	--	--	V	B
													300 061 300 113			--	C2	--	--	--	V	B	
Ssang Yong Rexton towball 329076600001 inc.	02-03/13			349 028 600 001	→		90	22.0	14.5	140	3500		300 061 300 107			--	C2	--	E1	--	--	V	B
													300 061 300 113			--	C2	--	--	--	V	B	





Subaru



















Subaru Forester	10/97-03/08		348 013 600 001		60	20.9	10.0	85	1950	300 061 300 107	--	C2	--	E1	--	--	V	B	
											300 061 300 113	--	C2	--	--	--	V	B	
Subaru Forester SH	03/08-	 	348 023 600 001		90	25.0	9.9	80	2000	348 023 300 113	S	C2	--	E1	D1	L1	V	40	B
			348 024 600 001		90	25.0	9.9	80	2000										
Subaru Forester SJ	03/13-	 	348 038 600 001		90	23.0	10.4	90	2150	348 037 300 113	S	A	--	--	D	L1	V	90	B
			348 039 600 001		90	25.0	10.4	90	2150										
		KIT	348 038 900 113		90	26.0	10.4	90	2150	included in the KIT	S	A	--	--	D	L1	V	90	B
			KIT		348 039 900 113	90	27.0	10.4	90		2150								
Subaru Impreza exc. WRX	10/00-09/07		348 031 600 001		120	23.0	8.6	80	1600	300 061 300 107	--	C2	--	E1	--	--	V	B	
										300 061 300 113	--	C2	--	--	--	V	B		
Subaru Impreza exc. WRX/Sti	01/13-	 	348 036 600 001		90	22.0	8.4	75	1500	348 037 300 113	S	A	--	--	D	L1	V	90	B
			KIT		348 036 900 113	90	23.0	8.4	75		1500	included in the KIT	S	A	--	--	D	L1	V
Subaru Impreza Hatchback inc. WRX, XV 09/10-10/11	09/07-13	 	348 019 600 001		90	29.0	8.6	75	1600	300 210 300 113	--	A	--	E1	D1	L1	V	90	B
			348 020 600 001		90	29.0	8.6	75	1600	348 020 300 113	→	S	C2	--	E1	D1	L1	V	40
Subaru Impreza Saloon exc. WRX/Sti inc. XV 09/10-10/11	09/07-13	 	348 019 600 001		90	29.0	8.6	75	1600	300 210 300 107	--	A	--	--	--	--	V	B	
			348 020 600 001		90	29.0	8.6	75	1600	300 210 300 113	--	A	--	E1	D1	L1	V	90	B















Subaru Justy G3X	09/03-10/07		348 032 600 001			120	24.0	6.1	70	1000		300 072 300 107			--	FRE	--	--	--	--	V		B
																			--	FRE	--	--	D1
Subaru Legacy Estate type BD/BF/BG/BH exc. Outback	04/94-09/03		348 010 600 001			90	19.2	9.6	80	1900		300 061 300 107			--	C2	--	E1	--	--	V		B
																		--	C2	--	--	--	--
Subaru Legacy Estate exc. Outback	09/03-09/09		348 015 600 001			120	20.0	10.1	85	2060		300 072 300 107			--	FRE	--	--	--	--	V		B
																		--	FRE	--	--	D1	L1
Subaru Legacy Estate	09/09-		348 025 600 001			90	23.0	9.8	80	1800		300 210 300 113			--	A	--	E1	D1	L1	V	90	B
							348 026 600 001			90	24.0		9.8	80	1800								
Subaru Legacy Estate	09/09-		348 021 600 001	→		90	23.0	9.8	80	1800		300 210 300 113			--	A	--	E1	D1	L1	V	90	B
							348 022 600 001	→		90	24.0		9.8	80	1800								
Subaru Legacy Outback	09/03-09/09		348 034 600 001	→		90	21.0	10.1	85	2000		300 072 300 107			--	FRE	--	--	--	--	V		B
																		--	FRE	--	--	D1	L1
Subaru Legacy Outback facelift from 05/13-	09/09-		348 027 600 001			120	23.0	10.4	80	2000		300 210 300 113			--	A	--	E1	D1	L1	V	90	B
							348 028 600 001			120	26.0		10.4	80	2000								
Subaru Outback	03/15-		348 062 600 001			60	23.0	10.5	90	2000													
							348 063 600 001			60	25.0	10.5	90	2000									
Subaru Trezia	03/11-		335 413 600 001			60	17.5	5.8	50	900		335 413 300 107			S	FRE	--	--	--	--	V	105	B
							335 414 600 001			60	17.5	5.8	50	900		335 413 300 113			S	FRE	--	--	D1

Subaru





















Subaru























Subaru XV	03/12-			348 037 600 001		90	20.0	8.9	75	1600		348 037 300 113			S	A	--	--	D	L1	V	90	B
		KIT		348 037 900 113		90	22.0	8.9	75	1600		included in the KIT			S	A	--	--	D	L1	V	90	B

Suzuki Alto	09-		332 306 600 001		90	15.0	4.2	50	650	332 306 300 113		S	FRE	--	--	D1	--	H	60	L
		KIT		332 306 900 113		90	17.0	4.2	50	650	included in the KIT		S	FRE	--	--	D1	--	H	60
Suzuki Grand Vitara 3 + 5 doors + XL7 (FT/GT/HT)	98-09/05		342 172 600 001		60	19.0	10.4	80	1850	300 065 300 005	for vehicles with earth switched rear fog lights please order separately	--	--	--	E1	--	--	H	15	B
										300 072 300 107		--	FRE	--	--	--	--	V		B
											300 072 300 113		--	FRE	--	--	D1	L1	V	
Suzuki Grand Vitara 3 doors JT for vehicles with spare wheel on tailgate	10/05-		342 098 600 001		90	20.0	8.7	100	1600	342 099 300 113		S	FRE	--	E	D1	L1	H	60	B
Suzuki Grand Vitara 3 doors JT exc. vehicles with spare wheel on the tailgate	08/10-		341 022 600 001		90	23.0	8.9	75	1650	342 099 300 113		S	FRE	--	E	D1	L1	H	60	B
Suzuki Grand Vitara 5 doors JT for vehicles with spare wheel on tailgate	04/05-		342 162 600 001		90	26.0	10.6	80	2000	342 099 300 113		S	FRE	--	E	D1	L1	H	60	B
Suzuki Grand Vitara 5 doors JT exc. vehicles with spare wheel on the tailgate	08/10-		341 020 600 001		90	23.0	10.8	85	2000	342 099 300 113		S	FRE	--	E	D1	L1	H	60	B
			341 021 600 001		90	26.0	10.8	85	2000											
Suzuki Ignis 2x4 JSA (Japanese produced) inc. 4x4	00-03		342 161 600 001		120	20.0	6.0		1000	300 072 300 107		--	FRE	--	--	--	--	V		B
												--	FRE	--	--	D1	L1	V		B
Suzuki Ignis SUV TSM (European produced) exc. Ignis Sport	03-		348 032 600 001		120	24.0	6.1	70	1000	300 072 300 107		--	FRE	--	--	--	--	V		B
												--	FRE	--	--	D1	L1	V		B
Suzuki Jimny	98-		341 003 600 001		60	26.0	7.0	75	1300	300 072 300 107		--	FRE	--	--	--	--	V		B
												--	FRE	--	--	D1	L1	V		B













Suzuki Splash only for 1,2 l gas engine	08-			314 308 600 001		90	16.0	4.2	50	600		332 306 300 113			S	FRE	--	--	D1	--	H	60	L
				314 309 600 001		90	16.0	4.2	50	600													
		KIT KIT		314 308 900 113		90	18.0	4.2	50	600		included in the KIT			S	FRE	--	--	D1	--	H	60	L
				314 309 900 113		90	18.0	4.2	50	600													
Suzuki Swift exc. 4 WD exc. Sport	09/05-10/10			341 006 600 001	→ 	90	14.0	6.0	60	1000		342 099 300 113			S	FRE	--	E	D1	L1	H	60	B
Suzuki Swift 2 + 4 WD exc. Sport not in combination with X-ITE spoiler kit	10/10-			341 016 600 001		90	21.0	6.2	60	1000		300 210 300 113	→		--	A	--	E1	D1	L1	V	90	B
												341 016 300 113											
Suzuki Swift 4x4	05-07/07			342 163 600 001	→ 	120	24.0	6.5	60	1100		342 099 300 113			S	FRE	--	E	D1	L1	H	60	B
Suzuki Vitara	03/15-			341 043 600 001																			





















Toyota

Toyota Auris 3/5 doors	03/07-13			335 412 600 001			60	21.5	8.6	60	1500		335 025 300 113		additional cable for continuous plus (Please order additionally.)	--	--	--	E1	D	L	V	75	L	
				335 353 600 001			75	21.6	8.6	60	1500		335 600 300 113			S	FRE	--	--	D1	L1	H	60	L	
	KIT			335 333 600 001			60	22.5	8.6	60	1500		335 025 300 113		additional cable for continuous plus (Please order additionally.)	--	--	--	E1	D	L	V	75	L	
		KIT			335 334 600 001			75	22.6	8.6	60	1500		included in the KIT			S	FRE	--	--	D1	L1	H	60	L
Toyota Auris Hatchback	01/13-			335 423 600 001			90	23.0	8.7	75	1500		335 423 300 107			S	FRE	--	E2	--	--	V	120	B	
				335 423 300 113			90	24.0	8.7	75	1500		included in the KIT			S	FRE	--	E2	D	L1	V	120	B	
Toyota Auris Touring Sports	07/13-			335 424 600 001			90	15.0	8.7	75	1500		335 423 300 107			S	FRE	--	E2	--	--	V	120	B	
				335 425 600 001			90	17.0	8.7	75	1500		335 423 300 113			S	FRE	--	E2	D	L1	V	120	B	
		KIT			335 424 900 113			90	17.0	8.7	75	1500		included in the KIT			S	FRE	--	E2	D	L1	V	120	B
		KIT			335 425 900 113			90	19.0	8.7	75	1500					S	FRE	--	E2	D	L1	V	120	B
Toyota Avensis Saloon, 4 doors T22	12/97-04/03			335 219 600 001	 		60	15.3	8.3	75	1550		300 072 300 107			--	FRE	--	--	--	--	V		B	
													300 072 300 113			--	FRE	--	--	D1	L1	V		B	













Toyota Avensis Saloon, 4 doors T27	02/09-			335 343 600 001		60	24.0	10.3	80	2000		335 345 300 113				S	FRE	--	--	D	L1	V	105	B	
				335 344 600 001		60	24.0	10.3	80	2000															
		KIT		335 343 900 113		60	26.0	10.3	80	2000															included in the KIT
		KIT		335 344 900 113		60	26.0	10.3	80	2000															
Toyota Avensis Hatchback, 5 doors T25	04/03-01/09			335 301 600 001		90	24.5	8.6	75	1550		335 025 300 113		additional cable for continuous plus (Please order additionally.)	--	--	--	E1	D	L	V	75	L		
				335 302 600 001	→	90	27.0	8.6	75	1550		335 303 300 113			S	FRE	--	--	D1	L1	H	45	L		
		KIT		335 310 600 001	→	90	25.5	8.6	75	1550		335 025 300 113		additional cable for continuous plus (Please order additionally.)	--	--	--	E1	D	L	V	75	L		
		KIT		335 311 600 001	→	90	28.0	8.6	75	1550		included in the KIT			S	FRE	--	--	D1	L1	H	45	L		
Toyota Avensis Hatchback, 5 doors T27	01/09-			335 343 600 001		60	24.0	10.3	80	2000		335 345 300 113				S	FRE	--	--	D	L1	V	105	B	
				335 344 600 001		60	24.0	10.3	80	2000															
		KIT		335 343 900 113		60	26.0	10.3	80	2000															included in the KIT
		KIT		335 344 900 113		60	26.0	10.3	80	2000															
Toyota Avensis Saloon T25	04/03-01/09			335 301 600 001		90	24.5	8.6	75	1550		335 025 300 113		additional cable for continuous plus (Please order additionally.)	--	--	--	E1	D	L	V	75	L		
				335 302 600 001	→	90	27.0	8.6	75	1550		335 302 300 113			S	FRE	--	--	D1	L1	H	45	B		















Toyota

Toyota Avensis Estate T22	12/97-04/03		335 223 600 001	→ 	60	15.6	8.3	75	1550		300 072 300 107									--	FRE	--	--	--	--	V		B		
											300 072 300 113									--	FRE	--	--	D1	L1	V		B		
Toyota Avensis Estate T25 inc. models 07/06-	04/03-01/09		335 303 600 001		100	22.0	8.6	75	1550		335 025 300 113		additional cable for continuous plus (Please order additionally.)								--	--	--	E1	D	L	V	75	L	
											335 304 600 001										100	24.0	8.6	75	1550	335 304 300 113	S	FRE	--	--
Toyota Avensis Estate T25	04/03-01/09	KIT 	335 308 600 001		100	23.0	8.6	75	1550		335 025 300 113		additional cable for continuous plus (Please order additionally.)								--	--	--	E1	D	L	V	75	L	
											335 309 600 001										100	25.0	8.6	75	1550	included in the KIT	S	FRE	--	--
Toyota Avensis Estate T27	01/09-		335 345 600 001		60	24.0	10.3	80	2000		335 345 300 113										S	FRE	--	--	D	L1	V	105	B	
																					KIT 	335 345 900 113		60	26.0	10.3	80	2000		included in the KIT
		KIT 	335 346 900 113		60	26.0	10.3	80	2000																					
Toyota Corolla Estate E12	01/02-		335 288 600 001		70	16.6	7.9	55	1300		300 072 300 113										--	FRE	--	--	D1	L1	V		B	
Toyota Corolla Liftback E11 (5 door)	07/97-12/01		335 211 600 001	→	60	15.4	7.4	75	1400		300 072 300 107										--	FRE	--	--	--	V		B		
											300 072 300 113										--	FRE	--	--	D1	L1	V		B	
Toyota Corolla Liftback E12 3/5 doors	01/02-		335 284 600 001		60	15.5	7.9	55	1300		300 072 300 107										--	FRE	--	--	--	V		B		
											335 285 600 001										→ 	90	17.0	7.9	55	1300	300 072 300 113	--	FRE	--
Toyota Corolla Saloon E11	07/97-07/02		335 211 600 001	→	60	15.4	7.4	75	1400		300 072 300 107										--	FRE	--	--	--	V		B		
											300 072 300 113										--	FRE	--	--	D1	L1	V		B	



















Toyota Corolla Saloon E12	07/02-08/07		335 286 600 001	→ 	70	17.6	7.9	55	1300	300 072 300 107			--	FRE	--	--	--	--	V		B	
												300 072 300 113			--	FRE	--	--	D1	L1	V	
Toyota Corolla Saloon	08/07-13		335 343 600 001		60	24.0	10.3	80	2000	300 072 300 107			--	FRE	--	--	--	--	V		B	
					335 344 600 001		60	24.0	10.3	80	2000	300 072 300 113			--	FRE	--	--	D1	L1	V	
Toyota Corolla Verso	04/04-09		335 322 600 001		70		8.6	75	1450	335 025 300 113	additional cable for continuous plus (Please order additionally.)		--	--	--	E1	D	L	V	75	L	
					335 323 600 001		70		8.6	75		1450	335 323 300 113	S	FRE	--	--	D1	L1	H	45	L
		KIT		335 322 900 113		70		8.6	75	1450	335 025 300 113	additional cable for continuous plus (Please order additionally.)		--	--	--	E1	D	L	V	75	L
		KIT		335 323 900 113		70		8.6	75	1450	included in the KIT		S	FRE	--	--	D1	L1	H	45	L	
Toyota Hiace (H12, H12G), inc. 4WD (H18, H18G), inc. facelift 07-	09/95-		335 230 600 001	→ 	60	18.4	12.0	80	2000	335 025 300 113	additional cable for continuous plus (Please order additionally.)		--	--	--	E1	D	L	V	75	L	
					335 356 600 001		60	19.4	12.0	80		2000	335 229 300 113	S	FRE	--	--	D1	L1	H	45	B
Toyota Hilux Double Cab, 4x4 inc. towball 329059600001 only vehicles with underrun guard official type ident no. of vehicle's type plate: ABE Nr. L642	05-10/10		335 409 600 001		30	10.0	13.8	120	2500	335 328 300 107			S	FRE	--	E1	--	--	V	75	B	
												335 328 300 113	S	FRE	--	E1	D1	L1	V	75	B	
			KIT			335 409 900 107		30	12.0	13.8		120	2500	included in the KIT								
KIT		335 409 900 113		30	12.0	13.8	120	2500	S	FRE	--	E1	--		--	V	75	B				





















Toyota

Toyota Hilux Double Cab, 4x4 inc. towball 329059600001 only vehicles with underrun guard official type ident no. of vehicle's type plate: e11*2007/46*0148	10/10-			335 408 600 001			30	10.0	13.8	120	2500		335 328 300 107			S	FRE	--	E1	--	--	V	75	B	
														335 328 300 113			S	FRE	--	E1	D1	L1	V	75	B
		KIT		335 408 900 107			30	12.0	13.8	120	2500			included in the KIT			S	FRE	--	E1	--	--	V	75	B
		KIT		335 408 900 113			30	12.0	13.8	120	2500					S	FRE	--	E1	--	--	V	75	B	
Toyota Hilux Extra Cab, 4x4 inc. towball 329059600001 only vehicles with underrun guard official type ident no. of vehicle's type plate: ABE Nr. L643	05-08/10			335 409 600 001			30	10.0	13.8	120	2500		335 328 300 107			S	FRE	--	E1	--	--	V	75	B	
														335 328 300 113			S	FRE	--	E1	D1	L1	V	75	B
		KIT		335 409 900 113			30	12.0	13.8	120	2500			included in the KIT			S	FRE	--	E1	D1	L1	V	75	B
Toyota Hilux Extra Cab, 4x4 inc. towball 329059600001 only vehicles with underrun guard official type ident no. of vehicle's type plate: ABE Nr. L642	05-08/10	KIT		335 409 900 107			30	12.0	13.8	120	2500			included in the KIT			S	FRE	--	E1	--	--	V	75	B
Toyota Hilux Extra Cab, 4x4 inc. towball 329059600001 only vehicles with underrun guard official type ident no. of vehicle's type plate: e11*2007/46*0149	08/10-			335 408 600 001			30	10.0	13.8	120	2500		335 328 300 107			S	FRE	--	E1	--	--	V	75	B	
														335 328 300 113			S	FRE	--	E1	D1	L1	V	75	B
		KIT		335 408 900 107			30	12.0	13.8	120	2500			included in the KIT			S	FRE	--	E1	--	--	V	75	B
		KIT		335 408 900 113			30	12.0	13.8	120	2500					S	FRE	--	E1	--	--	V	75	B	
Toyota Hilux Single Cab, 4x4 inc. towball 329059600001 only vehicles with underrun guard official type ident no. of vehicle's type plate: e11*2007/46*0148	10/10-			335 408 600 001			30	10.0	13.8	120	2500		335 328 300 107			S	FRE	--	E1	--	--	V	75	B	
														335 328 300 113			S	FRE	--	E1	D1	L1	V	75	B
		KIT		335 408 900 107			30	12.0	13.8	120	2500			included in the KIT			S	FRE	--	E1	--	--	V	75	B
		KIT		335 408 900 113			30	12.0	13.8	120	2500					S	FRE	--	E1	--	--	V	75	B	
Toyota Landcruiser J9	08/96-03			335 196 600 001	→		90	26.5	15.4	130	3500		300 072 300 107			--	FRE	--	--	--	--	V		B	
														300 072 300 113			--	FRE	--	--	D1	L1	V		B



















Toyota Landcruiser J 9, towing bracket inc. towball 32906260001	08/96-03		335 198 600 001	→		90	28.0	15.4	130	3500		300 072 300 107				--	FRE	--	--	--	--	V		B
												300 072 300 113					FRE							--
Toyota Landcruiser J 12	01/03-10/09		335 294 600 001			75	8.5	16.3	130	3500		300 210 300 107				--	A	--	--	--	--	V		B
												300 210 300 113					A							--
Toyota Landcruiser J 12 exc. vehicles with spare wheel under the vehicle ball approx. 40 mm deeper.	01/03-10/09		335 295 600 001	→		75	12.5	16.3	130	2800		300 210 300 107				--	A	--	--	--	--	V		B
												300 210 300 113					A							--
Toyota Landcruiser J 12 towing bracket for towballs and automatic bolt coupling matching towball: 32906260001	01/03-10/09		335 299 600 001	→		90	7.0	16.3	130	3500		300 210 300 107				--	A	--	--	--	--	V		B
												300 210 300 113					A							--
Toyota Landcruiser J 15 fitting towballs: 329062600001,329042600001, 329072600001. Please order separately cover for bumper cutout at Toyota dealers.	11/09-		335 397 600 001			16.0	15.9	130	3500			300 210 300 107				--	A	--	--	--	--	V		B
												335 398 300 113					S							A
Toyota Landcruiser J 15 inc. towball: 329062600001 Please order separately cover for bumper cutout at Toyota dealers.	11/09-	KIT		335 397 900 113			18.0	15.9	130	3500		included in the KIT				S	A	--	--	D	L1	H	75	B
Toyota Landcruiser J 15 exc. vehicles with spare wheel under the vehicle Please order separately cover for bumper cutout at Toyota dealers.	11/09-		335 398 600 001	→		17.0	15.9	130	3500			300 210 300 107				--	A	--	--	--	--	V		B
												335 398 300 113					S							A
Toyota Landcruiser V8 / 200	08-		335 359 600 001			90	15.0	17.2	140	3500		300 210 300 113				--	A	--	E1	D1	L1	V	90	B
												335 360 600 001												90











Toyota

Toyota Pro Ace	04/12-		306 331 600 001		75	22.5	12.2	122	2200	304 400 300 107	S	CAN	C1	E	--	--	H	105	B									
				306 333 600 001		75	22.5	12.2	122	2200	304 400 300 113	S	CAN	C1	E	D	L1	H	105	B								
		KIT		306 331 900 113		75	22.5	12.2	122	2200	included in the KIT	S	CAN	C1	E	D	L1	H	105	B								
				306 333 900 113		75	24.5	12.2	122	2200																		
Toyota RAV4 FunCruiser, 3 and 5 doors and convertible	06/94-05/00		335 194 600 001		60	16.7	8.8	75	1745	300 061 300 107	--	C2	--	E1	--	--	V		B									
										300 061 300 113	--	C2	--	--	--	V		B										
Toyota RAV4 not with rear step	06/00-02/06		335 246 600 001		>150	16.7	9.8	75	2000	335 250 300 113	S	FRE	--	E1	D1	L1	H	60	B									
				335 250 600 001		>150	21.0	9.8	75											2000								
Toyota RAV4 only for Executive and/or vehicles without spare wheel on the tailgate	03/06-13		335 324 600 001		90	33.5	10.4	90	2000	335 251 300 107	S	FRE	--	--	--	--	H	60	B									
										335 251 300 113										S	FRE	--	--	D1	L1	H	60	B
										335 251 300 183										S	--	--	E1	D	L	V	60	B
		KIT		335 347 600 001		90	35.0	10.4	90	2000	included in the KIT	S	FRE	--	--	D1	L1	H	60	B								
335 251 300 183	S										--										--	E1	D	L	V	60	B	
Toyota RAV4 all models	03/06-13		335 325 600 001		90	36.0	10.4	90	2000	335 251 300 107	S	FRE	--	--	--	--	H	60	B									
										335 251 300 113										S	FRE	--	--	D1	L1	H	60	B
										335 251 300 183										S	--	--	E1	D	L	V	60	B
		KIT		335 348 600 001		90	37.0	10.4	90	2000	included in the KIT	S	FRE	--	--	D1	L1	H	60	B								
335 251 300 183	S										--										--	E1	D	L	V	60	B	













Toyota RAV4	02/13-			335 418 600 001		120	37.0	10.9	80	2000	335 419 300 113				S	A	--	E1	D	L1	H	60	B	
				335 419 600 001		120	38.0	10.9	80	2000														
		KIT		335 418 900 113		120	37.0	10.9	80	2000														included in the KIT
		KIT		335 419 900 113		120	40.0	10.9	80	2000														
Toyota Urban Cruiser, 2 WD	03/09-			335 366 600 001	→	90	21.0	6.0	50	980	335 393 300 113			S	A	--	--	D	L1	V	120	B		
				335 368 600 001		90	21.0	6.0	50	980														
				335 367 600 001		90	22.0	6.0	50	980														
Toyota Urban Cruiser, 4 WD	03/09-			335 392 600 001	→	90	20.0	6.0	50	980	335 393 300 113			S	A	--	--	D	L1	V	120	B		
				335 394 600 001		90	20.0	6.0	50	980														
				335 393 600 001		90	20.5	6.0	50	980														
Toyota Verso	04/09-			335 400 600 001		90	19.5	9.3	60	1500	335 411 300 107			S	FRE	--	E1	--	--	V	120	B		
				335 421 600 001			90	22.0	9.3	60	1500												335 411 300 113	
		KIT		335 400 900 113			90	21.0	9.3	60	1500												included in the KIT	
		KIT		335 421 900 113			90	23.0	9.3	60	1500													



























Toyota





Toyota Verso S	01/11-		335 413 600 001		60	17.5	5.8	50	900	335 413 300 107			S	FRE	--	--	--	--	V	105	B
			335 414 600 001		60	17.5	5.8	50	900	335 413 300 113			S	FRE	--	--	D1	L1	V	105	B
	KIT		335 413 900 113		60	19.5	5.8	50	900	included in the KIT			S	FRE	--	--	D1	L1	V	105	B
			335 414 900 113		60	19.5	5.8	50	900				S	FRE	--	--	D1	L1	V	105	B
Toyota Yaris inc. T-Spirit and T-Sport	99-01/06		335 280 600 001		105	15.0	6.0	50	1000	300 072 300 113			--	FRE	--	--	D1	L1	V		B
Toyota Yaris exc. SR & T-Sport, inc. T-Spirit	01/06-10/11		335 350 600 001		60	17.0	6.8	75	1200	335 411 300 107	-09/11	S	FRE	--	E1	--	--	V	120	B	
										335 411 300 113	-09/11	S	FRE	--	E1	D1	L1	V	120	B	
Toyota Yaris exc. TS -09/11	01/06-07/14		335 383 600 001		75	18.7	6.8	50	1200	335 383 300 107	10/11-07/14	S	FRE	--	--	--	--	V	120	B	
										335 383 300 113	10/11-07/14	S	FRE	--	--	D1	L1	V	120	B	
										335 411 300 107	-09/11	S	FRE	--	E1	--	--	V	120	B	
										335 411 300 113	-09/11	S	FRE	--	E1	D1	L1	V	120	B	
Toyota Yaris exc. SR & T-Sport, inc. T-Spirit	10/11-07/14		335 382 600 001		60	17.0	6.7	50	1150	335 383 300 107		S	FRE	--	--	--	--	V	120	B	
										335 383 300 113		S	FRE	--	--	D1	L1	V	120	B	
		KIT		335 382 900 113		60	19.0	6.7	50	1150	included in the KIT			S	FRE	--	--	D1	L1	V	120
KIT		335 383 900 113		75	20.7	6.8	50	1200				S	FRE	--	--	D1	L1	V	120	B	

Toyota Yaris	08/14-			335 454 600 001		60	19.0	5.9	50	960		335 455 300 113	07/14-	S	FRE	--	E1	D1	L1	V	90	B
				335 455 600 001		75	19.0	6.8	50	1150												
		KIT		335 454 900 113		60	21.0	5.9	50	960		included in the KIT	07/14-	S	FRE	--	E1	D1	L1	V	90	B
		KIT		335 455 900 113		75	21.0	6.8	50	1150												
Toyota Yaris Verso	99-01/06			335 281 600 001		105	19.5	6.1	50	1000		300 072 300 107		--	FRE	--	--	--	--	V		B
												300 072 300 113		--	FRE	--	--	D1	L1	V		B



Volkswagen



VW Amarok for vehicles without bumper universal HGV towing bracket inc. towball 329059600001 swap system + coupling system possible	08/10-		321 794 600 001				28.5	14.3	100	2800		321 704 300 107	with preliminary setup	S	CAN	C	E	--	--	H	15	B	
												321 704 300 113	with preliminary setup	S	CAN	C	E	D	--	H	15	B	
												321 705 300 113	without preliminary setup	S	CAN	C	E	D	--	V	150	L	
VW Amarok for vehicles with bumper with integrated step towing bracket inc. Towball	08/10-		321 835 600 001			30	10.0	15.7	130	3200		321 704 300 107	with preliminary setup	S	CAN	C	E	--	--	H	15	B	
												321 704 300 113	with preliminary setup	S	CAN	C	E	D	--	H	15	B	
												321 705 300 113	without preliminary setup	S	CAN	C	E	D	--	V	150	L	
VW Amarok for vehicles with bumper with integrated step	08/10-		321 831 600 001			30	3.9	15.7	130	3200		321 704 300 107	with preliminary setup	S	CAN	C	E	--	--	H	15	B	
												321 704 300 113	with preliminary setup	S	CAN	C	E	D	--	H	15	B	
												321 705 300 113	without preliminary setup	S	CAN	C	E	D	--	V	150	L	
VW Beetle inc. convertible exc. vehicles with park distance control, exc. Rsi	98-09/11		321 468 600 001		>150	17.8	8.3	75	1500			300 073 300 113		--	FRE	--	--	D1	L1	V	90	B	
VW Bora Saloon exc. Syncro - 4-Motion	10/98-		305 222 600 001		90	17.5	8.9	75	1650			321 465 300 107		S	FRE	--	E	--	--	H	60	B	
			305 223 600 001		90	16.8	8.9	75	1650			321 465 300 113		S	FRE	--	E	D1	L1	H	60	B	
		KIT		321 457 900 113		90	19.5	8.9	75	1650					S	FRE	--	E	D1	L1	H	60	B
		KIT		321 465 900 113		90	18.8	8.9	75	1650			included in the KIT		S	FRE	--	E	D1	L1	H	60	B

VW Bora Estate exc. Syncro - 4-Motion	10/98-			305 222 600 001		90	17.5	8.9	75	1650		321 457 300 107			S	FRE	--	E	--	--	H	60	B
				305 223 600 001		90	16.8	8.9	75	1650		321 457 300 113			S	FRE	--	E	D1	L1	H	60	B
		KIT		305 222 900 113		90	19.5	8.9	75	1650		included in the KIT			S	FRE	--	E	D1	L1	H	60	B
		KIT		305 223 900 113		90	18.8	8.9	75	1650						S	FRE	--	E	D1	L1	H	60
VW Bora Estate 4-Motion exc. V6	10/97-			305 277 600 001		120	17.0	8.9	75	1650		321 457 300 107			S	FRE	--	E	--	--	H	60	B
												321 457 300 113			S	FRE	--	E	D1	L1	H	60	B
VW CC for right-hand-drive vehicles	12-	KIT		321 808 600 001		90	23.0	11.3	95	2200		included in the KIT			S	CAN	C	E	D	L1	V	90	R
VW CC	12-	KIT		321 824 600 001		90	23.0	11.3	95	2200		included in the KIT			S	CAN	C	E	D	L1	V	90	L
VW CC	12-			321 821 600 001		90	17.5	11.3	90	2200		321 600 300 107			S	CAN	C	E	--	--	V	105	L
				321 822 600 001		90	17.5	11.3	90	2200		321 600 300 113			S	CAN	C	E	D	L1	V	105	L
				321 823 600 001		90	20.0	11.3	90	2200		321 600 300 153			S	CAN	C	E	D	L1	V	105	R
		KIT		321 821 900 113		90	19.5	11.3	90	2200		included in the KIT			S	CAN	C	E	D	L1	V	105	L
		KIT		321 823 900 113		90	22.0	11.3	90	2200						S	CAN	C	E	D	L1	V	105
		VW CC B7 for right-hand-drive vehicles	01/12-	KIT		321 821 900 153		90	17.5	11.3	90	2200		included in the KIT			S	CAN	C	E	D	L1	V
KIT				321 823 900 153		90	22.0	11.3	90	2200						S	CAN	C	E	D	L1	V	105











VW Caddy III / Caddy Life for Caddy Maxi exc. vehicles with gas drive bracket for bumper inc. Please order at VW dealers: receptor box for detachable ball 2K0 804 969.	09/10-	KIT		321 660 900 113			75	20.0	9.4	80	1650		included in the KIT		09/10-	S	CAN	C	E	D	L1	V	105	L
VW Caddy Van	11/95-12/03			321 437 600 001			90	15.0	6.7	50	1100		344 503 300 107 344 503 300 113			S	C2	--	E1	--	--	H	45	L
VW Crafter Van types 46 and 50 Vehicles with 5,0 t max. total weight, reduction to 4,6 t max. total weight is possible wheelbase: 3665 mm For vehicles with integrated step device in the bumper the middle part of the outer bumper must be exchanged (Please order at VW dealers.). towball: 329059600001 Step VW is not utilisable. Utilisable step: 313285600001 or 313440600001	04/06-			313 272 600 001			120	21.0	20.2	150	3500		313 105 300 107 313 105 300 113 313 107 300 107 313 107 300 113 313 108 300 113 321 106 300 113		-12/14 for vehicles without preparation -12/14 for vehicles without preparation 01/15- for vehicles without preparation 01/15- for vehicles without preparation 01/15- for vehicles with preparation -12/14 vehicles with preparation	S	CAN	C	E	--	--	V	90	B























Volkswagen

VW Crafter Van types 46 and 50 Vehicles with 5,0 t max. total weight, reduction to 4,6 t max. total weight is possible wheelbase: 4325 mm For vehicles with integrated step device in the bumper the middle part of the outer bumper must be exchanged (Please order at VW dealers.). towball: 329059600001 Step VW is not utilisable.	04/06-		313 273 600 001			120	21.0	20.2	150	3500		313 105 300 107	-12/14 for vehicles without preparation	S	CAN	C	E	--	--	V	90	B	
												313 105 300 113	-12/14 for vehicles without preparation	S	CAN	C	E	D1	--	V	90	B	
												313 107 300 107	01/15- for vehicles without preparation	S									
												313 107 300 113	01/15- for vehicles without preparation	S									
												313 108 300 113	01/15- for vehicles with preparation	S									
												321 106 300 113	-12/14 vehicles with preparation	S	CAN	C	E	D	--	H	45	B	
VW Crafter Van types 30/35/38 Vehicles with 3,0 and 3,5 t max. total weight, increase to 3,8 t max. total weight is possible For vehicles with integrated step device in the bumper the middle part of the outer bumper must be exchanged (Please order separately at VW dealers.). suitable towball: 329059600001 Step VW is not utilisable. Utilisable step: 313285600001 or 313440600001	04/06-		313 376 600 001			120	20.0	18.1	150	3500		313 105 300 107	-12/14 for vehicles without preparation	S	CAN	C	E	--	--	V	90	B	
												313 105 300 113	-12/14 for vehicles without preparation	S	CAN	C	E	D1	--	V	90	B	
												313 107 300 107	01/15- for vehicles without preparation	S									
												313 107 300 113	01/15- for vehicles without preparation	S									
												313 108 300 113	01/15- for vehicles with preparation	S									
												321 106 300 113	-12/14 vehicles with preparation	S	CAN	C	E	D	--	H	45	B	





















VW Crafter Van types 30/35/38 Vehicles with 3,0 and 3,5 t max. total weight, increase to 3,8 t max. total weight is possible For vehicles with integrated step device in the bumper the middle part of the outer bumper must be exchanged (Please order separately at VW dealers.). suitable towball: 329059600001 Step VW is not utilisable. Utilisable step: 313285600001 or 313440600001	04/06-12/14	KIT		313 376 900 113			120	22.0	18.1	150	3500		included in the KIT		-12/14 for vehicles without preparation	S	CAN	C	E	D1	--	V	90	B
VW Crafter Chassis Cab types 46 and 50 Vehicles with 5,0 t max. total weight, reduction to 4,6 t max. total weight is possible wheelbase: 3665 + 4325 mm towball: 329059600001 If there is an underrun guard mounted, please change into VW no. 2E3 805 721 A.	04/06-			313 275 600 001			90	18.0	20.2	150	3500		313 105 300 107		-12/14 for vehicles without preparation	S	CAN	C	E	--	--	V	90	B
													313 105 300 113		-12/14 for vehicles without preparation	S	CAN	C	E	D1	--	V	90	B
													313 107 300 107		01/15- for vehicles without preparation	S								
													313 107 300 113		01/15- for vehicles without preparation	S								
													313 108 300 113		01/15- for vehicles with preparation	S								
													321 106 300 113		-12/14 vehicles with preparation	S	CAN	C	E	D	--	H	45	B





















Volkswagen

VW Crafter Chassis Cab types 30/35/38 Vehicles with 3,0 and 3,5 t max. total weight, increase to 3,8 t max. total weight is possible exc. vehicles with underrun guard towball: 329059600001	04/06-			313 377 600 001			90	20.0	18.1	150	3500		313 105 300 107	-12/14 for vehicles without preparation	S	CAN	C	E	--	--	V	90	B
							313 105 300 113	-12/14 for vehicles without preparation	S	CAN	C		E	D1	--	V	90	B					
							313 107 300 107	01/15- for vehicles without preparation	S														
							313 107 300 113	01/15- for vehicles without preparation	S														
							313 108 300 113	01/15- for vehicles with preparation	S														
							321 106 300 113	-12/14 vehicles with preparation	S	CAN	C		E	D	--	H	45	B					
VW Crafter Chassis Cab types 46 and 50 Vehicles with 5,0 t max. total weight, reduction to 4,6 t max. total weight is possible wheelbase: 3665 + 4325 mm towball: 329059600001 If there is an underrun guard mounted, please change into VW no. 2E3 805 721 A.	04/06-12/14	KIT		313 275 900 113			90	20.0	20.2	150	3500		included in the KIT	-12/14 for vehicles without preparation	S	CAN	C	E	D1	--	V	90	B
VW Crafter Chassis Cab types 30/35/38 Vehicles with 3,0 and 3,5 t max. total weight, increase to 3,8 t max. total weight is possible exc. vehicles with underrun guard towball: 329059600001	04/06-12/14	KIT		313 377 900 113			90	22.0	18.1	150	3500		included in the KIT	-12/14 for vehicles without preparation	S	CAN	C	E	D1	--	V	90	B
VW Eos Coupé/Convertible Please order spoiler inc. cover for bumper cutout at VW-dealers. inc. facelift 01/11-	06/06-			321 543 600 001			75	18.0	9.3	100	1800		321 546 300 113		S	CAN	C	E	D	L1	V	90	B
													321 600 300 113		S	CAN	C	E	D	L1	V	105	L
VW Fox exc. Cross Fox	10/05-			321 690 600 001			55	14.5	6.7	50	800		321 526 300 113		S	FRE	--	E	--	--	H	45	L
VW Golf III Hatchback and saloon 4x4, convertible from 09/93-97	11/91-09/97			321 331 600 001			90	15.5	8.2	75	1500		321 331 300 107		S	C2	--	E1	--	--	H	45	B
													321 331 300 113		S	C2	--	E1	D1	--	H	45	B











VW Golf III Estate exc. Syncro	10/93-07/99		321 327 600 001		90	13.9	8.3	75	1500	321 331 300 107			S	C2	--	E1	--	--	H	45	B	
																S	C2	--	E1	D1	--	H
VW Golf IV Hatchback exc. Syncro - 4-Motion and convertible exc. Golf R32 / 241 PS	10/97-		305 222 600 001		90	17.5	8.9	75	1650	321 465 300 107			S	FRE	--	E	--	--	H	60	B	
			305 223 600 001		90	16.8	8.9	75	1650	321 465 300 113			S	FRE	--	E	D1	L1	H	60	B	
		KIT		321 457 900 113		90	19.5	8.9	75	1650	included in the KIT			S	FRE	--	E	D1	L1	H	60	B
		KIT		321 465 900 113		90	18.8	8.9	75	1650				S	FRE	--	E	D1	L1	H	60	B
VW Golf IV Hatchback 4-Motion exc. vehicles with V6 motor	10/97-		305 277 600 001		120	17.0	8.9	75	1650	321 465 300 107			S	FRE	--	E	--	--	H	60	B	
													S	FRE	--	E	D1	L1	H	60	B	
VW Golf IV Estate exc. Syncro - 4-Motion and convertible exc. Golf R32 / 241 PS	10/97-		305 222 600 001		90	17.5	8.9	75	1650	321 457 300 107			S	FRE	--	E	--	--	H	60	B	
			305 223 600 001		90	16.8	8.9	75	1650	321 457 300 113			S	FRE	--	E	D1	L1	H	60	B	
		KIT		305 222 900 113		90	19.5	8.9	75	1650	included in the KIT			S	FRE	--	E	D1	L1	H	60	B
		KIT		305 223 900 113		90	18.8	8.9	75	1650				S	FRE	--	E	D1	L1	H	60	B
VW Golf IV Estate 4-Motion	10/97-		305 277 600 001		120	17.0	8.9	75	1650	321 457 300 107			S	FRE	--	E	--	--	H	60	B	
													S	FRE	--	E	D1	L1	H	60	B	
VW Golf V Saloon exc. R/RS32 09/05- exc. R/R20 / 270 HP 09- inc. 4-Motion / Gti	11/03-		321 865 600 001		60	17.0	9.4	100	1800	321 600 300 107			S	CAN	C	E	--	--	V	105	L	
												321 600 300 113			S	CAN	C	E	D	L1	V	105
		KIT		321 750 900 113		60	18.5	9.4	100	1800	321 600 300 153			S	CAN	C	E	D	L1	V	105	R
									included in the KIT			S	CAN	C	E	D	L1	V	105	L		











Volkswagen

VW Golf V Saloon exc. R/RS32 09/05- exc. R/R20 / 270 HP 09- inc. 4-Motion / Gti Please order separately: spoiler and cover for bumper cutout at VW dealers.	11/03-			321 885 600 001		60	17.0	9.4	100	1800		321 600 300 107			S	CAN	C	E	--	--	V	105	L
													321 600 300 113			S	CAN	C	E	D	L1	V	105
												321 600 300 153			S	CAN	C	E	D	L1	V	105	R
		KIT		321 751 900 113		60	18.5	9.4	100	1800		included in the KIT			S	CAN	C	E	D	L1	V	105	L
VW Golf V Hatchback and Plus inc. Cross-Golf exc. RS32 09/05- exc. R20 / 270 HP 09- inc. 4-Motion / Gti	03/05-			321 865 600 001		60	17.0	9.4	100	1800		321 600 300 107			S	CAN	C	E	--	--	V	105	L
													321 600 300 113			S	CAN	C	E	D	L1	V	105
												321 600 300 153			S	CAN	C	E	D	L1	V	105	R
		KIT		321 750 900 113		60	18.5	9.4	100	1800		included in the KIT			S	CAN	C	E	D	L1	V	105	L
VW Golf V Hatchback and Plus inc. Cross-Golf exc. RS32 09/05- exc. R20 / 270 HP 09- inc. 4-Motion / Gti Please order separately: spoiler and cover for bumper cutout at VW dealers.	03/05-			321 885 600 001		60	17.0	9.4	100	1800		321 600 300 107			S	CAN	C	E	--	--	V	105	L
													321 600 300 113			S	CAN	C	E	D	L1	V	105
												321 600 300 153			S	CAN	C	E	D	L1	V	105	R
		KIT		321 751 900 113		60	18.5	9.4	100	1800		included in the KIT			S	CAN	C	E	D	L1	V	105	L
VW Golf V Estate inc. 4-Motion Please order spoiler at VW dealers.	06/07-			321 630 600 001		90	17.0	9.3	100	1800		321 600 300 107			S	CAN	C	E	--	--	V	105	L
													321 600 300 113			S	CAN	C	E	D	L1	V	105
												321 600 300 153			S	CAN	C	E	D	L1	V	105	R
		KIT		321 630 900 113		90	21.0	9.3	100	1800		included in the KIT			S	CAN	C	E	D	L1	V	105	L
VW Golf V Estate inc. 4-Motion	06/07-			321 662 600 001		90	17.0	9.3	100	1800		321 600 300 107			S	CAN	C	E	--	--	V	105	L
													321 600 300 113			S	CAN	C	E	D	L1	V	105
												321 600 300 153			S	CAN	C	E	D	L1	V	105	R
		KIT		321 662 900 113		90	19.0	9.3	100	1800		included in the KIT			S	CAN	C	E	D	L1	V	105	L













VW Golf VI Convertible cutout with stencil, alternative: spoiler + cover for cutout from VW dealers	06/11-			321 873 600 001		60	17.0	9.4	75	1800		305 256 300 107			S	CAN	C	E	--	--	V	120	B
												305 256 300 113			S	CAN	C	E	D	--	V	120	B
		KIT		321 730 900 113		60	19.0	9.4	75	1800		included in the KIT			S	CAN	C	E	D	--	V	120	B
VW Golf VI Saloon exc. R/RS32 09/05- exc. R/R20 / 270 HP 09- inc. 4-Motion / Gti	10/08-			321 865 600 001		60	17.0	9.4	100	1800		321 600 300 107			S	CAN	C	E	--	--	V	105	L
												321 600 300 113			S	CAN	C	E	D	L1	V	105	L
												321 600 300 153			S	CAN	C	E	D	L1	V	105	R
		KIT		321 750 900 113		60	18.5	9.4	100	1800		included in the KIT			S	CAN	C	E	D	L1	V	105	L
VW Golf VI Saloon exc. R/RS32 09/05- exc. R/R20 / 270 HP 09- inc. 4-Motion / Gti Please order separately: spoiler and cover for bumper cutout at VW dealers.	10/08-			321 885 600 001		60	17.0	9.4	100	1800		321 600 300 107			S	CAN	C	E	--	--	V	105	L
												321 600 300 113			S	CAN	C	E	D	L1	V	105	L
												321 600 300 153			S	CAN	C	E	D	L1	V	105	R
		KIT		321 751 900 113		60	18.5	9.4	100	1800		included in the KIT			S	CAN	C	E	D	L1	V	105	L
VW Golf VI Hatchback and Plus inc. Cross-Golf exc. RS32 09/05- exc. R20 / 270 HP 09- inc. 4-Motion / Gti	03/09-			321 865 600 001		60	17.0	9.4	100	1800		321 600 300 107			S	CAN	C	E	--	--	V	105	L
												321 600 300 113			S	CAN	C	E	D	L1	V	105	L
												321 600 300 153			S	CAN	C	E	D	L1	V	105	R
		KIT		321 750 900 113		60	18.5	9.4	100	1800		included in the KIT			S	CAN	C	E	D	L1	V	105	L
VW Golf VI Hatchback and Plus inc. Cross-Golf exc. RS32 09/05- exc. R20 / 270 HP 09- inc. 4-Motion / Gti Please order separately: spoiler and cover for bumper cutout at VW dealers.	03/09-			321 885 600 001		60	17.0	9.4	100	1800		321 600 300 107			S	CAN	C	E	--	--	V	105	L
												321 600 300 113			S	CAN	C	E	D	L1	V	105	L
												321 600 300 153			S	CAN	C	E	D	L1	V	105	R
		KIT		321 751 900 113		60	18.5	9.4	100	1800		included in the KIT			S	CAN	C	E	D	L1	V	105	L





















Volkswagen

VW Golf VI Estate inc. 4-Motion Please order spoiler at VW dealers.	06/09-			321 630 600 001		90	17.0	9.3	100	1800		321 600 300 107			S	CAN	C	E	--	--	V	105	L
												321 600 300 113			S	CAN	C	E	D	L1	V	105	L
												321 600 300 153			S	CAN	C	E	D	L1	V	105	R
		KIT		321 630 900 113		90	21.0	9.3	100	1800		included in the KIT			S	CAN	C	E	D	L1	V	105	L
VW Golf VI Estate inc. 4-Motion	06/09-			321 662 600 001		90	17.0	9.3	100	1800		321 600 300 107			S	CAN	C	E	--	--	V	105	L
												321 600 300 113			S	CAN	C	E	D	L1	V	105	L
												321 600 300 153			S	CAN	C	E	D	L1	V	105	R
		KIT		321 662 900 113		90	19.0	9.3	100	1800		included in the KIT			S	CAN	C	E	D	L1	V	105	L
VW Golf VII Saloon	10/12-			317 131 600 001		60	19.0	10.3	80	2000		305 403 300 107	-06/14 with preliminary setup	S	CAN	C	E	--	--	H	45	B	
												305 403 300 113	-06/14 with preliminary setup	S	CAN	C	E	--	--	H	45	B	
													305 406 300 107	-06/14 without preliminary setup	S	CAN	C	E	--	--	V	150	B
													305 406 300 113	-06/14 without preliminary setup	S	CAN	C	E	D	L1	V	150	B
													305 407 300 107	06/14- with preliminary setup	S	CAN	C	E	--	--	H		B
													305 407 300 113	06/14- with preliminary setup	S	CAN	C	E	D	L	H		B
													305 408 300 107	06/14- without preliminary setup	S	CAN	C	E	--	--	V		B
													305 408 300 113	06/14- without preliminary setup	S	CAN	C	E	D	L	V		B





















VW Golf VII Saloon Please order spoiler inc. cover for bumper cutout at VW-dealers.	10/12-			317 132 600 001		60	19.0	10.3	80	2000		305 403 300 107	-06/14 with preliminary setup	S	CAN	C	E	--	--	H	45	B
												305 403 300 113	-06/14 with preliminary setup	S	CAN	C	E	--	--	H	45	B
												305 406 300 107	-06/14 without preliminary setup	S	CAN	C	E	--	--	V	150	B
												305 406 300 113	-06/14 without preliminary setup	S	CAN	C	E	D	L1	V	150	B
												305 407 300 107	06/14- with preliminary setup	S	CAN	C	E	--	--	H		B
												305 407 300 113	06/14- with preliminary setup	S	CAN	C	E	D	L	H		B
												305 408 300 107	06/14- without preliminary setup	S	CAN	C	E	--	--	V		B
												305 408 300 113	06/14- without preliminary setup	S	CAN	C	E	D	L	V		B
VW Golf VII Saloon	10/12-06/14	KIT		317 131 900 113		60	21.0	10.3	85	2000		included in the KIT	-06/14 without preliminary setup	S	CAN	C	E	D	L1	V	150	B
VW Golf VII Saloon Please order spoiler inc. cover for bumper cutout at VW-dealers.	10/12-06/14	KIT		317 132 900 113		60	21.0	10.3	80	2000		included in the KIT	-06/14 without preliminary setup	S	CAN	C	E	D	L1	V	150	B
VW Golf VII Saloon	06/14-	KIT		305 408 900 113		60	19.0	10.3	85	2000		included in the KIT	06/14- without preliminary setup	S	CAN	C	E	D	L	V		B
VW Golf VII Saloon Please order spoiler inc. cover for bumper cutout at VW-dealers.	06/14-	KIT		305 409 900 113		60	21.0	10.3	85	2000		included in the KIT	06/14- without preliminary setup	S	CAN	C	E	D	L	V		B











Volkswagen

VW Golf VII Sportsvan	06/14-		321 868 600 001	→ 		16.0	10.0	80	2000		305 407 300 107	06/14- with preliminary setup	S	CAN	C	E	--	--	H		B	
				317 131 600 001		60	19.0	10.3	80	2000		305 407 300 113	06/14- with preliminary setup	S	CAN	C	E	D	L	H		B
				317 132 600 001		60	19.0	10.3	80	2000		305 408 300 107	06/14- without preliminary setup	S	CAN	C	E	--	--	V		B
												305 408 300 113	06/14- without preliminary setup	S	CAN	C	E	D	L	V		B
	KIT		321 868 900 113			21.0	10.0	80	2000		included in the KIT	06/14- without preliminary setup	S	CAN	C	E	D	L	V		B	
VW Golf VII Sportsvan Please order spoiler inc. cover for bumper cutout at VW-dealers.	06/14-		321 869 600 001	→ 		16.0	10.0	80	2000		305 407 300 107	06/14- with preliminary setup	S	CAN	C	E	--	--	H		B	
											305 407 300 113	06/14- with preliminary setup	S	CAN	C	E	D	L	H		B	
												305 408 300 107	06/14- without preliminary setup	S	CAN	C	E	--	--	V		B
												305 408 300 113	06/14- without preliminary setup	S	CAN	C	E	D	L	V		B
	KIT		321 869 900 113			21.0	10.0	80	2000		included in the KIT	06/14- without preliminary setup	S	CAN	C	E	D	L	V		B	























VW Golf VII Estate inc. 4 Motion	08/13-			321 781 600 001		60	16.0	10.2	80	2000		305 403 300 107	-06/14 with preliminary setup	S	CAN	C	E	--	--	H	45	B
				321 782 600 001		60	17.0	10.2	80	2000		305 403 300 113	-06/14 with preliminary setup	S	CAN	C	E	--	--	H	45	B
												305 406 300 107	-06/14 without preliminary setup	S	CAN	C	E	--	--	V	150	B
												305 406 300 113	-06/14 without preliminary setup	S	CAN	C	E	D	L1	V	150	B
												305 407 300 107	06/14- with preliminary setup	S	CAN	C	E	--	--	H		B
												305 407 300 113	06/14- with preliminary setup	S	CAN	C	E	D	L	H		B
												305 408 300 107	06/14- without preliminary setup	S	CAN	C	E	--	--	V		B
												305 408 300 113	06/14- without preliminary setup	S	CAN	C	E	D	L	V		B
VW Golf VII Estate inc. 4 Motion	08/13-06/14	KIT		321 781 900 113		60	18.0	10.2	80	2000		included in the KIT	-06/14 without preliminary setup	S	CAN	C	E	D	L1	V	150	B
				321 782 900 113		60	19.0	10.2	80	2000												
VW Golf VII Estate inc. 4 Motion	06/14-	KIT		321 783 900 113		60	18.0	10.2	80	2000		included in the KIT	06/14- without preliminary setup	S	CAN	C	E	D	L	V		B
				321 784 900 113		60	19.0	10.2	80	2000												
VW Jetta Please order spoiler at VW dealers.	08/05-12/10			321 630 600 001		90	17.0	9.3	100	1800		321 600 300 107		S	CAN	C	E	--	--	V	105	L
				321 600 300 113								321 600 300 113		S	CAN	C	E	D	L1	V	105	L
				321 600 300 153								321 600 300 153		S	CAN	C	E	D	L1	V	105	R
		KIT		321 630 900 113		90	21.0	9.3	100	1800		included in the KIT		S	CAN	C	E	D	L1	V	105	L



















Volkswagen

VW Jetta	08/05-12/10			321 662 600 001		90	17.0	9.3	100	1800		321 600 300 107			S	CAN	C	E	--	--	V	105	L	
												321 600 300 113			S	CAN	C	E	D	L1	V	105	L	
												321 600 300 153			S	CAN	C	E	D	L1	V	105	R	
		KIT		321 662 900 113		90	19.0	9.3	100	1800		included in the KIT			S	CAN	C	E	D	L1	V	105	L	
VW Jetta Please order separately Spoiler and cover for bumper cutout at VW dealer's.	01/11-			321 778 600 001		40	19.0	9.3	75	1800		321 600 300 107			S	CAN	C	E	--	--	V	105	L	
												321 600 300 113			S	CAN	C	E	D	L1	V	105	L	
												321 600 300 153			S	CAN	C	E	D	L1	V	105	R	
		KIT		321 778 900 113		40	21.0	9.3	75	1800		included in the KIT			S	CAN	C	E	D	L1	V	105	L	
VW Jetta	01/11-			321 825 600 001		40	17.0	9.3	75	1800		321 600 300 107			S	CAN	C	E	--	--	V	105	L	
												321 600 300 113			S	CAN	C	E	D	L1	V	105	L	
												321 600 300 153			S	CAN	C	E	D	L1	V	105	R	
		KIT		321 825 900 113		40	19.0	9.3	75	1800		included in the KIT			S	CAN	C	E	D	L1	V	105	L	
VW LT II The program for VW LT II can be found in the appendix.	03/96-03/06																							
VW Passat CC inc. 4-Motion exc. R36 Please order additionally lower part of the bumper with cover for bumper cutout at VW dealer.	03/05-12/12			321 546 600 001		90	17.5	11.3	90	2200		321 600 300 107			S	CAN	C	E	--	--	V	105	L	
												321 600 300 113			S	CAN	C	E	D	L1	V	105	L	
												321 600 300 153			S	CAN	C	E	D	L1	V	105	R	
		KIT		321 546 900 113		90	21.0	11.3	90	2200		included in the KIT			S	CAN	C	E	D	L1	V	105	L	
VW Passat CC B7 inc. Bluemotion for right-hand-drive vehicles	01/12-	KIT		321 821 900 153		90	17.5	11.3	90	2200		included in the KIT			S	CAN	C	E	D	L1	V	105	R	
VW Passat Saloon B4, all models	10/93-09/96			321 360 600 001			90	15.8	10.1	85	2000		300 060 300 107			--	C2	--	E1	--	--	H	45	B
													300 060 300 113			--	C2	--	E1	D1	L1	H	45	B









VW Passat Saloon front wheel drive exc. 4-Motion Support in spare wheel for detachable towball: 3B0 804 993A	10/96-03/05		321 505 600 001			90	20.8	10.3	85	1800		321 505 300 107 →	11/00-	S	FRE	--	E	--	--	V	60	B
												321 505 300 113	11/00-	S	FRE	--	E	D1	L1	V	60	B
												321 512 300 107	-10/00	S	FRE	--	E	--	--	V	60	B
												321 512 300 113	-10/00	S	FRE	--	E	D1	L1	V	60	B
VW Passat Saloon Syncro - 4-Motion and Passat W8 Support in spare wheel for detachable towball: 3B0 804 993A	10/96-03/05		321 508 600 001			90	21.0	11.3	85	2200		321 505 300 107 →	11/00-	S	FRE	--	E	--	--	V	60	B
												321 505 300 113	11/00-	S	FRE	--	E	D1	L1	V	60	B
												321 512 300 107	-10/00	S	FRE	--	E	--	--	V	60	B
												321 512 300 113	-10/00	S	FRE	--	E	D1	L1	V	60	B
VW Passat Saloon Syncro - 4-Motion and Passat W8	10/96-03/05		321 637 600 001			90	23.6	11.3	85	2200		321 505 300 107 →	11/00-	S	FRE	--	E	--	--	V	60	B
												321 505 300 113	11/00-	S	FRE	--	E	D1	L1	V	60	B
												321 512 300 107	-10/00	S	FRE	--	E	--	--	V	60	B
												321 512 300 113	-10/00	S	FRE	--	E	D1	L1	V	60	B
VW Passat Saloon front wheel drive exc. 4-Motion	10/96-03/05		321 874 600 001			120	17.0	10.5	85	2000		321 505 300 107 →	11/00-	S	FRE	--	E	--	--	V	60	B
												321 505 300 113	11/00-	S	FRE	--	E	D1	L1	V	60	B
												321 512 300 107	-10/00	S	FRE	--	E	--	--	V	60	B
												321 512 300 113	-10/00	S	FRE	--	E	D1	L1	V	60	B
VW Passat Saloon front wheel drive exc. 4-Motion	11/00-03/05	KIT 	321 772 900 113			120	25.0	10.5	85	2000		included in the KIT	11/00-	S	FRE	--	E	D1	L1	V	60	B
VW Passat Saloon inc. 4-Motion exc. R36	03/05-10/10		321 544 600 001			90	16.0	11.3	90	2200		321 600 300 107		S	CAN	C	E	--	--	V	105	L
												321 600 300 113		S	CAN	C	E	D	L1	V	105	L
		KIT 	321 544 900 113			90	18.0	12.3	90	2200		included in the KIT		S	CAN	C	E	D	L1	V	105	L





















Volkswagen

VW Passat Saloon inc. 4-Motion exc. R36 Please order additionally lower part of the bumper with cover for bumper cutout at VW dealer.	03/05-10/10			321 546 600 001		90	17.5	11.3	90	2200									S	CAN	C	E	--	--	V	105	L			
																				S	CAN	C	E	D	L1	V	105	L		
																				S	CAN	C	E	D	L1	V	105	R		
		KIT		321 546 900 113		90	21.0	11.3	90	2200										S	CAN	C	E	D	L1	V	105	L		
VW Passat Saloon inc. 4-Motion, inc. R36 Please order additionally lower part of the bumper with cover for bumper cutout at VW dealer. for right-hand-drive vehicles	03/05-10/10	KIT		321 546 900 153		90	21.0	11.3	90	2200										S	CAN	C	E	D	L1	V	105	R		
VW Passat Saloon B7 R-Line = visible cut for right-hand-drive vehicles	10/10-11/14	KIT		321 808 600 001		90	23.0	11.3	95	2200										S	CAN	C	E	D	L1	V	90	R		
VW Passat Saloon B7 R-Line = visible cut	10/10-11/14	KIT		321 824 600 001		90	23.0	11.3	95	2200										S	CAN	C	E	D	L1	V	90	L		
VW Passat Saloon B7 R-Line = visible cut	10/10-11/14			321 821 600 001		90	17.5	11.3	90	2200										S	CAN	C	E	--	--	V	105	L		
																					S	CAN	C	E	D	L1	V	105	L	
					321 822 600 001		90	17.5	11.3	90	2200											S	CAN	C	E	D	L1	V	105	R
					321 823 600 001		90	20.0	11.3	90	2200																			
				KIT		321 821 900 113		90	19.5	11.3	90	2200											S	CAN	C	E	D	L1	V	105
		KIT		321 823 900 113		90	22.0	11.3	90	2200																				
VW Passat Saloon B7 inc. Alltrack, Bluemotion R-Line = visible cut for right-hand-drive vehicles	10/10-11/14	KIT		321 823 900 153		90	22.0	11.3	90	2200											S	CAN	C	E	D	L1	V	105	R	

























VW Passat Saloon B7 inc. Bluemotion for right-hand-drive vehicles	10/10-11/14	KIT		321 821 900 153		90	17.5	11.3	90	2200		included in the KIT			S	CAN	C	E	D	L1	V	105	R	
VW Passat Saloon B8	11/14-			321 862 600 001			16.0	11.5	100	2200		305 408 300 107			S	CAN	C	E	--	--	V		B	
				321 863 600 001			17.0	11.5	100	2200		305 408 300 113			S	CAN	C	E	D	L	V			B
		KIT		321 862 900 113			18.0	11.5	100	2200		included in the KIT			S	CAN	C	E	D	L	V			B
		KIT		321 863 900 113			19.0	11.5	100	2200		included in the KIT			S	CAN	C	E	D	L	V			B
VW Passat Estate B7 inc. Bluemotion for right-hand-drive vehicles		KIT		321 821 900 153		90	17.5	11.3	90	2200		included in the KIT			S	CAN	C	E	D	L1	V	105	R	
VW Passat Estate B4, all models	10/93-04/97			321 360 600 001	 	90	15.8	10.1	85	2000		321 361 300 107			S	C2	--	E1	--	--	H	45	L	
												321 361 300 113		S	C2	--	E1	D1	L1	H	45	L		
VW Passat Estate Syncro - 4-Motion and Passat W8 from 11/00: To guarantee an optimal fit of the bumper it is necessary to mount a bumper reinforcement, please order from VW-dealer, order no. 3B9 807 251A Support for detachable towball in spare wheel: 3B0 804 993A	10/96-09/05			321 508 600 001		90	21.0	11.3	85	2200		321 512 300 107	-10/00	S	FRE	--	E	--	--	V	60	B		
												321 512 300 113	-10/00	S	FRE	--	E	D1	L1	V	60	B		
												321 520 300 107	11/00-	S	FRE	--	E	--	--	V	60	L		
												321 520 300 113	11/00-	S	FRE	--	E	D1	L1	V	60	L		
VW Passat Estate Syncro - 4-Motion and Passat W8 Variant from 11/00: To guarantee an optimal fit of the bumper it is necessary to mount a bumper reinforcement, please order from VW-dealer, order no. 3B9 807 251A	10/96-09/05			321 637 600 001		90	23.6	11.3	85	2200		321 512 300 107	-10/00	S	FRE	--	E	--	--	V	60	B		
												321 512 300 113	-10/00	S	FRE	--	E	D1	L1	V	60	B		
												321 520 300 107	11/00-	S	FRE	--	E	--	--	V	60	L		
												321 520 300 113	11/00-	S	FRE	--	E	D1	L1	V	60	L		

























Volkswagen

VW Passat Estate front wheel drive exc. 4-Motion from 11/00: To guarantee an optimal fit of the bumper it is necessary to mount a bumper reinforcement, please order from VW-dealer, order no. 3B9 807 251A Support for detachable towball in spare wheel: 3B0 804 993A	04/97-09/05		321 505 600 001			90	20.8	10.3	85	1800		321 512 300 107	-10/00	S	FRE	--	E	--	--	V	60	B
						321 512 300 113	-10/00	S	FRE	--		E	D1	L1	V	60	B					
						321 520 300 107	11/00-	S	FRE	--		E	--	--	V	60	L					
						321 520 300 113	11/00-	S	FRE	--		E	D1	L1	V	60	L					
VW Passat Estate front wheel drive exc. 4-Motion	04/97-09/05		321 874 600 001			120	17.0	10.5	85	2000		321 512 300 107	-10/00	S	FRE	--	E	--	--	V	60	B
						321 512 300 113	-10/00	S	FRE	--		E	D1	L1	V	60	B					
						321 520 300 107	11/00-	S	FRE	--		E	--	--	V	60	L					
						321 520 300 113	11/00-	S	FRE	--		E	D1	L1	V	60	L					
VW Passat Estate front wheel drive exc. 4-Motion from 11/00: To guarantee an optimal fit of the bumper it is necessary to mount a bumper reinforcement, please order from VW-dealer, order no. 3B9 807 251A Support for detachable towball in spare wheel: 3B0 804 993A	11/00-09/05	KIT		321 505 900 113		90	24.0	10.3	85	2000		included in the KIT	11/00-	S	FRE	--	E	D1	L1	V	60	L
VW Passat Estate front wheel drive exc. 4-Motion	11/00-09/05	KIT		321 632 900 113		120	25.0	10.0	85	2000		included in the KIT	11/00-	S	FRE	--	E	D1	L1	V	60	L
VW Passat Estate inc. 4-Motion, inc. R36 08/05-: To guarantee an optimal fit of the bumper order bumper reinforcement from VW-dealer order no. 3C9 807 251 A.	09/05-10/10			321 544 600 001		90	16.0	11.3	90	2200		321 600 300 107		S	CAN	C	E	--	--	V	105	L
				321 546 600 001		90	17.5	11.3	90	2200		321 600 300 113		S	CAN	C	E	D	L1	V	105	L
		KIT		321 544 900 113		90	18.0	12.3	90	2200		included in the KIT		S	CAN	C	E	D	L1	V	105	L
		KIT		321 546 900 113		90	21.0	11.3	90	2200				S	CAN	C	E	D	L1	V	105	L



















VW Polo inc. R-Line	06/09-04/14	KIT		321 741 900 113		120	17.0	7.0	85	1200	included in the KIT	-04/14	S	CAN	C	E	D1	L1	V	105	L	
		KIT		321 741 900 143		120	17.0	7.0	85	1200												
VW Polo If desired for optical reasons, it is possible to get the complete bumper inc. cover at VW dealers. inc. R-Line 2012-extension for socket holder necessary, order no. 921740650010	06/09-04/14	KIT		321 748 900 113		120	18.5	7.0	85	1200	included in the KIT	-04/14	S	CAN	C	E	D1	L1	V	105	L	
		KIT		321 748 900 143		120	18.5	7.0	85	1200												
VW Polo	04/14-	KIT		321 832 900 113		120	16.5	7.0	50	1200	included in the KIT	04/14-	S	CAN								
		KIT		321 878 900 113		120	18.5	7.0	50	1200												
VW Polo Bluemotion Please check if there is a towing capacity in the car documents.	06/09-			321 741 600 001	→ 	120	15.0	7.0	85	1200	321 527 300 107	-04/14	S	CAN	C	E	--	--	V	105	L	
				321 527 300 113	-04/14	S	CAN	C	E	D1	L1	V	105	L								
				321 527 300 143		S									R							
				321 529 300 107	04/14-	S	CAN															
				321 529 300 113	04/14-	S	CAN															
VW Polo Bluemotion Please order separately extension for socket holder, order no. 921740650001. Please check if there is a towing capacity in the car documents.	06/09-			321 748 600 001	→ 	120	16.5	7.0	85	1200	321 527 300 107	-04/14	S	CAN	C	E	--	--	V	105	L	
				321 527 300 113	-04/14	S	CAN	C	E	D1	L1	V	105	L								
				321 527 300 143		S									R							
				321 529 300 107	04/14-	S	CAN															
				321 529 300 113	04/14-	S	CAN															
VW Polo Bluemotion Please check if there is a towing capacity in the car documents.	06/09-04/14	KIT		321 741 900 113		120	17.0	7.0	85	1200	included in the KIT	-04/14	S	CAN	C	E	D1	L1	V	105	L	
		KIT		321 741 900 143		120	17.0	7.0	85	1200												

Volkswagen























VW Polo Bluemotion Please order separately extension for socket holder, order no. 921740650001. Please check if there is a towing capacity in the car documents.	06/09-04/14	KIT		321 748 900 113			120	18.5	7.0	85	1200		included in the KIT	-04/14	S	CAN	C	E	D1	L1	V	105	L	
		KIT		321 748 900 143			120	18.5	7.0	85	1200													
VW Polo Bluemotion Please check if there is a towing capacity in the car documents.	04/14-	KIT		321 832 900 113			120	16.5	7.0	50	1200		included in the KIT	04/14-	S	CAN								
VW Polo Bluemotion Please order separately extension for socket holder, order no. 921740650001. Please check if there is a towing capacity in the car documents.	04/14-	KIT		321 878 900 113			120	18.5	7.0	50	1200		included in the KIT	-04/14	S	CAN	C	E	D1	L1	V	105	L	
VW Polo Classic Saloon	96-03			344 025 600 001	→		90	17.0	6.7	70	1200		300 060 300 107	10/99-	--	C2	--	E1	--	--	H	45	B	
													300 060 300 113	10/99-	--	C2	--	E1	D1	L1	H	45	B	
VW Polo Cross Please order cover for bumper cutout at VW dealers.	02/06-06/09			321 523 600 001			90	16.0	7.0	50	1200		321 524 300 113		S	C2	C	E	D1	L1	H	45	B	
		KIT		321 523 900 113			90	18.0	7.0	50	1200		included in the KIT		S	C2	C	E	D1	L1	H	45	B	
VW Polo Cross	02/06-06/09			321 607 600 001			75	16.0	7.0	50	1200		321 524 300 107		S	C2	C	E	--	--	H	45	B	
													321 524 300 113		S	C2	C	E	D1	L1	H	45	B	
		KIT		321 607 900 113			75	18.0	7.0	50	1200		included in the KIT		S	C2	C	E	D1	L1	H	45	B	
VW Polo Cross	06/09-04/14			321 741 600 001	→		120	15.0	7.0	85	1200		321 527 300 107	-04/14	S	CAN	C	E	--	--	V	105	L	
													321 527 300 113	-04/14	S	CAN	C	E	D1	L1	V	105	L	
					321 832 600 001			120	14.5	7.0	50	1200		321 527 300 143		S								R
		KIT		321 741 900 113			120	17.0	7.0	85	1200		included in the KIT	-04/14	S	CAN	C	E	D1	L1	V	105	L	









VW Polo Cross Please order spoiler at VW dealers.	06/09-04/14			321 748 600 001	→ 	120	16.5	7.0	85	1200		321 527 300 107	-04/14	S	CAN	C	E	--	--	V	105	L
				321 878 600 001		120	16.5	7.0	50	1200		321 527 300 113	-04/14	S	CAN	C	E	D1	L1	V	105	L
												321 527 300 143		S								
		KIT		321 748 900 113		120	18.5	7.0	85	1200	included in the KIT	-04/14	S	CAN	C	E	D1	L1	V	105	L	
		KIT		321 748 900 143		120	18.5	7.0	85	1200												
VW Polo Fun It is possible to receive a permission for the assembly of a towbar from VW.	04-09			321 607 600 001		75	16.0	7.0	50	1200		321 524 300 113		S	C2	C	E	D1	L1	H	45	B
				321 523 600 001		90	16.0	7.0	50	1200												
		KIT		321 607 900 113		75	18.0	7.0	50	1200	included in the KIT		S	C2	C	E	D1	L1	H	45	B	
		KIT		321 523 900 113		90	18.0	7.0	50	1200												
		VW Polo Gti	06/09-04/14			321 741 600 001	→ 	120	15.0	7.0	85	1200		321 527 300 107	-04/14	S	CAN	C	E	--	--	V
	321 832 600 001					120	14.5	7.0	50	1200	321 527 300 113	-04/14		S	CAN	C	E	D1	L1	V	105	L
											321 527 300 143			S								
KIT				321 741 900 113		120	17.0	7.0	85	1200	included in the KIT	-04/14	S	CAN	C	E	D1	L1	V	105	L	
KIT				321 741 900 143		120	17.0	7.0	85	1200												

Volkswagen

















VW Polo Gti Please order cover for bumper cutout at VW dealers.	06/09-04/14		321 748 600 001			120	16.5	7.0	85	1200		321 527 300 107	-04/14	S	CAN	C	E	--	--	V	105	L	
			321 878 600 001				120	16.5	7.0	50		1200	321 527 300 113	-04/14	S	CAN	C	E	D1	L1	V	105	L
			321 527 300 143												S								
	KIT		321 748 900 113		120	18.5	7.0	85	1200	included in the KIT	-04/14	S	CAN	C	E	D1	L1	V	105	L			
	KIT		321 748 900 143		120	18.5	7.0	85	1200														
VW Polo Gti	04/14-	KIT		321 832 900 113		120	16.5	7.0	50	1200	included in the KIT	04/14-	S	CAN									
VW Polo Gti Please order cover for bumper cutout at VW dealers.	04/14-	KIT		321 878 900 113		120	18.5	7.0	50	1200	included in the KIT	04/14-	S	CAN									
VW Polo Hatchback	11/99-10/01			321 510 600 001		90	14.8	5.2	50	800	300 072 300 107		--	FRE	--	--	--	--	V			B	
											300 072 300 113		--	FRE	--	--	D1	L1	V			B	
VW Polo Hatchback for Polo Fun with permission for the assembly of a towbar by VW exc. GTi / 150 HP inc. facelift from 05/05, Blue Motion Please order the following parts for the bumper cover at VW dealers': 1 spoiler 6Q6 807 433 B41 1 cover 6Q6 807 397 B41 2 bolt 6Q6 807 643 2 spring cotters 6Q6 807 180 2 washers 6N0 129 355	11/01-09		321 523 600 001		90	16.0	7.0	50	1200		321 523 300 107	-05/05	S	C2	C	E	--	--	H	45	B		
			321 523 300 113								-05/05	S	C2	C	E	D1	L1	H	45	B			
			321 524 300 113								05/05-	S	C2	C	E	D1	L1	H	45	B			
VW Polo Hatchback for Polo Fun with permission for the assembly of a towbar by VW, exc. GTi / 150 HP, inc. facelift from 05/05, inc. Blue Motion (a different cutout is necessary)	11/01-09		321 607 600 001		75	16.0	7.0	50	1200		321 523 300 107	-05/05	S	C2	C	E	--	--	H	45	B		
			321 523 300 113								-05/05	S	C2	C	E	D1	L1	H	45	B			
			321 524 300 113								05/05-	S	C2	C	E	D1	L1	H	45	B			





Volkswagen

VW Sharan	09/10-			321 698 600 001		22.0	12.3	100	2500		321 600 300 107			S	CAN	C	E	--	--	V	105	L
											321 600 300 113			S	CAN	C	E	D	L1	V	105	L
											321 600 300 153			S	CAN	C	E	D	L1	V	105	R
		KIT		321 698 900 113		24.0	12.3	100	2500		included in the KIT			S	CAN	C	E	D	L1	V	105	L
VW Sharan Please order separately Spoiler and cover for bumper cutout at VW dealer's.	09/10-			321 700 600 001		22.0	12.3	100	2500		321 600 300 107			S	CAN	C	E	--	--	V	105	L
											321 600 300 113			S	CAN	C	E	D	L1	V	105	L
											321 600 300 153			S	CAN	C	E	D	L1	V	105	R
		KIT		321 700 900 113		24.0	12.3	100	2500		included in the KIT			S	CAN	C	E	D	L1	V	105	L
VW Sharan Please order separately Spoiler and cover for bumper cutout at VW dealer's. for right-hand-drive vehicles	09/10-	KIT		321 700 900 153		24.0	12.3	100	2500		included in the KIT			S	CAN	C	E	D	L1	V	105	R
VW Tiguan	11/07-			305 421 600 001		90	19.0	12.6	100	2500	321 600 300 107			S	CAN	C	E	--	--	V	105	L
				305 423 600 001		90	21.0	12.6	100	2500	321 600 300 113			S	CAN	C	E	D	L1	V	105	L
		KIT		321 727 900 113		90	21.0	12.0	140	2500	included in the KIT			S	CAN	C	E	D	L1	V	105	L
		KIT		321 728 900 113		90	23.0	12.0	140	2500				S	CAN	C	E	D	L1	V	105	L
VW Tiguan for right-hand-drive vehicles	11/07-	KIT		321 727 900 153		90	21.0	12.0	140	2500	included in the KIT			S	CAN	C	E	D	L1	V	105	R
		KIT		321 728 900 153		90	23.0	12.0	140	2500				S	CAN	C	E	D	L1	V	105	R

VW Touareg inc. models 04/10- exc. vehicles with spare wheel on tailgate To guarantee an optimal appearance of the vehicle it is necessary to order the rear lower spoiler and the cover (depending on the equipment of the vehicle) separately from the VW dealer (see original VW catalogue ETKA, table 806-50). For vehicles -04/10 please order separately foam support at VW dealers.	11/02-			321 735 600 001		150	33.5	16.4	140	3500		321 500 300 113	-04/10	S	CAN	--	E	D	L1	H	45	B
				321 736 600 001		150	34.0	16.4	140	3500		321 765 300 107	04/10-08/14 exc. vehicles with ACC / distance control	S	CAN	C	E	D	L1	V	180	B
												321 765 300 113	04/10-08/14 exc. vehicles with ACC / distance control	S	CAN	C	E	D	L1	V	180	B
												321 766 300 113	08/14-	S	CAN	C	E	D	L	H		
VW Touareg inc. models 04/10- exc. vehicles with spare wheel on tailgate To guarantee an optimal appearance of the vehicle it is necessary to order the rear lower spoiler and the cover (depending on the equipment of the vehicle) separately from the VW dealer (see original VW catalogue ETKA, table 806-50). For vehicles -04/10 please order separately foam support at VW dealers.	11/02-04/10	KIT		321 500 900 113		150	36.0	16.4	140	3500		included in the KIT	-04/10	S	CAN	--	E	D	L1	H	45	B
VW Touareg inc. models 04/10- exc. vehicles with spare wheel on tailgate To guarantee an optimal appearance of the vehicle it is necessary to order the rear lower spoiler and the cover (depending on the equipment of the vehicle) separately from the VW dealer (see original VW catalogue ETKA, table 806-50). For vehicles -04/10 please order separately foam support at VW dealers.	04/10-08/14	KIT		321 736 900 113		150	36.0	16.4	140	3500		included in the KIT	04/10-08/14 exc. vehicles with ACC / distance control	S	CAN	C	E	D	L1	V	180	B

Volkswagen



VW Touareg inc. models 04/10- exc. vehicles with spare wheel on tailgate To guarantee an optimal appearance of the vehicle it is necessary to order the rear lower spoiler and the cover (depending on the equipment of the vehicle) separately from the VW dealer (see original VW catalogue ETKA, table 806-50). For vehicles -04/10 please order separately foam support at VW dealers.	08/14-	KIT		321 766 900 113			36.0	16.4	140	3500			included in the KIT	08/14-	S	CAN	C	E	D	L	H		B
VW Touran inc. Cross-Touran	03/03-			321 536 600 001		90	19.5	9.9	75	1800		321 600 300 107		S	CAN	C	E	--	--	V	105	L	
												321 600 300 113		S	CAN	C	E	D	L1	V	105	L	
VW Touran inc. Cross-Touran 08/10-: Please order separately cover for bumper cutout at VW dealer's.	03/03-	KIT		321 536 900 113		90	21.5	9.9	75	1800		included in the KIT		S	CAN	C	E	D	L1	V	105	L	
															S	CAN	C	E	D	L1	V	105	R
VW Touran inc. Cross-Touran 08/10-: Please order separately cover for bumper cutout at VW dealer's.	03/03-			321 838 600 001		90	20.0	9.9	75	1800		321 600 300 107		S	CAN	C	E	--	--	V	105	L	
												321 600 300 113		S	CAN	C	E	D	L1	V	105	L	
VW Touran inc. Cross-Touran 08/10-: Please order separately cover for bumper cutout at VW dealer's. for right-hand-drive vehicles	03/03-	KIT		321 838 900 113		90	22.0	9.9	75	1800		included in the KIT		S	CAN	C	E	D	L1	V	105	L	
															S	CAN	C	E	D	L1	V	105	R
VW Touran inc. Cross-Touran 08/10-: Please order separately cover for bumper cutout at VW dealer's. for right-hand-drive vehicles	03/03-	KIT		321 838 900 153		90	22.0	9.9	75	1800		included in the KIT		S	CAN	C	E	D	L1	V	105	R	
VW Touran inc. Cross-Touran	03/03-	KIT		321 536 900 153		90	21.5	9.9	75	1800		included in the KIT		S	CAN	C	E	D	L1	V	105	R	
VW Transporter T4 Van inc. Syncro	09/90-01/96			321 358 600 001		90	16.5	13.4	100	2600		321 315 300 107	-08/98	S	C2	--	E1	--	--	H	30	L	
												321 315 300 113	-08/98	S	C2	--	E1	D1	L1	H	30	L	

VW Transporter T4 Van inc. Syncro and Caravelle	01/96-07/03		321 391 600 001			90	20.2	13.4	105	2600		321 315 300 107	-08/98	S	C2	--	E1	--	--	H	30	L	
												321 315 300 113	-08/98	S	C2	--	E1	D1	L1	H	30	L	
												321 316 300 107	09/98-	S	C2	--	E1	--	--	H	30	L	
												321 316 300 113	09/98-	S	C2	--	E1	D1	L1	H	30	L	
VW Transporter T4 Van inc. Syncro and Caravelle bracket for towball: 921405631005	01/96-07/03		321 405 600 001			90	21.0	13.4	100	2600		321 315 300 107	-08/98	S	C2	--	E1	--	--	H	30	L	
												321 315 300 113	-08/98	S	C2	--	E1	D1	L1	H	30	L	
												321 316 300 107	09/98-	S	C2	--	E1	--	--	H	30	L	
												321 316 300 113	09/98-	S	C2	--	E1	D1	L1	H	30	L	
VW Transporter T4 Van inc. Syncro and Caravelle	09/98-07/03	KIT		321 391 900 113			90	22.2	13.4	105	2600		included in the KIT	09/98-	S	C2	--	E1	D1	L1	H	30	L
VW Transporter T4 Chassis Cab inc. Syncro	09/90-03		321 316 600 001			90	26.4	13.7	105	2600		300 052 300 107	09/98-	--	FRE	--	E1	--	--	V		B	
												300 052 300 113	09/98-	--	FRE	--	E1	D1	--	V		B	
												300 060 300 107	-08/98	--	C2	--	E1	--	--	H	45	B	
												300 060 300 113	-08/98	--	C2	--	E1	D1	L1	H	45	B	
VW Transporter T4 Chassis Cab low-load flatbed, inc. Syncro	09/90-03		321 317 600 001	→		90	26.5	13.7	105	2600		300 052 300 107	09/98-	--	FRE	--	E1	--	--	V		B	
												300 052 300 113	09/98-	--	FRE	--	E1	D1	--	V		B	
												300 060 300 107	-08/98	--	C2	--	E1	--	--	H	45	B	
												300 060 300 113	-08/98	--	C2	--	E1	D1	L1	H	45	B	





Volkswagen





















VW Transporter T5 Van inc. 4 Motion, exc. Rockton To guarantee an optimal fit of the bumper it is necessary to mount 2 foam carriers, please order from VW-dealer, order no. 7H0 807 252 A Van (without back side windows) 10/09-: To guarantee an optimal fit of the bumper it is necessary to mount: 1 x plastic rail 7H0 807 723 8 x gasket 357 853 586 B 8 x clip 701 867 299	03-		321 650 600 001	115	20.0	14.0	100	2800	321 025 300 113	additional cable for continuous plus (Please order additionally.)	--	--	--	E1	D	L	V		L
			321 681 600 001	120	20.0	14.0	100	2800	321 451 300 100	additional wire trailer stability system It is possible to activate trailer stability system starting from the following chassis numbers: WV2ZZZ7HZ5X0139 and WV2ZZZ7HZ5H0597	S	--	--	E	--	--	V	60	B
			321 451 300 107	-10/09	S	C2	C	E	--	--	H	45	L						
			321 451 300 113	-10/09	S	C2	C	E	D1	L1	H	45	L						
			321 451 300 147	-10/09	S	C2	C	E1	--	--	H	45	R						
			321 453 300 107	-10/09	S	C2	C	E1	--	--	H	45	L						
			321 454 300 107	10/09-	S	CAN	C	E	--	--	V	180	L						
			321 454 300 113	10/09-	S	CAN	C	E	D	L1	V	180	L						
			321 455 300 001	10/09- extension kit for vehicles without fuse box under the drivers seat	S					D	V	60	B						
			321 650 300 113	07/11-05/12 for vehicles with preparation	S	CAN	--	E	D	L1	H	30	B						
321 652 300 113	05/12- for vehicles with preparation	S	CAN	--	E	D	L1	H	30	B									























VW Transporter T5 Van inc. 4 Motion, exc. Rockton To guarantee an optimal fit of the bumper it is necessary to mount 2 foam carriers, please order from VW-dealer, order no. 7H0 807 252 A Van (without back side windows) 10/09-: To guarantee an optimal fit of the bumper it is necessary to mount: 1 x plastic rail 7H0 807 723 8 x gasket 357 853 586 B 8 x clip 701 867 299	03-		321 651 600 001				120	20.0	14.0	100	2800		321 025 300 113	additional cable for continuous plus (Please order additionally.)	--	--	--	E1	D	L	V		L
													321 451 300 100	additional wire trailer stability system It is possible to activate trailer stability system starting from the following chassis numbers: WV2ZZZ7HZ5X0139 and WV2ZZZ7HZ5H0597	S	--	--	E	--	--	V	60	B
													321 451 300 107	-10/09	S	C2	C	E	--	--	H	45	L
													321 451 300 113	-10/09	S	C2	C	E	D1	L1	H	45	L
													321 451 300 147	-10/09	S	C2	C	E1	--	--	H	45	R
													321 453 300 107	-10/09	S	C2	C	E1	--	--	H	45	L
													321 454 300 107	10/09-	S	CAN	C	E	--	--	V	180	L
													321 454 300 113	10/09-	S	CAN	C	E	D	L1	V	180	L
													321 455 300 001	10/09- extension kit for vehicles without fuse box under the drivers seat	S					D	V	60	B
													321 650 300 113	07/11-05/12 for vehicles with preparation	S	CAN	--	E	D	L1	H	30	B
321 652 300 113	05/12- for vehicles with preparation	S	CAN	--	E	D	L1	H	30	B													

VW Transporter T5 Chassis Cab high-load flatbed	03-			321 538 600 001			90	26.4	13.8	105	2500		321 452 300 107	-10/09	S	C2	C	E1	--	--	H	45	L
													321 452 300 113	-10/09	S	C2	C	E1	--	--	H	45	L
													321 454 300 107	10/09-	S	CAN	C	E	--	--	V	180	L
													321 454 300 113	10/09-	S	CAN	C	E	D	L1	V	180	L
													321 455 300 001	10/09- extension kit for vehicles without fuse box under the drivers seat	S				D		V	60	B
													321 651 300 113	07/11-05/12 for vehicles with preparation	S	CAN	--	E	D	--	H	15	B
													321 653 300 113	05/12- for vehicles with preparation	S	CAN	C	E	D	L			B
VW Transporter T5 Chassis Cab low-load flatbed	03-			321 601 600 001			90	26.4	13.8	100	2500		321 452 300 107	-10/09	S	C2	C	E1	--	--	H	45	L
													321 452 300 113	-10/09	S	C2	C	E1	--	--	H	45	L
													321 454 300 107	10/09-	S	CAN	C	E	--	--	V	180	L
													321 454 300 113	10/09-	S	CAN	C	E	D	L1	V	180	L
													321 455 300 001	10/09- extension kit for vehicles without fuse box under the drivers seat	S				D		V	60	B
													321 651 300 113	07/11-05/12 for vehicles with preparation	S	CAN	--	E	D	--	H	15	B
													321 653 300 113	05/12- for vehicles with preparation	S	CAN	C	E	D	L			B



























Volkswagen

























VW Transporter T5 Chassis Cab towball 329076600001 inc. swap system or automatic bolt coupling permitted	03-		321 739 600 001			>60	28.0	13.7	100	2500		321 452 300 107	-10/09	S	C2	C	E1	--	--	H	45	L	
												321 452 300 113	-10/09	S	C2	C	E1	--	--	H	45	L	
												321 454 300 107	10/09-	S	CAN	C	E	--	--	V	180	L	
												321 454 300 113	10/09-	S	CAN	C	E	D	L1	V	180	L	
												321 455 300 001	10/09- extension kit for vehicles without fuse box under the drivers seat	S				D		V	60	B	
												321 651 300 113	07/11-05/12 for vehicles with preparation	S	CAN	--	E	D	--	H	15	B	
			321 653 300 113											S	CAN	C	E	D	L			B	
VW Transporter T6 Van	05/15-		321 650 600 001			115	20.0	14.0	100	2800													
			321 651 600 001			120	20.0	14.0	100	2800													
VW Transporter T6 Chassis Cab	05/15-		321 538 600 001			90	26.4	13.8	105	2500													
VW Up This towbar can only be used in combination with load carriers/ cycle carriers! This vehicle is not homologated for towing trailers.	11-		350 044 600 001				15.0		50			321 044 300 113		S	CAN		E	--	--	V	120	B	

Volvo 850 Saloon and Estate exc. 4 WD, exc. vehicles with tow-hook on the longitudinal beam right side (from model '92)	93-		320 041 600 001	→		150	23.6	9.7	75	1900		300 210 300 107							--	A	--	--	--	--	V		B						
																															--	A	--
Volvo C30	12/06-13		320 065 600 001		180	12.0	8.9	100	1600		320 240 300 107								S	CAN	--	E2	--	--	H	60	B						
					320 066 600 001	180	14.5	8.9	100		1600								320 240 300 113	S	CAN	--	E2	D	L1	H	60	B					
		KIT KIT		320 065 900 113		180	14.0	8.9	100	1600	included in the KIT										S	CAN	--	E2	D	L1	H	60	B				
				320 066 900 113		180	16.5	8.9	100	1600																							
Volvo C70 / S70 / V70 exc. 4 WD, from '99 an exhaust bracket must be mounted additionally (order no. 920040631001) C70: -05/06	02/97-03/00		320 041 600 001	→		150	23.6	9.7	75	1900		300 210 300 107							--	A	--	--	--	--	V		B						
																															--	A	--
Volvo S40 / V40	04/96-01/04		320 093 600 001			21.0	8.2	80	1500		300 072 300 107	-06/00	--	FRE	--	--	--	--	V		B												
																									--	FRE	--	--	D1	L1	V		B
																										--	A	--	--	--	V		B
																											--	A	--	E1	D1	L1	V
Volvo S40 / V50 exc. Sports, exc. R design	02/04-		320 059 600 001		40	9.7	8.9	100	1600		320 051 300 113	→	-05/07 for V50	S	FRE	--	E2	D	--	H	60	B											
					320 060 600 001	40	10.0	8.9	100		1600	320 058 300 113	-05/07 for S40	S	FRE	--	E2	D	L1	H	60	B											
		KIT KIT		320 059 900 113		40	11.7	8.9	100	1600	included in the KIT																						
				320 060 900 113		40	12.0	8.9	100	1600																							
Volvo S40 / V50 exc. Sports, exc. R design	06/07-	KIT KIT		320 059 900 113		40	11.7	8.9	100	1600	included in the KIT																						
			320 060 900 113		40	12.0	8.9	100	1600																								

Volvo V40 inc. XC40 / V40 Cross Country	09/12-			320 107 600 001		90	15.0	8.7	75	1500		320 108 300 107			S	A	--	E2	--	--	H	60	B
				320 108 600 001		90	18.0	8.7	75	1500		320 108 300 113			S	A	--	E2	D	L1	H	60	B
		KIT		320 107 900 113		90	17.0	8.7	75	1500		included in the KIT			S	A	--	E2	D	L1	H	60	B
		KIT		320 108 900 113		90	20.0	8.7	75	1500						S	A	--	E2	D	L1	H	60
Volvo V60	11/10-			320 071 600 001		90	15.0	10.2	80	1800		320 543 300 107			S	CAN	--	E2	--	--	H	45	B
				320 072 600 001		90	17.0	10.2	80	1800		320 543 300 113			S	CAN	--	E2	D1	L1	H	45	B
		KIT		320 071 900 113		90	17.0	10.2	80	1800		included in the KIT			S	CAN	--	E2	D1	L1	H	45	B
		KIT		320 072 900 113		90	19.0	10.2	80	1800						S	CAN	--	E2	D1	L1	H	45
Volvo V70 exc. 4 WD	03/00-09/07			320 050 600 001		150	25.0	10.3	100	2000		320 049 300 113	-09/04	S	FRE	C	E	D	L	H	45	B	
												320 540 300 113	10/04-	S	FRE	--	E2	D	L1	H	45	B	
Volvo V70 with height control exc. 4 WD	03/00-09/07			320 053 600 001		150	25.0	10.3	120	2000		320 049 300 113	-09/04	S	FRE	C	E	D	L	H	45	B	
												320 540 300 113	10/04-	S	FRE	--	E2	D	L1	H	45	B	
Volvo V70 inc. AWD exc. XC70	03/00-09/07			320 090 600 001		100	21.0	10.3	80	2000		320 049 300 113	-09/04	S	FRE	C	E	D	L	H	45	B	
												320 540 300 113	10/04-	S	FRE	--	E2	D	L1	H	45	B	















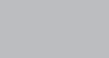

































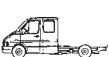
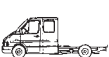

Volvo

Volvo V70 without height control inc. AWD	09/07-		320 069 600 001		90	20.0	11.0	85	2100	320 543 300 107			S	CAN	--	E2	--	--	H	45	B
			320 075 600 001		60	22.0	11.0	85	2100	320 543 300 113			S	CAN	--	E2	D1	L1	H	45	B
	KIT		320 069 900 113		90	22.0	11.0	85	2100	included in the KIT			S	CAN	--	E2	D1	L1	H	45	B
	KIT		320 075 900 113		60	24.0	11.0	85	2100				S	CAN	--	E2	D1	L1	H	45	B
Volvo V70 with height control inc. AWD	09/07-		320 073 600 001		90	20.0	11.0	85	2100	320 543 300 107			S	CAN	--	E2	--	--	H	45	B
			320 076 600 001		60	24.0	11.0	85	2100	320 543 300 113			S	CAN	--	E2	D1	L1	H	45	B
	KIT		320 073 900 113		90	22.0	11.0	85	2100	included in the KIT			S	CAN	--	E2	D1	L1	H	45	B
	KIT		320 076 900 113		60	24.0	11.0	85	2100				S	CAN	--	E2	D1	L1	H	45	B
Volvo XC60	11/08-		320 063 600 001		90	21.0	11.0	90	2000	320 543 300 107			S	CAN	--	E2	--	--	H	45	B
			320 115 600 001		90	24.0	11.0	90	2000	320 543 300 113			S	CAN	--	E2	D1	L1	H	45	B
	KIT		320 063 900 113		90	23.0	11.0	90	2000	included in the KIT			S	CAN	--	E2	D1	L1	H	45	B
	KIT		320 064 900 113		90	26.0	11.0	90	2000				S	CAN	--	E2	D1	L1	H	45	B
Volvo XC70	03/00-09/07		320 086 600 001		100	17.0	10.3	80	2000	320 049 300 113	-09/04		S	FRE	C	E	D	L	H	45	B
			320 097 600 001		100	26.0	10.3	80	2000	320 540 300 113	10/04-		S	FRE	--	E2	D	L1	H	45	B

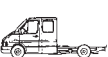
Volvo XC70 without height control	09/07-			320 073 600 001		90	20.0	11.0	85	2100		320 543 300 107			S	CAN	--	E2	--	--	H	45	B
				320 076 600 001		60	24.0	111.0	85	2100		320 543 300 113			S	CAN	--	E2	D1	L1	H	45	B
	KIT		320 073 900 113		90	22.0	11.0	85	2100		included in the KIT			S	CAN	--	E2	D1	L1	H	45	B	
	KIT		320 076 900 113		60	24.0	11.0	85	2100					S	CAN	--	E2	D1	L1	H	45	B	
Volvo XC70 with height control	09/07-			320 095 600 001		90	20.0	11.0	85	2100		320 543 300 107			S	CAN	--	E2	--	--	H	45	B
				320 092 600 001		90	20.0	11.0	80	2100		320 543 300 113			S	CAN	--	E2	D1	L1	H	45	B
	KIT		320 095 900 113		90	22.0	11.0	85	2100		included in the KIT			S	CAN	--	E2	D1	L1	H	45	B	
	KIT		320 092 900 113		90	22.0	11.0	80	2100					S	CAN	--	E2	D1	L1	H	45	B	
Volvo XC90	01/03-			320 098 600 001		120	21.0	12.2	90	2250		320 049 300 113	-09/04		S	FRE	C	E	D	L	H	45	B
				320 057 600 001		120	26.2	12.2	140	2250		320 780 300 113	09/04-		S	FRE	--	E2	D	L1	H	60	B
Volvo XC90 KIT = towbar inc. electrical kit 13 pins	10/04-04/15	KIT		320 057 900 113		120	28.2	12.2	140	2250		included in the KIT	09/04-		S	FRE	--	E2	D	L1	H	60	B
Volvo XC90	04/15-			320 101 600 001																			
				320 102 600 001																			

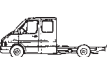
Towing brackets, couplings and special towbars

Mercedes-Benz Sprinter / Volkswagen LT 2

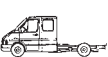
max. total weight	2,8t (2,95t)		3,5t			4,0t and 4,6t		6,0t	6,0t
wheelbase	3.000 mm	3.550 mm	3.000 mm	3.550 mm	4.025 mm	3.550 mm	4.025 mm	3.550 mm	4.025 mm
Van	1 	2 	1 	2 		2 			
Van with high top		2 		2 	2 	4 	8 		
Minibus	1 	2 	1 	2 					
Minibus with high top		2 		2 	2 				
Flatbed	3 	3 	3 	3 	3 	6 	5 	9 	9 
Flatbed with dual cab		3 		3 	3 	6 	5 	9 	9 
Chassis with cab	3 	3 	3 	3 	3 	6 	7 	9 	9 
Chassis with dual cab		3 		3 	3 	6 	5 	9 	9 
Tipper			3 	3 		6 			
Tipper with dual cab				3 		6 			

MB Sprinter / VW LT II 03/96-03/06

Ident-no.	towing capacity 2000 kg end of no.: ...600001	towing capacity 2800/3000 kg end of no.: ...600001	ball plate for 4 WD end of no.: ...600001
1	313087+329059	313152+329059	329042600001
2	313088+329059	313149+329059	329042600001
3	313118 (discontinued, repl. 313157) +329059 ball 40 mm deeper: 313118+329062	313153+329059 ball 40 mm deeper: 313153+329062	329042600001
4	313103 (discontinued, repl. 313154) +329062	repl.: 313154+329062	329042600001
5	313105*+329062	313156*+329062	329042600001
6	313107*+329062	313157*+329062	329042600001
7	313105*+329062+313112605001	313156*+329062+313112605001	329042600001
8	313088+329062	313155+329062	329042600001
9		313145+329062 (3500 kg)	

Product range of MB Sprinter / VW LT II 03/96-03/06

MB Sprinter / VW LT 2	order no.: ...600001	D-Value		vertical load	towing capacity	mounting time	
van/minibus, 3,5t max.total weight, wheelbase=3000 mm	313087 discontinued, repl.: 313152	13,7		100	2000	90	
van/minibus, 3,5t max.total weight, wheelbase=3550/4025 mm	313088 discontinued, repl.: 313149	13,7		100	2000	90	
van / minibus, 4,0 and 4,6t max.total weight, wheelbase=3550mm	313103 discontinued, repl.: 313154	13,7		100	2000	90	
chassis with cab / dual cab, 4,0 and 4,6t max.total weight, wheelbase=4025 mm	313105* discontinued	13,7		100	2000	120	
chassis with cab / dual cab, 4,0 and 4,6t max.total weight, wheelbase=3550mm	313107* discontinued	13,7		100	2000	120	
chassis with cab / dual cab 3,5t max.total weight	313118 discontinued, repl.: 313153	13,7		100	2000	90	
board step for box and estate	313132						
van / minibus, 3,5t max.total weight, wheelbase=3550/4025mm	313149	17,82		120	2800	150	
van / minibus, 3,5t max.total weight, wheelbase=3000 mm	313152 discontinued	17,82		120	2800	150	
chassis with cab / dual cab 3,5t max.total weight	313153	17,82		120	2800	150	
van / minibus, 4,0 and 4,6t max.total weight, wheelbase=3550mm	313154 discontinued	17,82		120	3000	150	
chassis with cab / dual cab, 4,0 and 4,6t max.total weight, wheelbase=4025mm	313155 discontinued	17,82		120	3000	150	
chassis with cab / dual cab 4,0 and 4,6t max.tatal weight, wheelbase=4025mm	313156* discontinued	17,82		120	3000	>150	
chassis with cab / dual cab, 4,0 and 4,6t max.total weight, wheelbase 3550mm	313157* discontinued	17,82		120	3000	>150	
chassis with cab / dual cab 6,0t max.total weight, not for dumper	313145 discontinued	22,0		150	3500		
towball	329042	17,2		120			
towball	329059	23,5		150			
towball	329062	19,0		120			
swap system for all models	329064600001	18,5		120			
electrical kit, 7-poles, all models until 12/99 van / minibus from 01/00 platform from 01/00	313101300107 313103300107 (discontinued) 300052300107	S	C2	E	-	V	
		S	C2	E	-	V	
		-	FRE	-	-	V	
electrical kit, 13-poles, all models until 12/99 van / minibus from 01/00 flatbed from 01/00	313101300113 313103300113 300052300113	S	C2	E	-	V	
		S	C2	E	D	V	
		-	FRE	-	D1	V	

The board step 313132600001 must be used for all vans/minibuses. The originally mounted board step cannot be used for all vans/minibuses. This is also intended for van version with integrated step device in the bumper. Your Mercedes or VW dealer will be of help in case you need further information with regard to the towing capacity of your vehicle.

- * When mounting the towbar the integral under run guard can no longer be used on the vehicle. Please order a new under run guard at the Mercedes or VW dealer:
 MB-order no.: for flatbed / van 904 520 0333, for dumper 904 520 0733
 for flatbed 6,0 t max. total weight 905 520 0133 (313145)
 VW-order no.: for flatbed / van 2D3 804 490 N, for dumper 2D3 804 490 Q

Universal HGV towing brackets

Please pay attention to the D-value of each component!



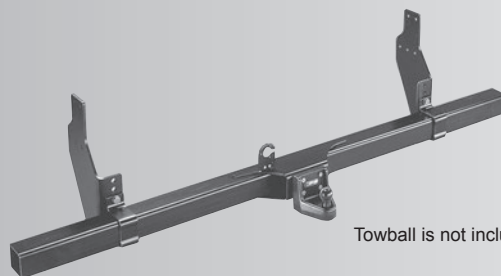

Towing bracket

with integral anderrun guard
order no. 313404600001
and towball
order no. 329103600001



under run guard
approval no.: e13-6131

Towball is not included.

	order no.		D-value kN				
Towing bracket with integral anderrun guard for HGV. Swap system permitted.	313404600001	69,0	25,1	150	3000 3500	17000 9400	
towball recommended	329103600001	8,2	25,1	120	3000 3500	17000 9400	





Towing bracket

with integral anderrun guard
order no. 342179600001
and towball
order no. 329103600001



under run guard
approval no.: e13-6130

Towball is not included.



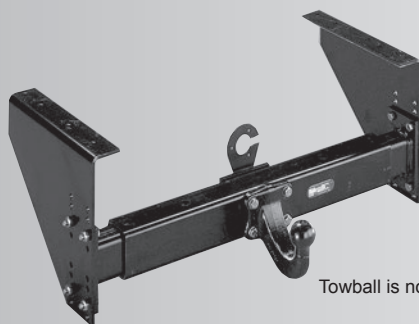

	order no.		D-value kN				
Towing bracket with integral anderrun guard for HGV. Swap system permitted.	342179600001	76,0	23,5	150	3500	z.B. 7500	
towball recommended	329103600001	8,2	25,1	120			

Towing bracket

with integral anderrun guard
order no. 314052600001
and towball
order no. 329062600001



Towball is not included.

	order no.		D-value kN				
Towing bracket for HGV Swap system permitted.	314052600001	27,2	16,4	100	2000	10000	
towball recommended	329062600001						

Universal HGV- electrical kits for 12V	order no.	car specific	flash control	coding	PDCcut off	perma- nent plus	charging line	electrical connec- tion	moun- ting time	
	300201300113	-	A	-	-	D1	L1	V		

Technical data for universal HGV towbars

all measurements in mm

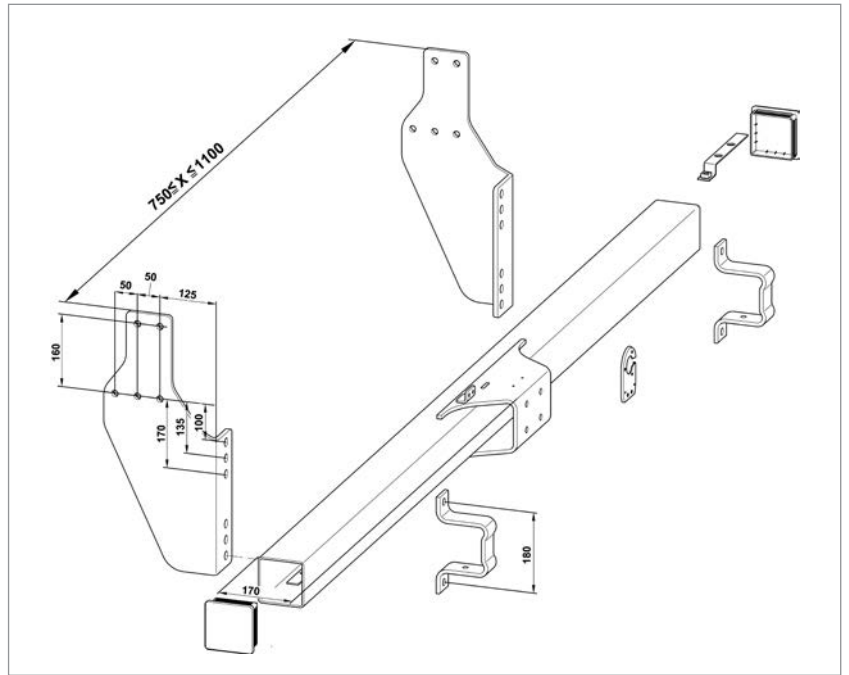

342 179

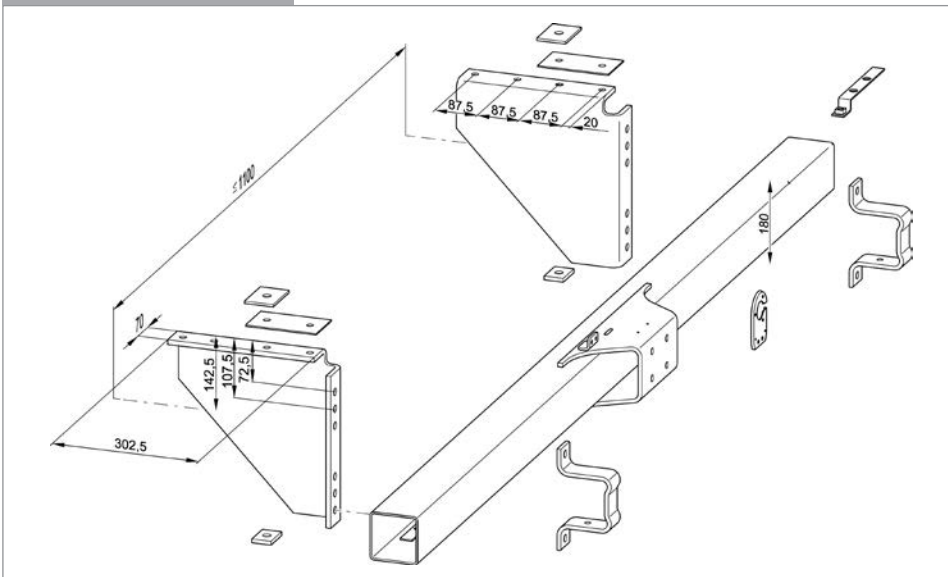





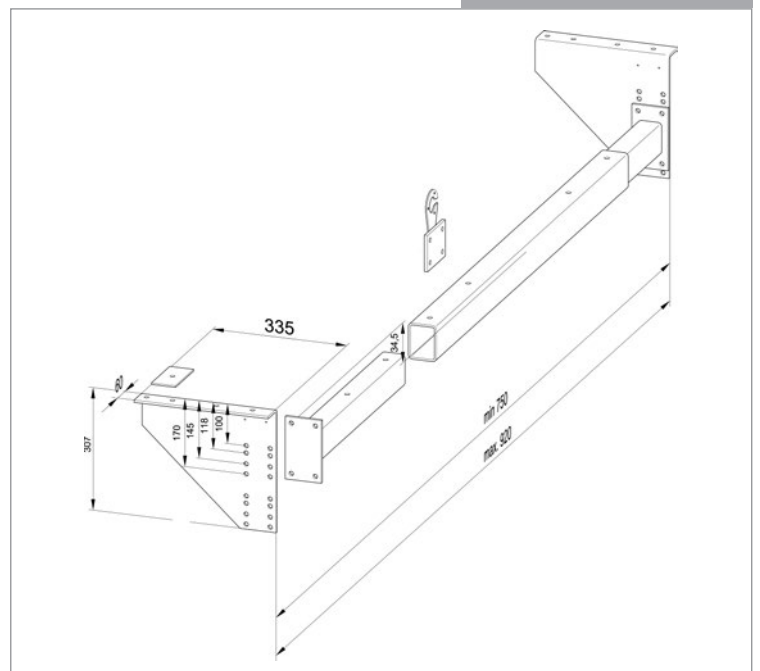



313 404

314 052

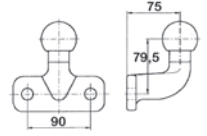
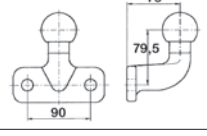
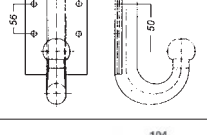
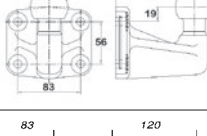

Towing brackets universally applicable due to 2-dimensional adjustment (height and width)

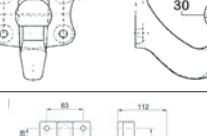
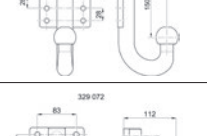
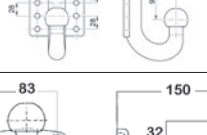
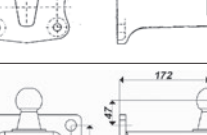
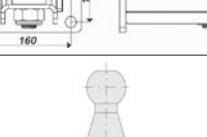
Towballs and Couplings for HGV and Off-Road Vehicles

	order no.		D-Value			kg 	
	329076600001	2,4	17,0	150	2.500 or 2.200 or 2.000	5.600 or 8.100 or 11.500	
	incl. 2 screws M 16 x 50, 8.8						
	329080600001	2,4	20,0	150	2.500 or 2.800 or 3.500	11.000 or 7.500 or 4.880	
	incl. 2 screws M 16 x 50, 8.8						
	329042600001	4,4	17,2	100	2.800 or 2.500 or 2.000	4.700 or 5.800 or 14.200	
	329059600001	3,0	23,5	150	2.800 or 3.100 or 3.500	15.000 or 10.000 or 7.500	
	329103600001	8,5	25,1	120	3.500 or 2.500 or 3.000	9.400 or 40.000 or 17.000	
	329062600001	3,6	23,5	150	2.800 or 3.100 or 3.500	15.000 or 10.000 or 7.500	
	329071600001	4,1	17,5	150	2.500 or 2.800 or 3.500	6.200 or 4.900 or 3.600	
	329072600001	3,7	17,5	150	2.500 or 2.800 or 3.500	6.200 or 4.900 or 3.600	
	329089600001	2,8	17,5	150	2.800 or 2.500 or 3.500	4.900 or 6.200 or 3.600	
	329096600001	13	22,64	120	2.700 or 3.000 or 3.300	15.000 or 10.000 or 7.500	
	incl. 4 screws M 20 x 60, 8.8						
	900008600001	1,05	18,5	150	2.800 or 2.500	5.600 or 7.500	

Mounting parts for Couplings



traverse of the towing vehicle or towing bracket	towball or coupling (order no. ends with ...600001)	screw kit*	
8 - 12 mm	329 042 329 059, 329 062, 329 071, 329 072 329 060, 329 089, 329 103	900 040 632 340 900 045 632 325 900 055 632 552	
15 - 20 mm	329 042, 329 057, 329 062, 329 071, 329 072 329 059 329 060, 329 103	900 050 632 424 900 055 632 552 900 060 632 523	
60 - 65 mm	329 042, 329 062, 329 071, 329 072 329 059 329 060, 329 103, 329 089	900 095 632 553 900 100 632 527 900 105 632 554	
65 - 70 mm	329 042, 329 062, 329 071, 329 072 329 059 329 060, 329 103, 329 089	900 100 632 527 900 105 632 554 900 110 632 505	
70 - 75 mm	329 042, 329 062, 329 071, 329 072 329 059 329 060, 329 103, 329 089	900 105 632 554 900 110 632 505 900 115 632 524	
75 - 80 mm	329 042, 329 062, 329 071, 329 072 329 059 329 060, 329 103, 329 089	900 110 632 505 900 115 632 524 900 120 632 516	
80 - 85 mm	329 042, 329 062, 329 071, 329 072 329 059 329 060, 329 103, 329 089	900 115 632 524 900 120 632 516 900 125 632 504	
85 - 90 mm	329 042, 329 062, 329 071, 329 072 329 059 329 060, 329 103, 329 089	900 120 632 516 900 125 632 504 900 130 632 539	
90 - 95 mm	329 042, 329 062, 329 071, 329 072 329 059 329 060, 329 103, 329 089	900 125 632 504 900 130 632 539 900 135 632 379	

* Each kit contains: 4 screws M10 10.9, 4 nuts, 8 washers.
4th - 6th position of the part no. indicates the length of the screws in mm.

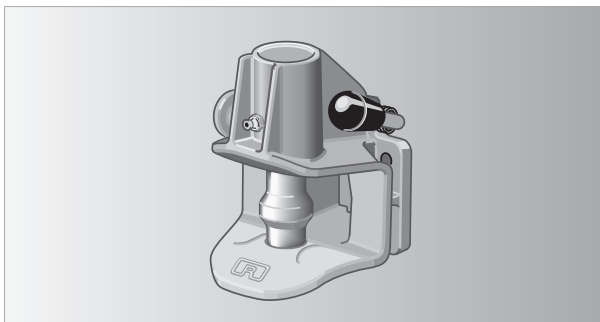
Coupling bolt



Coupling bolt
Rockinger-Nr. 243A11000

order no.	screw-hole circle mm	D-Value kN	Dc-Value kN (depends on the height of the ball)	 kg	 kg	
342090600001	83 x 56	18,0	min. 18,0 max. 30,0	5,0	250	

Swap system

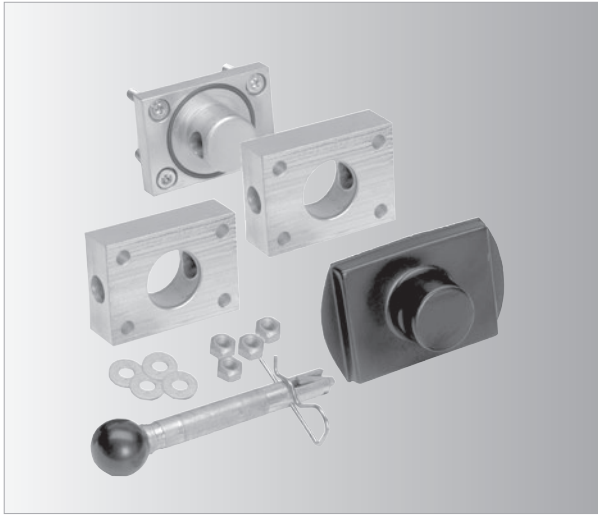

order no.	set	screw-hole circle mm	D/Dc-Value kN	kg	kg
329064600001	1 ground plate 2 exchangeable plates 1 cover	83 x 56	18,5	3,5	120

Application in association with:

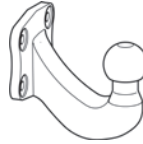

towball

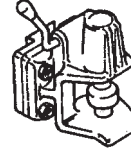

coupling system

*screws / mounting parts (depending on towing brackets and couplings) see following page.

Mounting parts for swap system

screw kit*	Towball or coupling on adapting plate	flange	screws
900 050 636 186	329 042	5 - 10 mm	M 10 x 50
900 055 636 187	329 059, 329 062, 329 072, 329 089 Rockinger-Bolzenkupplung	10 - 15 mm	M 10 x 55
900 060 636 188	329 060, 329 103	15 - 20 mm	M 10 x 60

screw kit*	base plate on towing vehicle or towbar	screws
900 040 636 176	8 - 12 mm	M 10 x 40
900 045 636 177	15 - 20 mm	M 10 x 45
900 090 636 178	60 - 65 mm	M 10 x 90
900 100 636 180	70 - 75 mm	M 10 x 100
900 105 636 181	75 - 80 mm	M 10 x 105
900 110 636 182	80 - 85 mm	M 10 x 110
900 115 636 183	85 - 90 mm	M 10 x 115
900 120 636 184	90 - 95 mm	M 10 x 120
900 130 636 185	95 - 105 mm	M 10 x 130

* Each kit contains

4 screws M10 (10.9)
4 nuts M10
4 washers 10,5

4th - 6th position of the part no. indicates the length of the screws in mm.

Special Couplings



order no.	900 001 005 062
max. total weight kg	3500
vertical load kg	140
D-value kN	20,2
weight kg	3,0

Special Couplings



order no.	329 095 600 001	329 097 600 001
flange plate	130 X 90	130 X 90
hole Ø mm	17	17
diameter mm	2-holes 90	4-holes 90 x 40
max. total weight kg	3500	3500
D-value kN ball	10,3	10,3
D-value kN flange	17,2	17,2
vertical load kg ball	100	100
vertical load kg flange	120	120
weight kg	3	3

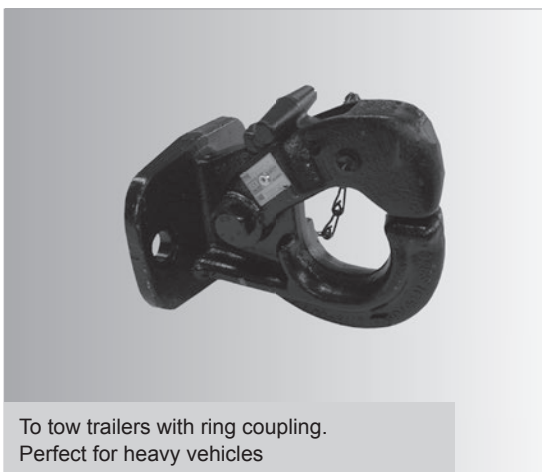

order no.	329 091 600 001
flange plate	114 x 73
hole Ø mm	17
diameter mm	2-holes 90
max. total weight kg	3500
opening mm	50 Ø
D-value kN	27,5
vertical load kg	150
weight kg	3,5



order no.	329 098 600 001	329 094 600 001	329 090 600001
flange plate	122 x 91	122 x 91	122 x 91
hole Ø mm	17	17	11
diameter mm	2-holes 90	4-holes 90 x 40	4-holes 83 x 56
max. total weight kg	3500	3500	3500
D-value kN	24	31	31
vertical load kg	340	340	340
weight kg	5,2	5,2	5,2

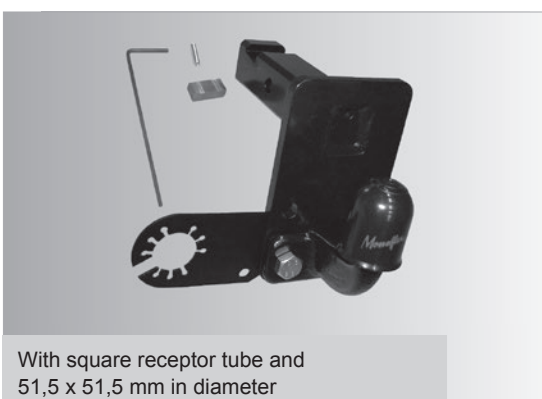

order no.	342 171 600 001	342 192 600 001
set	1 ground plate 1 towball (2-holes) 1 socket holder 1 mounting kit	1 ground plate 1 towball (4-holes) 1 socket holder 1 mounting kit
D/Dc-vlaue	17,17	21,69
weight kg	8	11
vertical load kg	140	140
towing capacity kg	3500	3500

Towbars

Accessories

Spare parts

Accessories



Towball cover blue "Baseball cap"

package 10 pieces **order no.: 300 010 001 909**
package 50 pieces **order no.: 300 050 001 909**



Presentation rack for towbars

(towbars are not included)

order no.: 300 100 600 001



Snap gauge

order no.: 900 001 535 051



Towing bolt

thread M 20 x 1,5

order no.: 900 008 600 001



Towball cover

package 10 pieces **order no.: 917 034 630 010**
package 100 pieces **order no.: 917 034 630 100**



Breakaway Cable Bracket for trailer breakaway cable

fitting for the receptor tube of the following detachable
towbars: 921540627001, 905243627001, 905276627001

order no.: 935 211 627 001

Steps



Step

for Ford Transit van / minibus only in conjunction with Westfalia towbar 30726060001

order no.: 307 267 600 001



Step

for Mercedes-Benz Sprinter and VW LTII -03/06 (van and minibus). Only in conjunction with towbars WAM no.: 313 087/088/103/149/152/154/155 600001

order no.: 313 132 600 001



Step

for Mercedes-Benz Sprinter II and VW LT Crafter 03/06- (van and minibus) Only in conjunction with towbars WAM no.: 313 267/272/273/376 600001

order no.: 313 285 600 001



Step universal

for all universal HGV towbars with 4 hole towballs and universal HGV towbars with 2 hole towballs with a hole spacing of 90 mm e.g. Citroen Jumper, Fiat Ducato, Mercedes Sprinter, Peugeot Boxer, VW Crafter

order no.: 313 440 600 001

Side caps for towing brackets

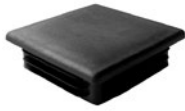

Side cap (2 pcs.) (measurements: 100x100 mm)

342035, 332110, 342076/313146/313192/313193, 313404/342179

order no.: 900 001 503 587



Side cap (2 pcs.) (measurements: 70x50 mm)

30642/151, 306127/208/209, 306210/216, 340070

order no.: 900 001 503 638



Side cap (2 pcs.) (measurements: 95x65 mm)

321322/202/203, 335099/153, 332033/093/340018,
340042/340043, 313222

order no.: 921 201 630 101

Spare parts for detachable towbars



Key for lock automatic towball

(package 2 pcs.) *The last two digits are the numbers that appear on the key head or that you have noted in your manual. Declaration and procedure for ordering keys please find on our website www.westfalia-automotive.com.

order no.: 942 001 513 2xx



Cover for lock automatic towball

(package 10 pieces)

order no.: 905 112 630 101



Skai leather zip bag (for all detachable towbars)

order no.: 900 001 504 923



Bag PVC

(picture similar)

order no.: 921 600 643 101



Metal nut

(incl. 4 steel balls, 1 circlip) # of the ball up to 36 mm

order no.: 903 062 622 101



Metal nut

(incl. 4 steel balls, 1 circlip) # of the ball up to 40 mm

order no.: 914 234 622 101



Ring spanner

for metal nut 36 + 40 mm

order no.: 903 062 622 102

Spare parts for detachable towbars

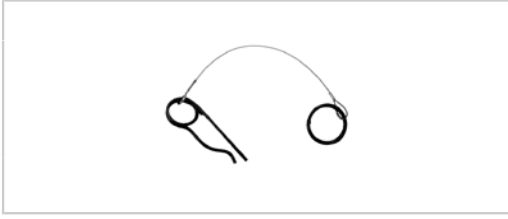

Leg spring

for manual detachable system

order no.: 903 057 626 001

Spare parts for Monoflex-towbars



Rubber boot for knob
for MFII

order no.: 900 001 001 014



Knob
for towbar system MFII

order no.: 900 001 001 017



Socket holder
universal

order no.: 900 001 005 347



Plug cover for front support
for towbar system AHII and AVII from year of construction 2003

order no.: 900 001 005 405



Rear plug cover
for AHII and AVII from year of construction 2003

order no.: 900 001 005 406



Knob incl. lock and key
for towbar system AHII and AVII

order no.: 900 001 005 407



Cotter pin
for Monoflex universal and MFI, detachable systems

order no.: 900 001 005 944

Spare parts for Monoflex-towbars



Plug cover

for towbar system MFII

order no.: 900 001 059 080



Receptor tube incl. clothing/knob

for MFII

order no.: 900 001 059 114



Rear plug cover

for towbar system MFII

order no.: 900 001 059 170

Plug covers for detachable towbars

order no. towbar	order no. plug cover
303078	903 078 630 121
303085	903 078 630 121
303095	903 078 630 121
303124	903 078 630 121
303127	903 078 630 121
303130	903 078 630 121
303140	903 140 630 103
303144	903 078 630 121
303155	903 078 630 121
303170	903 137 630 101
303185	903 140 630 103
303189	903 078 630 121
303202	903 140 630 103
303205	903 078 630 121
303207	903 137 630 101
303228	903 078 630 121
303229	903 078 630 121
303230	903 078 630 121
303231	903 078 630 121
303232	903 078 630 121
303235	903 140 630 103
303240	903 078 630 121
303264	903 078 630 121
303266	903 078 630 121
303273	921 630 630 121
303290	903 137 630 101
303292	921 630 630 121
303294	921 630 630 121
303304	903 078 630 121
303314	921 630 630 121
303317	913 183 630 121
303323	903 078 630 121
303330	903 078 630 121
303336	921 630 630 121
303338	903 078 630 121
303340	921 630 630 121
303352	903 078 630 121
303368	921 630 630 121
303394	921 630 630 121
303398	913 183 630 121
303404	921 630 630 121
304059	903 011 630 108
304060	903 011 630 108
304064	916 114 630 120
304068	913 183 630 121
304072	913 183 630 121
304073	913 183 630 121
304075	913 183 630 121
304076	913 183 630 121
304079	913 183 630 121
304092	913 183 630 121
304100	913 183 630 121

order no. towbar	order no. plug cover
304128	933 034 630 101
304131	913 183 630 121
304137	933 034 630 101
304139	913 183 630 121
304144	913 183 630 121
304145	913 183 630 121
304148	913 183 630 121
304149	913 183 630 121
304152	913 183 630 121
304160	913 183 630 121
305112	905 063 630 103
305131	905 051 630 106
305156	905 063 630 103
305161	905 063 630 103
305164	914 234 630 101
305170	905 063 630 103
305176	905 146 630 101
305191	905 063 630 103
305195	905 063 630 103
305196	905 063 630 103
305197	905 063 630 103
305206	905 146 630 101
305220	905 146 630 101
305223	903 078 630 121
305224	914 234 630 101
305225	903 140 630 103
305243	905 063 630 103
305244	905 063 630 103
305245	905 063 630 103
305246	905 063 630 103
305262	903 078 630 121
305263	905 219 630 103
305269	905 063 630 103
305276	905 219 630 103
305277	903 078 630 121
305291	905 063 630 103
305300	903 078 630 121
305302	905 146 630 101
305309	903 137 630 101
305314	903 137 630 101
305323	913 183 630 121
305350	913 183 630 121
305365	905 368 608 010
305384	921 630 630 121
305398	903 137 630 101
305400	913 183 630 121
305403	921 630 630 121
305405	921 630 630 121
305407	913 183 630 121
305412	913 183 630 121
305413	903 137 630 101

Plug covers for detachable towbars

order no. towbar	order no. plug cover
305415	903 137 630 101
305423	913 183 630 121
305425	905 368 608 010
305429	913 183 630 121
305445	905 368 608 010
306115	903 011 630 108
306128	903 011 630 108
306160	914 234 630 101
306161	903 011 630 108
306166	903 011 630 108
306168	914 234 630 101
306172	914 234 630 101
306174	914 234 630 101
306176	903 011 630 108
306187	903 078 630 121
306189	914 234 630 101
306190	903 011 630 108
306195	903 011 630 108
306197	903 011 630 108
306203	903 011 630 108
306206	903 011 630 108
306211	903 011 630 108
306215	903 078 630 121
306217	914 234 630 101
306218	903 140 630 103
306220	914 234 630 101
306222	903 078 630 121
306224	903 078 630 121
306226	903 011 630 108
306230	903 140 630 103
306231	903 078 630 121
306232	903 011 630 108
306235	903 011 630 108
306237	913 183 630 121
306238	913 183 630 121
306239	913 183 630 121
306240	913 183 630 121
306241	913 183 630 121
306244	903 078 630 121
306245	913 183 630 121
306246	913 183 630 121
306247	913 183 630 121
306249	913 183 630 121
306250	913 183 630 121
306254	913 183 630 121
306262	913 183 630 121
306264	903 011 630 108
306265	903 078 630 121
306266	903 078 630 121
306269	913 183 630 121
306271	903 137 630 101

order no. towbar	order no. plug cover
306275	903 078 630 121
306277	913 183 630 121
306279	913 183 630 121
306286	903 078 630 121
306291	913 183 630 121
306310	916 211 630 121
306311	916 211 630 121
306319	933 034 630 101
306321	913 183 630 121
306322	913 183 630 121
306323	913 183 630 121
306333	933 034 630 101
306350	933 034 630 101
306353	913 183 630 121
306356	921 630 630 121
306361	903 078 630 121
306369	903 078 630 121
306371	903 078 630 121
306372	903 078 630 121
306374	903 078 630 121
306379	933 034 630 101
306381	933 034 630 101
306383	913 183 630 121
306384	913 183 630 121
306389	921 630 630 121
306392	913 183 630 121
306393	913 183 630 121
306394	913 183 630 121
306400	921 630 630 121
307200	903 078 630 121
307210	903 078 630 121
307233	914 234 630 101
307235	903 078 630 121
307237	903 078 630 121
307239	903 078 630 121
307242	903 078 630 121
307245	903 078 630 121
307247	903 078 630 121
307265	913 183 630 121
307269	903 078 630 121
307286	933 034 630 101
307290	933 034 630 101
307291	933 020 630 101
307305	913 183 630 121
307308	913 183 630 121
307329	921 630 630 121
307330	913 183 630 121
307332	921 630 630 121
307333	913 183 630 121
307335	921 630 630 121
307336	921 630 630 121
307338	913 183 630 121

Plug covers for detachable towbars

order no. towbar	order no. plug cover
307340	913 183 630 121
307343	913 183 630 121
307355	913 183 630 121
307356	913 183 630 121
307385	942 097 630 121
307430	900 001 005 405
307441	913 183 630 121
307455	921 630 630 121
307458	913 183 630 121
307461	921 630 630 121
307463	913 183 630 121
307464	921 630 630 121
307474	913 183 630 121
307501	913 183 630 121
313062	903 011 630 108
313073	903 078 630 121
313082	903 078 630 121
313090	903 011 630 108
313097	903 078 630 121
313117	903 011 630 108
313120	903 078 630 121
313129	913 183 630 121
313160	903 078 630 121
313167	903 078 630 121
313174	903 078 630 121
313176	903 078 630 121
313179	903 078 630 121
313183	913 183 630 121
313189	913 183 630 121
313192	903 137 630 101
313195	903 078 630 121
313200	903 078 630 121
313204	903 078 630 121
313211	903 078 630 121
313214	903 078 630 121
313222	903 078 630 121
313231	903 078 630 121
313234	913 183 630 121
313239	903 078 630 121
313241	903 078 630 121
313252	921 630 630 121
313276	903 078 630 121
313340	903 137 630 101
313361	921 630 630 121
313373	913 183 630 121
313382	903 078 630 121
313398	913 183 630 121
313400	913 183 630 121
313406	903 137 630 101
313421	903 137 630 101
313432	913 183 630 121

order no. towbar	order no. plug cover
313436	921 630 630 121
313438	903 078 630 121
313439	903 078 630 121
313506	913 183 630 121
314434	921 630 630 121
314232	914 234 630 101
314234	914 234 630 101
314235	914 234 630 101
314237	914 234 630 101
314239	903 078 630 121
314244	914 234 630 101
314247	903 011 630 108
314251	903 078 630 121
314254	914 234 630 101
314257	903 078 630 121
314259	903 137 630 101
314266	903 078 630 121
314267	903 078 630 121
314270	913 183 630 121
314281	913 183 630 121
314283	903 078 630 121
314287	903 078 630 121
314289	913 183 630 121
314293	913 183 630 121
314295	903 078 630 121
314305	913 183 630 121
314307	903 078 630 121
314309	900 001 005 405
314310	913 183 630 121
314341	913 183 630 121
314342	913 183 630 121
314348	900 001 059 080
314350	921 630 630 121
314351	921 630 630 121
314354	903 078 630 121
314357	921 630 630 121
314372	921 630 630 121
314386	921 630 630 121
314392	921 630 630 121
314406	903 078 630 121
314409	913 183 630 121
314415	921 630 630 121
314416	921 630 630 121
314420	916 114 630 120
314436	903 078 630 121
314437	903 078 630 121
314440	921 630 630 121
314448	903 078 630 121
314451	913 183 630 121
314461	913 183 630 121
314470	921 630 630 121

Plug covers for detachable towbars

order no. towbar	order no. plug cover
314472	903 078 630 121
314473	921 630 630 121
314486	913 183 630 121
314473	921 630 630 121
314500	903 078 630 121
314501	903 078 630 121
314510	913 183 630 121
315039	903 011 630 108
315049	903 011 630 108
315050	903 011 630 108
315055	903 078 630 121
315059	903 011 630 108
315060	903 011 630 108
315062	903 011 630 108
315073	903 011 630 108
315074	903 011 630 108
315076	903 011 630 108
315078	903 011 630 108
315080	914 234 630 101
315084	903 011 630 108
315085	903 011 630 108
315086	903 011 630 108
315087	903 011 630 108
315088	903 078 630 121
315090	913 183 630 121
315092	903 137 630 101
315096	903 078 630 121
315097	903 137 630 101
315098	903 078 630 121
315100	903 011 630 108
315103	903 078 630 121
315105	913 183 630 121
315107	913 183 630 121
315109	903 078 630 121
315111	933 034 630 101
315114	933 034 630 101
315115	933 034 630 101
315119	913 183 630 121
315150	913 183 630 121
315152	913 183 630 121
315158	913 183 630 121
315167	900 001 059 080
315168	900 001 059 080
315171	913 183 630 121
315175	913 183 630 121
315176	900 001 059 080
315178	913 183 630 121
315182	913 183 630 121
315185	913 183 630 121
316190	913 183 630 121
315188	913 183 630 121
316097	903 011 630 108

order no. towbar	order no. plug cover
316100	903 011 630 108
316108	903 011 630 108
316110	914 234 630 101
316112	903 011 630 108
316114	916 114 630 120
316117	916 114 630 120
316119	916 114 630 120
316123	903 011 630 108
316128	903 078 630 121
316137	913 183 630 121
316140	913 183 630 121
316142	913 183 630 121
316143	913 183 630 121
316145	913 183 630 121
316152	913 183 630 121
316156	903 078 630 121
316166	913 183 630 121
316176	913 183 630 121
316177	913 183 630 121
316186	903 078 630 121
316192	903 078 630 121
316194	903 078 630 121
316197	907 286 630 001
316199	907 286 630 001
316207	913 183 630 121
316209	913 183 630 121
316214	916 211 630 121
316217	907 286 630 001
316220	933 034 630 101
316222	933 034 630 101
316225	921 630 630 121
316227	921 630 630 121
316250	916 211 630 121
316252	916 211 630 121
316262	913 183 630 121
316265	913 183 630 121
316267	913 183 630 121
316269	933 034 630 101
316273	913 183 630 121
316278	916 211 630 121
316284	933 034 630 101
316287	933 034 630 101
316291	933 034 630 101
316294	913 183 630 121
316297	913 183 630 121
316307	933 034 630 101
316310	933 034 630 101
316315	913 183 630 121
316320	913 183 630 121
316322	913 183 630 121
316324	913 183 630 121
316325	933 034 630 101

Plug covers for detachable towbars

order no. towbar	order no. plug cover
316326	933 034 630 101
316334	933 034 630 101
316335	933 034 630 101
316337	913 183 630 121
316342	913 183 630 121
316344	933 034 630 101
316355	933 034 630 101
316363	913 183 630 121
316366	913 183 630 121
317016	903 078 630 121
317021	903 011 630 108
317023	903 011 630 108
317035	903 078 630 121
317036	903 078 630 121
317044	903 078 630 121
317046	903 078 630 121
317047	903 078 630 121
317056	903 078 630 121
317058	903 078 630 121
317060	903 078 630 121
317064	921 630 630 121
317066	921 630 630 121
317086	921 630 630 121
317088	903 078 630 121
317102	921 630 630 121
317105	903 078 630 121
317107	921 630 630 121
317117	903 078 630 121
317128	903 078 630 121
317130	921 630 630 121
317132	921 630 630 121
320040	903 078 630 121
320042	903 011 630 108
320044	903 011 630 108
320048	903 078 630 121
320050	913 183 630 121
320053	913 183 630 121
320057	903 078 630 121
320060	903 078 630 121
320064	921 630 630 121
320066	903 078 630 121
320068	913 183 630 121
320070	900 001 005 405
320072	913 183 630 121
320074	900 001 005 405
320075	913 183 630 121
320076	913 183 630 121
320080	913 183 630 121
320085	900 001 005 405
320088	900 001 059 080
320092	900 001 005 405

order no. towbar	order no. plug cover
320097	921 628 630 121
320114	913 183 630 121
320115	921 630 630 121
321330	903 078 630 121
321399	903 011 630 108
321405	903 078 630 121
321407	903 011 630 108
321408	903 011 630 108
321409	903 011 630 108
321423	914 234 630 101
321424	903 078 630 121
321441	903 078 630 121
321453	903 078 630 121
321464	903 078 630 121
321468	903 078 630 121
321505	903 078 630 121
321508	903 078 630 121
321523	903 078 630 121
321525	903 137 630 101
321537	903 078 630 121
321540	903 078 630 121
321543	921 630 630 121
321546	921 546 608 001
321556	903 078 630 121
321605	903 137 630 101
321626	903 011 630 108
321628	921 630 630 121
321630	921 630 630 121
321647	921 630 630 121
321651	921 630 630 121
321659	903 078 630 121
321673	903 078 630 121
321691	913 183 630 121
321700	921 630 630 121
321728	913 183 630 121
321730	921 630 630 121
321736	903 137 630 101
321738	921 630 630 121
321740	921 630 630 121
321748	903 078 630 121
321751	921 630 630 121
321775	903 078 630 121
321778	921 630 630 121
321823	921 630 630 121
321838	903 078 630 121
321852	921 630 630 121
321863	921 630 630 121
321866	921 630 630 121
321869	921 630 630 121
321871	921 630 630 121
321873	921 630 630 121

Plug covers for detachable towbars

order no. towbar	order no. plug cover
321878	921 630 630 121
321885	921 630 630 121
323045	905 146 630 101
323052	905 146 630 101
323062	923 062 630 101
323079	903 078 630 121
323080	903 078 630 121
323084	903 078 630 121
323097	903 078 630 121
323100	903 078 630 121
323102	921 628 630 121
323107	903 137 630 101
323121	903 137 630 101
324012	903 011 630 108
324013	903 011 630 108
324015	914 234 630 101
324019	914 234 630 101
324021	933 020 630 101
324022	933 034 630 101
324028	913 183 630 121
324040	900 001 059 170
327014	905 063 630 103
327068	913 183 630 121
332120	903 011 630 108
332122	903 011 630 108
332124	903 011 630 108
332135	914 234 630 101
332154	903 078 630 121
332176	903 078 630 121
332186	903 078 630 121
332198	903 078 630 121
332206	903 078 630 121
332223	903 078 630 121
332227	903 078 630 121
332232	903 078 630 121
332235	903 078 630 121
332240	933 034 630 101
332241	933 034 630 101
332247	903 078 630 121
332262	933 034 630 101
332265	913 183 630 121
332296	913 183 630 121
332303	913 183 630 121
332304	921 630 630 121
332305	921 630 630 121
332323	913 183 630 121
332327	903 078 630 121
335201	903 011 630 108
335210	903 011 630 108
335216	914 234 630 101
335218	903 011 630 108
335221	903 011 630 108

order no. towbar	order no. plug cover
335225	914 234 630 101
335231	903 011 630 108
335239	913 183 630 121
335240	916 114 630 120
335250	903 137 630 101
335268	913 183 630 121
335281	903 011 630 108
335282	933 020 630 101
335285	913 183 630 121
335289	913 183 630 121
335291	913 183 630 121
335295	913 183 630 121
335302	913 183 630 121
335304	913 183 630 121
335305	913 183 630 121
335323	913 183 630 121
335325	913 183 630 121
335327	933 034 630 101
335344	913 183 630 121
335346	913 183 630 121
335353	913 183 630 121
335355	913 183 630 121
335357	913 183 630 121
335358	913 183 630 121
335360	921 630 630 121
335364	903 078 630 121
335367	903 078 630 121
335372	900 000 059 080
335383	913 183 630 121
335393	903 078 630 121
335398	916 114 630 120
335411	903 078 630 121
335414	913 183 630 121
335419	921 630 630 121
335421	903 078 630 121
335455	913 183 630 121
338038	903 137 630 101
338054	900 001 059 080
338058	907 286 630 001
338059	903 011 630 108
338066	913 183 630 121
338075	900 001 005 405
338081	913 183 630 121
338087	900 001 059 080
338090	933 034 630 101
338092	933 034 630 101
338094	900 001 059 080
338098	913 183 630 121
338104	913 183 630 121
338116	813 183 630 121
338120	913 183 630 121

Plug covers for detachable towbars

order no. towbar	order no. plug cover
340031	903 011 630 108
340037	903 078 630 121
340039	903 078 630 121
340040	905 063 630 103
340052	903 078 630 121
340066	913 183 630 121
340068	933 034 630 101
340072	903 137 630 101
340074	933 034 630 101
340076	900 001 005 405
340081	913 183 630 121
340093	921 630 630 121
340094	921 630 630 121
340095	921 628 630 121
340097	921 630 630 121
341003	903 137 630 101
341004	914 234 630 101
341006	933 034 630 101
341016	933 034 630 101
341018	913 183 630 121
341021	913 183 630 121
342062	903 011 630 108
342068	914 234 630 101
342092	903 078 630 121
342093	903 137 630 101
342097	903 137 630 101
342098	903 137 630 101
342099	903 137 630 101
342103	913 183 630 121
342105	913 183 630 121
342107	933 034 630 101
342113	903 137 630 101
342125	900 001 005 405
342127	916 211 630 121
342129	900 001 005 405
342131	913 183 630 121
342136	916 211 630 121
342138	900 001 059 080 od.:
342138	900 001 059 170
342139	900 001 005 405
342140	900 001 005 405
342151	900 001 059 080
342153	900 001 059 080
342154	900 001 059 080
342155	900 001 059 080
342157	900 001 059 405
342159	900 001 059 080
342163	900 001 059 080
342165	900 001 005 405
342172	900 001 059 080
342177	900 001 005 405

order no. towbar	order no. plug cover
342178	921 630 630 121
342183	913 183 630 121
342185	921 628 630 121
342188	913 183 630 121
342189	913 183 630 121
342197	921 630 630 121
342200	913 183 630 121
342205	813 183 630 121
342207	913 183 630 121
342209	913 183 630 121
342217	921 630 630 121
342221	921 630 630 121
343023	903 011 630 108
343024	903 078 630 121
343037	933 020 630 101
343038	913 183 630 121
343040	913 183 630 121
343043	933 034 630 101
343044	933 034 630 101
343046	913 183 630 121
343047	913 183 630 121
343056	913 183 630 121
343058	913 183 630 121
343061	921 630 630 121
343063	921 630 630 121
343067	913 183 630 121
343074	921 630 630 121
343080	913 183 630 121
344008	903 011 630 108
344024	903 011 630 108
344027	903 011 630 108
344031	903 011 630 108
344039	903 078 630 121
344044	913 183 630 121
344048	913 183 630 121
344050	903 078 630 121
344054	905 146 630 101
344060	921 630 630 121
344074	905 146 630 101
344079	921 630 630 121
345003	903 011 630 108
345016	903 137 630 101
345021	903 078 630 121
345026	933 034 630 101
345028	903 078 630 121
345036	903 078 630 121
345039	903 078 630 121
345055	900 000 059 080
345059	903 078 630 121
345065	913 183 630 121
345068	913 630 630 121

Plug covers for detachable towbars

order no. towbar	order no. plug cover
345070	913 183 630 121
345077	913 183 630 121
345079	913 183 630 121
345080	933 034 630 101
345082	913 183 630 121
345084	913 183 630 121
345086	913 183 630 121
345090	
345096	
346016	903 137 630 101
346019	903 078 630 121
346021	913 183 630 121
346024	933 034 630 101
346026	913 183 630 121
346047	900 001 059 080
346049	913 183 630 121
346051	900 001 059 080
346057	900 001 005 405
346059	900 001 005 405
346060	913 183 630 121
346061	913 183 630 121
346064	913 183 630 121
346066	913 183 630 121
346071	913 183 630 121
346072	913 183 630 121
346074	913 183 630 121
346083	913 183 630 121
346084	913 183 630 121
346087	
348002	903 011 630 108
348003	903 011 630 108
348007	903 011 630 108
348009	903 011 630 108
348012	903 011 630 108
348014	933 020 630 101
348016	913 183 630 121
348018	903 078 630 121
348020	900 001 005 405
348022	913 183 630 121
348024	900 001 005 405
348026	913 183 630 121
348028	913 183 630 121
348031	900 001 005 405
348033	900 001 059 080
348035	913 183 630 121
348037	921 628 630 121
349025	921 630 630 121
349027	921 630 630 121
349039	903 078 630 121

Electrical Kits

Accessories

Spare parts

Universal electrical kits (12 V on-board electrical systems)



Turn signal monitoring by flash unit with C2 function

Universally applicable for vehicles **without** Checkcontrol system, with European 3-pin replacement flash unit with C2 connection with rear fog light shutdown

order no.

300 060 300 107

300 060 300 113

300 061 300 107 (with adapter for deviant flash unit wiring)

300 061 300 113 (with adapter for deviant flash unit wiring)

300 096 300 157 (only wire set for vehicles with C2 feature)

300 096 300 163 (only wire set for vehicles with C2 feature)



Turn signal monitoring by control unit with double flashing rate

Universally applicable for vehicles **without** Checkcontrol system, with rear fog light and acoustic parking system shutdown

order no.

300 052 300 107 (socket with screw contacts, extended socket supplyline, e.g.: for flatbed)

300 052 300 113 (socket with screw contacts, extended socket supplyline, e.g.: for flatbed)

300 072 300 107 (socket with screw contacts)

300 072 300 113 (socket with screw contacts)

300 073 300 113 (flat 40 mm socket with crimp contact and cable inlet on the side)



Turn signal monitoring by control unit with double flashing rate

Universally applicable for vehicles **with** Checkcontrol system, with rear fog light and acoustic parking system shutdown

order no.

300 056 300 107 (socket with screw contacts, extended socket supplyline, e.g.: for flatbed)

300 056 300 113 (socket with screw contacts, extended socket supplyline, e.g.: for flatbed)



Turn signal monitoring by control unit with acoustic error message

Universally applicable for vehicles **with** Checkcontrol system, partially also for vehicles with data bus technology (CAN), with rear fog light and parking system shutdown

order no.

300 210 300 107 (socket with screw contacts)

300 210 300 113 (socket with screw contacts)

Extension kits



Continuous positive and charging line extension kit

Contains the connection for contact 9 and 10 acc. DIN/ISO 11446 incl. fuse and cut-off relay, 12 V

order no.: 300 025 300 113



10p CCM 506 079 (only complete kit)

Signal amplification for Checkcontrol, continuous positive necessary

order no.: 300 025 300 173



Continuous positive extension kit "D1"

(Catalogue identification "D1" in the 16 table column)
Contains the connection for contact 9 (13) acc. DIN/ISO 11446 incl. fuse.

order no.: 300 027 300 113



Charging line extension kit "L1"

(Catalogue identification "L1" in the 17 table column)
Contains the connection for contact 10 and 11 acc. DIN/ISO 11446 incl. fuse and cut-off relay, 12 V

order no.: 300 028 300 113



Rear fog light / Acoustic parking system switch-over kit

Contains a switch-over relay (12V)/ Connection accessories for changing the polarity of the specific function, for example earth-switched rear fog lights on the vehicle.

order no.: 300 065 300 005



Checkcontrol extension kit (for individual Audi models)

Contains the control unit incl. continuous positive connection and fuse, for 6-pin interfaces.

order no.: 305 160 300 173

Control unit 12 V



12p ASTM 12 (former: ALM 12, ASG 2000-121)
Turn signal control, rear fog light shutdown, APS signal (continuous positive necessary)

order no.: 900 001 506 005



12/16p AAG (Audi) 8E0 907 ...
CAN control unit

order no.: 900 001 506 101



22p ASG 2000-222 (replaces ALM 22/2)
Lighting system compl. on the trailer

order no.: 900 001 506 129



8/4/4p Daimler group (A212)
CAN control unit, lighting system compl. trailer

order no.: 900 001 506 156



8/4/4p Daimler group (A169)
CAN control unit, lighting system compl. trailer

order no.: 900 001 506 172



8/4/4p Daimler group (A211)
CAN control unit, lighting system compl. trailer

order no.: 900 001 506 173



30p control unit 506270A
Turn signal control and all light signals (continuous positive necessary), APS signal

order no.: 900 001 506 270

Control unit 12 V



10p ALM10 (former: 58207002)

Turn signal control (continuous positive necessary)

order no.: 900 001 506 274



22p ASG 2000-221 (replaces ALM 22/1)

Lighting system compl. on the trailer

order no.: 900 001 506 434



Control unit ASTM V4 - 30p replaces ASTM pro A1, B1, C1 and 506275

Turn signal control and all light signals (permanent plus necessary), PDC signal, also for dimmed lights

order no.: 900 001 506 499



8p 58 227 001

C2 Turn signal control (continuous positive necessary)

order no.: 900 001 506 540



12p ASTM 10

Turn signal control, rear fog light shutdown, APS signal (no continuous positive necessary)

order no.: 900 001 506 542



12/16p AAG (VW, LED) 1K0 ...

CAN control unit (discontinued model)

order no.: 900 001 506 558



15p (8369019 or 6908767)

Lighting system compl. on the trailer

order no.: 900 001 506 563

Control unit 12 V



18p + 10p (CAN-module 5F001)

Lighting system compl. on the trailer

order no.: 900 001 506 577



18p + 10p (5C028)

Lighting system compl. on the trailer

order no.: 900 001 506 578



12p ASTM R

Turn signal control, rear fog light shutdown, APS signal (no continuous positive necessary)

order no.: 900 001 506 623



Uni CAN Control (BMW UCC1)

CAN control unit, lighting system compl. trailer

order no.: 900 001 506 625



Uni CAN Control (PSA UCC1)

CAN control unit, lighting system compl. trailer

order no.: 900 001 506 626



Uni CAN Control (Ford UCC1)

CAN control unit, lighting system compl. trailer

order no.: 900 001 506 627



Uni CAN Control (Opel UCC1)

CAN control unit, lighting system compl. trailer

order no.: 900 001 506 631

Control unit 12 V



Control unit ASTM LC - 22p

Turn signal control and all light signals (permanent plus necessary), PDC signal, also for dimmed lights

order no.: 900 001 506 633



12/16p AAG (VW Touareg) 7L0 ...

CAN control unit

order no.: 900 001 506 667



Uni CAN Control (Volvo UCC1 (506628) and 3)

CAN control unit, lighting system compl. trailer

order no.: 900 001 506 668



Uni CAN Control (Volvo UCC1 (506632) and 4)

CAN control unit, lighting system compl. trailer

order no.: 900 001 506 669



30p Lancia, 506 691, turn signal control with synchronised fault output

Turn signal control and all light signals (continuous positive necessary), APS signal

order no.: 900 001 506 691



12/14p Opel Astra, Zafira

Lighting system compl. on the trailer

order no.: 900 001 506 907

Relays



Rear fog light switch-off relay

30 = input (rear fog light switch) 87 a = open contact (rear fog light vehicle) 85 = output socket (rear fog light trailer)

order no.: 900 001 506 053



Turn signal (French)

4-pin (506 148) C = 49 a output flash unit + = 49 input flash unit - = 31 earth R = C 1st indicator

order no.: 900 001 506 147



Amplifier up to 25A (changer)

1 = 86 = input control wire 2 = 85 = earth control wire 3 = 30 = input connecting contact 4 = 87a = opener connection contact 5 = 87 = closer connection contact

order no.: 900 001 506 186



Warning blinker switch with C2 function

(VW T4 07/98-)

order no.: 900 001 506 287



Amplifier up to 70A

1 = 86 = input control wire 2 = 85 = earth control wire 3 = 30 = input connecting contact 4 = 87a = opener connection contact 5 = 87 = closer connection contact

order no.: 900 001 506 464



Relay (Mini-model, e.g. Espace, Alfa, Fiat, ... (506 742))

1 = 86 = input control wire 2 = 85 = earth control wire 3 = 30 = input connecting contact 4 = 87a = opener connection contact 5 = 87 = closer connection contact

order no.: 900 001 506 742



Turn signal (European)

3-pin + C2 (506 811) B = 49 input flash unit L = 49 a output flash unit E = 31 earth

order no.: 900 001 506 811

Relays



Turn signal (European) (kit with C2 light and cable)

3-pin + C2 (506 811) B = 49 input flash unit L = 49 a output
flash unit E = 31 earth

order no.: 900 002 506 811

Adapter and plugs



Adapter, short 7/13
from car 7-pins to trailer 13-pins

order no.: 300 100 310 107



Adapter, short 13/7
from car 13-pins to trailer 7-pins

order no.: 300 100 320 113



Plug 13p

order no.: 900 001 506 533



Adapter 13p West
from car 13-pins (DIN/ISO 11446) to trailer 7-/13-pins West

order no.: 900 001 506 997

Sockets and seals



Socket 13-pins

Screw connection (option for cable outlet in the side w. seal 900 001 507 001) cable outlet on side, with rear fog light disconnecting contact

order no.: 900 001 506 001



Socket 13-pins

Contact sockets with solder connections, double microswitch, axial cable outlet

order no.: 900 001 506 037



Socket 7-pins

Screw connection, microswitch changer, axial cable outlet (N-version DIN/ISO 1724)

order no.: 900 001 506 054



Socket 13-pins

Flat version 40 mm high, crimp contact, microswitch, cable outlet on right side

order no.: 900 001 506 124



Socket 13-pins

West plug system Screw connection without rear fog light disconnecting contact, axial cable outlet similar to (N-Version DIN/ISO 1724) + 6 contacts

order no.: 900 001 506 210



Socket 7-pins

Crimp connection, without rear fog light disconnecting contact, axial cable outlet (N-version DIN/ISO 1724)

order no.: 900 001 506 384



Socket 13-pins

Screw connection, microswitch cable outlet on side

order no.: 900 001 506 386

Socket and seals



Socket 13-pins

Screw connection, microswitch axial cable outlet

order no.: 900 001 506 387



Socket 7-pins

Screw connection, rear fog light disconnecting contact, cable outlet on right side (N-version DIN/ISO 1724)

order no.: 900 001 506 397



Socket 7-pins

Screw connection, rear fog light disconnecting contact, axial cable outlet (N-version DIN/ISO 1724)

order no.: 900 001 506 424



Socket 13-pins

Screw connection (option for cable outlet in the side w. seal 900 001 507 001) axial cable outlet, without rear fog light disconnecting contact

order no.: 900 001 506 439



Socket 7-pins

7p. Extension socket for English vehicle market (S-version DIN/ISO 3732)

order no.: 900 001 506 656



Socket 13-pins

Screw connection (option for cable outlet in the side w. seal 900 001 507 001) axial cable outlet, with rear fog light disconnecting contact

order no.: 900 001 506 680

Accessories for sockets



Screw connection with bellows, cable outlet on right side

package 10 pieces: order no. 900 010 503 924

order no.: 900 001 503 924



Socket seal, 2 axial cable outlets

order no.: 900 001 506 010



Socket seal with bellows, axial cable outlet

package 10 pieces: order no. 900 010 506 024

order no.: 900 001 506 024



Substitute socket housing 52 mm high, axial cable outlet

order no.: 900 001 506 438



Seal for 900 001 506 439/680/001/, outlet on right side, 2 pieces

package 10 pieces: order no. 900 010 507 001

order no.: 900 001 507 001



Additional socket plate for 2nd socket

(GB market)

order no.: 900 001 535 208



Cable support sleeve angled, for 40 mm car body openings, cable diameter: 6 - 14 mm

(package 10 pieces)

order no.: 900 010 303 015

Accessories for sockets



Socket seal, axial cable outlet

(package 10 pieces)

order no.: 900 010 506 531



Socket base plate for slit holders

(package 10 pieces)

order no.: 900 010 506 616



Spare part kit folding plastic socket holder

with slot

order no.: 907 292 608 001



Substitute socket holder, universal

package 10 pieces: order no. 920 036 608 110

order no.: 920 036 608 001



Spare part kit folding plastic socket holder

without slot

order no.: 921 504 608 001

Accessories



Vehicle tester trailer simulation 12 V, for function control and fault simulation

order no.: 900 001 300 198



Signal generator

6 - 24 Volt

order no.: 900 001 300 200



Cable connector for cable diameter 0.35-0.75 m²

(package 4 pieces)

order no.: 900 001 506 102



C2 light compl. 12 V (short version)

long version: order no. 900 001 507 809

order no.: 900 001 506 547



Charger / Voltage stability device Bosch (BAT 415)

Used for stabilising the voltage even without vehicle battery. Loading with connected battery, battery support during test mode.

order no.: 900 001 506 599



Cable connector

for cable diameter 1.0-2.5 m²

order no.: 900 010 507 391



Relay adapter

(for adapting various different relay assignments)

order no.: 900 061 305 001

Accessories



C2 cable bridge for older Vauxhall vehicles

order no.: 914 083 303 020

Cycle carrier BC 60

Accessories
Spare parts

Load Carrier System BC 60



Bicycle carrier BC 60

Measurements (W/H/D): 580 x 225 x 690 mm (hinged) / 1260 x 660 x 690 mm (expanded) Weight: 17,5 kg Max. payload: 60,0 kg Wheelbase: up to 1300 mm Bicycle frame: up to 80 mm diameter Section width: up to 60 mm

order no.: 350 030 600 001



Expansion rail for the 3rd bicycle (20 kg payload)

(for models Portilo (year of construction: -12/2011: order no. 350 001 600 001))

order no.: 350 014 600 001



Box

Measurements (W/H/D): 1170 x 600 x 425 mm Weight: 15,0 kg Max. payload: 45,0 kg Capacity: 200 l Colour: anthracite

order no.: 350 002 600 001



Platform

Measurements (W/H/D): 1290 x 230 x 413 mm Weight: 6,0 kg Max. payload: 54,0 kg Colour: anthracite

order no.: 350 004 600 001



Bag

For clean stowage of the Portilo cycle carrier

order no.: 350 008 600 001



Drive up ramp (for easy loading of heavy cycles)

(for models Portilo (year of construction: -12/2011: order no. 350 009 600 001))

order no.: 350 020 600 001



Wall mounting bracket

Steel construction for easy storage of the BC 60 cycles carrier to any wall

order no.: 350 006 600 001

Load Carrier System BC 60



Additional brake light

Legal requirement if the bikes obscure the 3rd brake light of the vehicle

order no.: 350 000 305 173



Presentation rack cycle carrier

(cycle carrier is not included)

order no.: 950 003 631 001

Load Carrier Spare Parts



Light cluster left (without cable)

order no.: 950 000 302 003



Light cluster right (without cable)

order no.: 950 000 302 004



Rubber for gripping lever

order no.: 950 000 503 001



Bracket / bow

order no.: 950 000 613 001



Receiver for bracket + 2x cog wheel

order no.: 950 000 621 001



Gear belt extension

order no.: 950 000 622 002



Light cluster arm left

order no.: 950 000 631 001

Load Carrier Spare Parts



Light cluster arm right

order no.: 950 000 631 002



Light traverse middle

order no.: 950 000 631 003



Bracket for licence plate
(EU-standard size)

order no.: 950 000 631 004



Claw short incl. key / lock

order no.: 950 000 633 001



Claw long incl. key / lock

order no.: 950 000 633 002



knob for claw (2 pieces)

Key for knob (2 pieces): order no. 950 000 513 3xx (xx = number of the key)

order no.: 950 000 633 003



Star grip incl. round head screw

order no.: 950 000 637 001

Load Carrier Spare Parts



Claw for 3rd bicycle incl. key / lock

order no.: 950 001 633 004



Wing (left)

(for models Portilo (year of construction: -12/2011: order no. 950 000 619 001))

order no.: 950 010 619 002



Wing (right)

(for models Portilo (year of construction: -12/2011: order no. 950 000 619 001))

order no.: 950 010 619 003



Gear belt incl. Clothing (ratchet belt)

(for models Portilo (year of construction: -12/2011: order no. 950 000 622 001))

order no.: 950 010 622 001



Locking mechanism for wings (4 pieces)

order no.: 950 010 627 001

Power Springs

Product Range Power Springs

Manufacturer	Model	Remarks	Year of manufacture	Item number	
Audi	A3		04/12-	405403500001	
Audi	A3 Sportback	exc. vehicles with level control, exc. 4 WD	06/03-	421600500001	
Audi	A3 Sportback		09/12-	405403500001	
Audi	A4		11/07-	405425500001	
Audi	A4 Avant		11/07-	405425500001	
Audi	A5		06/11-	405425500001	
Audi	A6		05/04-03/11	405269500001	
Audi	A6		04/11-	405425500001	
Audi	A6 Avant		03/05-08/11	405269500001	
Audi	A6 Avant		09/11-	405425500001	
Audi	Q5		11/08-	405425500001	
Audi	S3		09/13-	405403500001	
Citroën	Berlingo	SWB, exc. Multispace; L1 exc. Tepee alternate spring*	04/08-	404092500001	
Citroën	Berlingo	LWB, L2 alternate spring*	04/08-	404131500001	
Citroën	C4 Picasso	only for vehicles with 5 seats exc. height control alternate spring*	03/07-	404092500001	
Citroën	Jumper	30, 33, 35 / 3t, 3,3t, 3,5t	06/06-	404271500001	
Citroën	Jumpy	not for level control	01/07-	404333500001	
Citroën	Nemo	alternate spring*	02/08-	406350500001	
Fiat	Doblo I		12/01-01/10	406279500001	
Fiat	Doblo II	exc. Cargo	02/10-	406369500001	
Fiat	Doblo II	Cargo	02/10-	406368500001	
Fiat	Ducato	30, 33, 35 / 3t, 3,3t, 3,5t	06/06-	404271500001	
Fiat	Fiorino	alternate spring*	02/08-	406350500001	
Fiat	Scudo	not for level control	01/07-	404333500001	
Ford	C-Max		12/10-	407441500001	
Ford	Focus C-max		10/03-10/10	407458500001	
Ford	Focus II		11/04-01/11	407458500001	
Ford	Focus III		04/11-	407441500001	
Ford	Focus Wagon II	alternate spring*	11/04-07/10	407407500001	
Ford	Focus Wagon III	alternate spring*	05/11-	407456500001	
Ford	Mondeo	alternate spring*	03/07-	420064500001	
Ford	Mondeo Wagon	alternate spring*	03/07-01/11	420064500001	
Ford	S-Max	alternate spring*	05/06-	407405500001	
Ford	Tourneo Connect	SWB and LWB	12/02-	407262500001	
Ford	Transit	not for chassis cab	01/00-	407385500001	
Ford	Transit Connect	SWB and LWB	12/02-	407262500001	
Hyundai	H300 / H1	only for 4 x leaf spring package	01/08-	446047500001	
Hyundai	H300 / H1	not for level control	01/08-	446056500001	
Mazda	3		10/03-12/09	407458500001	

Manufacturer	Model	Remarks	Year of manufacture	Item number	
Mazda	5		05/05-09/10	407458500001	
Mazda	5		09/10-	407458500001	
Mercedes-Benz	Citan	exc. 4WD	11/12-	413432500001	
Mercedes-Benz	Sprinter / Chassis	ex. twin tyres	06/06-	413376500001	
Mercedes-Benz	Vito		10/03-	413382500001	
Nissan	NV 200		11/09-	432265500001	
Nissan	NV 400	front wheel drive	11/11-	416318500001	
Opel	Astra		12/09-	414406500001	
Opel	Astra Sports tourer		10/10-	414406500001	
Opel	Combo	exc. Cargo	02/10-	406369500001	
Opel	Combo	Cargo	02/10-	406368500001	
Opel	Insignia		07/08-	414341500001	
Opel	Insignia Sports Tourer		07/08-	414341500001	
Opel	Movano	front wheel drive	11/11-	416318500001	
Opel	Vectra Caravan		10/03-	414295500001	
Opel	Vivaro	max. 1650 kg axle load	10/01-	414364500001	
Peugeot	Bipper	alternate spring*	02/08-	406350500001	
Peugeot	Boxer	30, 33, 35 / 3t, 3,3t, 3,5t	06/06-	404271500001	
Peugeot	Expert	not for level control	01/07-	404333500001	
Peugeot	Partner	SWB, exc. Multispace; L1 exc. Tepee alternate spring*	04/08-	404092500001	
Peugeot	Partner	LWB, L2 alternate spring*	04/08-	404131500001	
Renault	Kangoo Express	ex. 4WD	11/07-	416269500001	
Renault	Master	front wheel drive	11/11-	416318500001	
Renault	Traffic	max. 1650 kg axle load	10/01-	414364500001	
Seat	Alhambra		10/10-	421600500001	
Seat	Altea	exc. vehicles with level control, exc. 4 WD	06/04-	421600500001	
Seat	Altea XL	exc. vehicles with level control, exc. 4 WD	11/06-	421600500001	
Seat	Leon	exc. vehicles with level control, exc. 4 WD	09/05-	421600500001	
Seat	Leon		01/13-	405403500001	
Seat	Leon ST		11/13-	405403500001	
Seat	Toledo	exc. vehicles with level control, exc. 4 WD	11/04-06/09	421600500001	
Škoda	Octavia	inc. 4WD, exc. vehicles with level control	09/04-12/08	421600500001	
Škoda	Octavia	inc. 4WD, exc. vehicles with level control	01/09-11/12	421600500001	
Škoda	Octavia		11/12-	405403500001	
Škoda	Octavia Combi		11/12-	405403500001	
Škoda	Octavia Kombi	inc. 4WD, exc. vehicles with level control	02/05-12/08	421600500001	
Škoda	Octavia Kombi	inc. 4WD, exc. vehicles with level control	01/09-	421600500001	
Škoda	Octavia Scout		07/09-	421600500001	
Škoda	Superb		09/08-	421600500001	
Škoda	Superb Kombi		01/10-	421600500001	

Manufacturer	Model	Remarks	Year of manufacture	Item number	
Škoda	Yeti	not for level control	09/09-	421600500001	
Volkswagen	Caddy (4-Motion, Maxi)		03/05-10/10	421673500001	
Volkswagen	Caravelle		10/10-	421391500001	
Volkswagen	Crafter / Chassis	ex. twin tyres	08/10-	413376500001	
Volkswagen	Eos		10/08-	421600500001	
Volkswagen	Golf V	exc. vehicles with level control, exc. 4 WD	07/90-04/03	421600500001	
Volkswagen	Golf V Plus	exc. vehicles with level control, exc. 4 WD	06/06-	421600500001	
Volkswagen	Golf V Variant	exc. vehicles with level control, exc. 4 WD	04/06-	421600500001	
Volkswagen	Golf Variant		03/07-	405403500001	
Volkswagen	Golf VI		11/03-11/08	421600500001	
Volkswagen	Golf VI Plus		02/05-04/09	421600500001	
Volkswagen	Golf VI Variant		05/07-	421600500001	
Volkswagen	Golf VII		04/03-	405403500001	
Volkswagen	Jetta V		07/13-	421600500001	
Volkswagen	Jetta VI	exc. Bluemotion	10/08-	421600500001	
Volkswagen	Passat B5	inc. Variant and Bluemotion/exc. Vehicles with level control and 4WD	04/09-	421600500001	
Volkswagen	Passat B6	exc. Bluemotion / inc. 4-Motion	09/09-	421600500001	
Volkswagen	Sharan		11/12-	421600500001	
Volkswagen	Tiguan	inc. 4WD / exc. vehicles with electronic brake force distribution	09/05-	421600500001	
Volkswagen	Touran	exc. vehicles with level control, exc. 4 WD	01/11-	421600500001	
Volkswagen	Transporter T3		05/79-12/92	421391500001	
Volkswagen	Transporter T4		07/90-04/03	421391500001	
Volkswagen	Transporter T5		05/03-	421651500001	
Volvo	S40 I		07/04-	407458500001	
Volvo	V40		03/12-	407441500001	
Volvo	V50		08/04-	407458500001	
Volvo	V70 III	alternate spring*	08/07-	407405500001	
Volvo	XC60	alternate spring*	05/08-	420064500001	

*With these vehicles the power spring replaces the existing spring.

Roof Racks

Product Range Roof Racks

Manufacturer	Model	Version	Year of manufacture	Item number	
Citroën	Berlingo	L1	07/08-	504091700001	
Citroën	Grand Berlingo	L2	07/08-	504129700001	
Citroën	Jumper	L1H1	06/06-	506330700001	
Citroën	Jumper	L2H1/L2H2	06/06-	506357700001	
Citroën	Jumper	L3H2	06/06-	506271700001	
Citroën	Jumper	L4H2	06/06-	506329700001	
Citroën	Jumpy	L1H1 double doors	03/07-	506331700001	
Citroën	Jumpy	L1H1 tailgate	03/07-	506333700001	
Citroën	Jumpy	L2H1 double doors	03/07-	506332700001	
Citroën	Jumpy	L2H1 tailgate	03/07-	506364700001	
Citroën	Nemo	double doors	02/08-	506349700001	
Citroën	Nemo	tailgate	02/08-	506350700001	
Dacia	Dokker	double doors		516333700001	
Fiat	Ducato	L1H1	06/06-	506330700001	
Fiat	Ducato	L2H1/L2H2	06/06-	506357700001	
Fiat	Ducato	L3H2	06/06-	506271700001	
Fiat	Ducato	L4H2	06/06-	506329700001	
Fiat	Fiorino	double doors	02/08-	506349700001	
Fiat	Fiorino	tailgate	02/08-	506350700001	
Fiat	Scudo	L1H1 double doors	03/07-	506331700001	
Fiat	Scudo	L1H1 tailgate	03/07-	506333700001	
Fiat	Scudo	L2H1 double doors	03/07-	506332700001	
Fiat	Scudo	L2H1 tailgate	03/07-	506364700001	
Ford	Transit	L1H1	01/06-	507260700001	
Ford	Transit	L1H2/L2H2	01/06-	507378700001	
Ford	Transit	L2H1	01/06-	507258700001	
Ford	Transit	L3H2	01/06-	507284700001	
Iveco	Daily	L1H1	05/99-	542168700001	
Iveco	Daily	L1H2	05/99-	542176700001	
Iveco	Daily	L2H2	05/99-	542176700001	
Iveco	Daily	L2H2	05/99-	542177700001	
Iveco	Daily	L3H2	05/99-	542087700001	
Iveco	Daily	L4H2	05/99-	542088700001	
Mercedes	Citan	L2	10/12-	516268700001	
Mercedes	Citan Compact	L1	10/12-	513353700001	
Mercedes	Citan Maxi	L3	10/12-	516269700001	

Manufacturer	Model	Version	Year of manufacture	Item number	
Mercedes	Sprinter	L1H1 Please order separatly at the Mercedes dealer: Slide rail B66560751	06/06-	513376700001	
Mercedes	Sprinter	L2H1 Please order separatly at the Mercedes dealer: Slide rail B66560752	06/06-	513272700001	
Mercedes	Sprinter	L2H2 Please order separatly at the Mercedes dealer: Slide rail B66560752	06/06-	513273700001	
Mercedes	Sprinter	L3H2 Please order separatly at the Mercedes dealer: Slide rail B66560753	06/06-	513268700001	
Mercedes	Sprinter	L4H2 Please order separatly at the Mercedes dealer: Slide rail B66560754	06/06-	513267700001	
Mercedes	Vito Compact	L1 double doors	09/03-	513175700001	
Mercedes	Vito Compact	L1 tailgate	09/03-	513240700001	
Mercedes	Vito ExtraLong	L3 double doors	09/03-	513176700001	
Mercedes	Vito ExtraLong	L3 tailgate	09/03-	513381700001	
Mercedes	Vito Long	L2 double doors	09/03-	513382700001	
Mercedes	Vito Long	L2 tailgate	09/03-	513239700001	
Nissan	NV200	double doors	11/09-	532264700001	
Nissan	NV200	tailgate	11/09-	532265700001	
Nissan	NV400	L1H1/L2H2	02/10-	516318700001	
Nissan	NV400	L2H2	02/10-	516327700001	
Nissan	NV400	L3H2	02/10-	516328700001	
Nissan	NV400	L4H2	02/10-	516329700001	
Opel	Movano II	L1H1/L2H2	02/10-	516318700001	
Opel	Movano II	L2H2	02/10-	516327700001	
Opel	Movano II	L3H2	02/10-	516328700001	
Opel	Movano II	L4H2	02/10-	516329700001	
Peugeot	Bipper	double doors	02/08-	506349700001	
Peugeot	Bipper	tailgate	02/08-	506350700001	
Peugeot	Boxer	L1H1	06/06-	506330700001	
Peugeot	Boxer	L2H1/L2H2	06/06-	506357700001	
Peugeot	Boxer	L3H2	06/06-	506271700001	
Peugeot	Boxer	L4H2	06/06-	506329700001	
Peugeot	Expert	L1H1 double doors	03/07-	506331700001	
Peugeot	Expert	L1H1 tailgate	03/07-	506333700001	
Peugeot	Expert	L2H1 double doors	03/07-	506332700001	
Peugeot	Expert	L2H1 tailgate	03/07-	506364700001	

Manufacturer	Model	Version	Year of manufacture	Item number	
Peugeot	Grand Partner	L2	07/08-	504129700001	
Peugeot	Partner	L1	07/08-	504091700001	
Renault	Kangoo	L1	02/08-	513353700001	
Renault	Kangoo	L2	02/08-	516268700001	
Renault	Kangoo	L3	02/08-	516269700001	
Renault	Master	L1H1/L2H2	02/10-	516318700001	
Renault	Master	L2H2	02/10-	516327700001	
Renault	Master	L3H2	02/10-	516328700001	
Renault	Master	L4H2	02/10-	516329700001	
Toyota	ProAce	L1H1 double doors	08/13-	506331700001	
Toyota	ProAce	L1H1 tailgate	08/13-	506333700001	
Toyota	ProAce	L2H1 double doors	08/13-	506332700001	
Toyota	ProAce	L2H1 tailgate	08/13-	506364700001	
Volkswagen	Caddy III	L1 without roof railing	01/04-	521660700001	
Volkswagen	Caddy III	L2 without roof railing	01/04-	521661700001	
Volkswagen	Crafter	L1H1 Please order separatly at the VW dealer: Slide rail 2E1860181, end cover 2E1867279A, 6 pcs. nut N90733701	06/06-	513376700001	
Volkswagen	Crafter	L2H1 Please order separatly at the VW dealer: Slide rail 2E1860181, 2E1860183, 8pcs.nut N90733702	06/06-	513272700001	
Volkswagen		L2H2 Please order separatly at the VW dealer: Slide rail 2E1860181, 2E1860183, 8pcs.nut N90733704	06/06-	513273700001	
Volkswagen	Crafter	L3H2 Please order separatly at the VW dealer: Slide rail 2E1860181, 2E1860182, 11pcs.nut N90733705	06/06-	513268700001	
Volkswagen	Crafter	L4H2 Please order separatly at the VW dealer: Slide rail 2E1860181, 2E1860184, 12pcs.nut N90733705	06/06-	513267700001	
Volkswagen	T5	L1	05/03-	521650700001	
Volkswagen	T5	L2	05/03-	521651700001	

Visit us
on the Internet

westfalia-automotive.com



Certified supplier to the automotive industry

Westfalia-Automotive GmbH
Am Sandberg 45
33378 Rheda-Wiedenbrück
Telephone: +49 5242 907 0
Fax: +49 5242 907 195
westfalia-automotive.com

Errors and omissions excepted.
Issue 02/2015 - 891510

